



Volume 113

2021

p-ISSN: 0209-3324

e-ISSN: 2450-1549

DOI: <https://doi.org/10.20858/sjsutst.2021.113.17>



Journal homepage: <http://sjsutst.polsl.pl>

---

**Article citation information:**

Wheatley, G., Ali, A. Shifter mechanism design for FSAE motor sports vehicle JCU.  
*Scientific Journal of Silesian University of Technology. Series Transport.* 2021, **113**, 219-229.  
ISSN: 0209-3324. DOI: <https://doi.org/10.20858/sjsutst.2021.113.17>.

**Greg WHEATLEY<sup>1</sup>, Ahmed ALI<sup>2</sup>**

## **SHIFTER MECHANISM DESIGN FOR FSAE MOTOR SPORTS VEHICLE JCU**

**Summary.** This report provides a design analysis of a replacement's shifter mechanism for the 2014 model JCU Motorsports FSAE vehicle. Common FSAE shifter mechanisms were researched and reviewed to provide a better understanding of the needs required. A design approach was constructed to ultimately design a mechanism that conformed to all existing constraints and FSAE rules. Realistic load cases were identified and employed in the FEA analysis of the design. Supporting hand calculations were developed, proving the analysis to be accurate. Results showed the shifter mechanism does not fail under infinite life, with some parts of the design having a reasonably high safety factor, ensuring stability.

**Keywords:** mechanical shifter, solid linkage, spline attachments, FEA

### **1. BACKGROUND AND LITERATURE REVIEW**

This work focuses on designing a replacement shifter mechanism for the 2014 model JCU Motorsports FSAE car. The current shifter mechanism uses a cable linkage method where the gear shifter is located on the right-hand side of the driver. The second-generation design will include repositioning of the shifter to the left-hand side of the vehicle.

---

<sup>1</sup> College of Science & Engineering, James Cook University, Townsville, Australia.  
Email: [greg.wheatley@jcu.edu.au](mailto:greg.wheatley@jcu.edu.au). ORCID: <https://orcid.org/0000-0002-9115-9695>

<sup>2</sup> College of Engineering, King Saud University, Riyadh, Saudi Arabia. Email: [jubara66@hotmail.com](mailto:jubara66@hotmail.com).  
ORCID: <https://orcid.org/0000-0001-7490-4545>

In the shifter mechanism selection process, several distinctively different methods were considered; these methods include cable, electronic, solid and pneumatic forms of shifter linkage. These methods were investigated to demonstrate their advantages and disadvantages to determine the most effective design following JCU Motorsports and FSAE regulations.

### 1.1. Pneumatic gear shifter

Pneumatic shifters use compressed air to convey a shift in gear from the clutch near the driver to the engine of the vehicle. The motion required to shift the gears of the engine is a simple bi-directional linear throw. The compressed air canisters required for a pneumatic system weigh 4-6 kg. The FSAE team has ambitious weight-saving targets for this season and is not interested in adding excessive weight for a new shifting mechanism.

### 1.2. Electric solenoid shifter

This type allows the driver to perform a quick and accurate gear selection. The system is maneuverable for any gear shifter location, as it only requires the base or Tiptronic server and solenoid. The shift times can be greatly increased, and two hands can still be on the steering wheel during shifting. This is one of the most promising types with all the fancy advantages.

The main drawback of this method is that it is very heavy and larger than was earlier anticipated. Weight and packaging space are serious concerns with the Formula car. In addition, the system could not be used for extended periods of time without draining the battery. Therefore, this option was eliminated.

### 1.3. Solid linkage shifter

It operates based on the push and pull action of the lever. The cost of this type is very effective. Besides, when it comes to adjusting and fixing, it is quite easy since the system is purely mechanical. It is known that the weight of the solid linkage is quite light compared to the others and that makes a critical change in the different adjustments of the vehicle speed. Another significant thing worth mentioning is the true feeling it gives when it comes to mechanic shifting.

### 1.4. Summary

The criteria for comparison used to select the concept method includes budget, reliability, maintainability, and performance. It was advised to use solid linkage shifters due to their reliability and cost. A summary of the shifter linkage method is outlined in Tab. 1.

Tab. 1.

Shifter linkage method

Method	Advantages	Disadvantages
Cable (current design)	Cost effective. Versatile positioning. Easily adjustable.	Lubrication. Regular maintenance and adjustment. Sloppiness. Less maneuverability.

		No much 'feel' when shifting (struggle finding neutral).
Pneumatic solenoid shifter	Very responsive. Maneuverable mounting positions.	Expensive. Heavy (requires compressed air unit).
Electronic solenoid shifter	Quick and accurate shifting. Maneuverable. Both hands on the steering wheel.	Expensive. Heavy (requires power source). Hard to tune.
Solid linkage shifter	Costly effective. Reliable and responsive. No additional lubrication. Easily adjustable. Better 'feel' when shifting.	Fixed positioning. Requires a straight line between gearbox and shifter. Requires dual action linkage. Shift time is not improved.

## 2. DESIGN APPROACH

### 2.1. Constraints

The approach to designing and installing a solid linkage shifter mechanism on the new generation vehicle meant that several components impose restrictions on the design, particularly geometrically.

**Chassis geometry:** the new generation chassis members have been designed in such a way that the lower members are not parallel to the floor. These members incur a 5 degrees bend at a position close to the fuel tank. Thus, the design of a solid linkage will be restricted to having a non-horizontal linkage mid-section and will need to be manipulated specifically to frame constraints.

**Shifter position:** it is required that all components of the shifter mechanism be located inside the chassis of the vehicle. Due to the gear shifter being positioned on the left-hand side of the vehicle, it is important that the driver can easily operate the shifter, and that no components interfere with the driver's position or ability to enter or exit the vehicle as per FSAE regulations.

**Gearbox position:** due to the positioning of the engine in the frame, the gearshift shaft remains in a fixed location with the only option for modification being an extension section to the splined gear shaft. The shifter mechanism would not warrant engine repositioning.

### 2.2. Loads

To satisfy the geometric constraints for the solid linkage and shifter mounting position, an initial geometric analysis was performed using Solidworks and a 3D model of the 2014 model frame. Due to the nature of the solid linkage being of fixed length, the geometric analysis of the 2014 model frame was imperative to produce an arrangement to fit as required and perform responsively. As part of this design phase, the decision to create a mechanism with an adjustable mounting position was made to ensure a successful positioning and adjustment.

The specific load cases were produced using data generated from the hand strength of males. According to the data in [5], with the driver being in  $2/3 \pi$  elbow flexion, the peak force generated was 151 N pulling and 116 N pushing with the left hand. However, this is the peak force capable and a force considerably less will be commonly employed. It is assumed that

approximately 70% of the peak force will be used, and therefore, the revised load case on the shifter is 105.7 N pulling and 81.2 N pushing.

From inspection of the track, it is approximated that 60 shifts will occur for each lap. Further, it is assumed a maximum of 12 laps will occur each year. Over a three years period, an estimated 30,000 gear changes will occur.

### 2.3. Material selection

The material selection process used to determine the most suitable material for the shifter mechanism is based on several critical criteria and a point-scoring system. The performance criteria selected include cost, weight, supply, strength, and fabrication. Those parameters have been weighted (out of 5 points) according to their influence on the design criteria.

Due to budget constraints, the cost was given an X3 rating. Besides, weight and strength received an X2 weighting. The material selection process described below was used for each individual component of the shifter mechanism assembly (Table 2). While the others were weighted by X1.

Tab. 2.

Material selection

Material	Cost ×3	Weight ×2	Accessibility ×1	Strength ×2	Fabrication ×1	Score
Steel	5	2	5	4	5	21
Titanium	1	5	1	5	2	14
Aluminum	4	4	4	3	3	18
Carbon Fiber	1	5	2	3	1	12

Steel was selected as the most suitable material. Hence, several different steel types were analyzed similarly to determine the type used for each component of the mechanism (Table 3).

Tab. 3.

Type of steel selection

Steel Type	Cost ×3	Weight ×2	Accessibility ×1	Strength ×2	Fabrication ×1	Score
Carbon	4	3	5	3	5	20
Stainless	2	3	4	3	3	15
Mild	4	3	5	2	5	19
Alloy	1	4	2	5	1	13

Carbon steel is the most viable option to produce the design geometry based on the criteria specified above. Therefore, the AISI 1040 Steel was chosen due to its workability and the carbon fiber was selected for the shifter mechanisms manufactured parts except for the shifter grip. The AISI 1040 Steel has ultimate and yield strengths of 586 MPa and 430 MPa, respectively.

### 3. FINITE ELEMENT ANALYSIS

To simplify the modeling of the shifter mechanism, the shifter, linkage, and spline attachment were analyzed individually. The initial load case was applied to the shifter and once the output force was found, the consecutive parts were modeled by the same process.

Various mesh parameters were analyzed to ensure an accurate solution. Initially, a fine mesh was used to identify the critical zones of the part being analyzed. Once a solution was found, to increase accuracy, mesh refinements were applied to get converged results.

The fatigue strength factor was calculated using the endurance limit factors. Geometric and loading case factors were calculated by ANSYS, and consequently, only temperature factor, surface factor, and reliability factor need to be determined. The reliability factor was taken at 99% reliability, temperature was assumed to be less than 300°C. The determined endurance factors can be seen in Tab. 4.

Tab. 4.

Endurance modifying factors

Surface factor	Temperature factor	Reliability factor	Endurance limit factor
Cs	Ct	Cr	Kt
0.77	1	0.814	0.63

#### 3.1. Mechanical shifter

The shifter mechanism is modeled as the worst cases scenario, where the shifter may be jammed in the neutral position or it may be difficult to change gears. The load case is applied to the top surface of the shifter to account for the worst-case scenario, where the driver shifts from the top of the handle rather than using the grip. The contact between the handle and the shifter lever was set to “no separation”, and to accurately model the bolts holding the handle in position, a joint load was applied to the inside surfaces of the bolt holes. These two mechanisms prevent movement of the handle in all directions and allow accurate modeling of the shifter. Analysis of the bolts was confirmed via hand calculations. Fig. 1 shows the equivalent stress distribution.

The output force at the fixed support was 190 N. As stated, this force will be considered as the load case for the solid linkage.

#### 3.2. Solid linkage

The solid linkage was modeled using a fixed support at one end and a frictionless support over the middle surface and a remote force, acting along the length of the solid linkage on the other end. The frictionless support acts as the rubber boot, which is placed through the firewall of the FSAE car. The load case was determined from the previous shifter analysis.

As seen in Fig. 2, the maximum stress occurring in the solid linkage is 8.75 MPa, which is significantly less than the previous part.

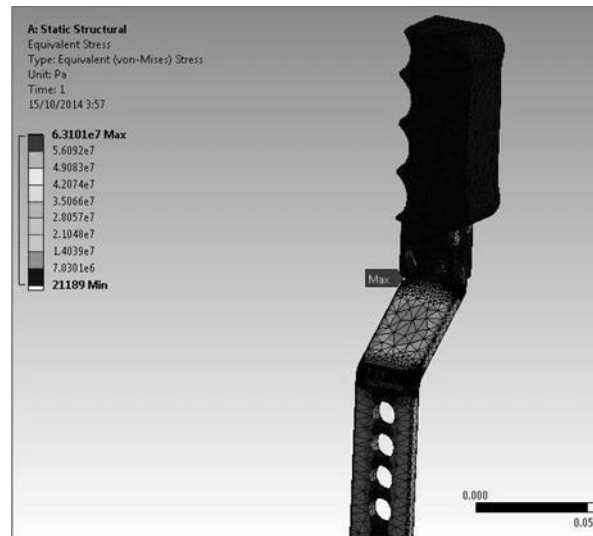

Fig. 1. Equivalent stress results of the shifter

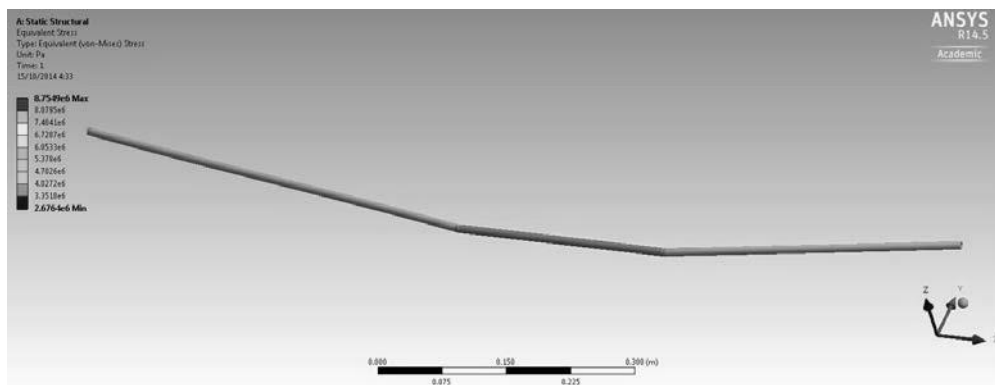

Fig. 2. Equivalent stress results of the solid linkage

The maximum stress occurs at the manipulated bend in the CHS, which is expected, as this is where the stress concentration occurs. Due to a low maximum stress, under fatigue loading, the solid linkage has a minimum safety factor of 7.899. The outer diameter of the solid linkage design is shown to be considerably larger than needed; however, the size of the diameter is essential as it reduces the amount of flexibility in the solid linkage. The stability is demonstrated by the total deformation value of 0.036 mm, which is occurring due to the high safety factor. The reaction force on the fixed support was calculated to be 191.17 N, which will be used as the load cases in the analysis of the spline attachment.

### 3.3. Spline attachments

The gear lever was modeled using a fixed support at the pivot point of the lever and a force of 191.17 N was determined from the analysis of the solid linkage. The fixed support on the fulcrum end of the gear lever accurately models the load case specified, which is that the shifter is jammed in neutral position.

To accurately model the weld size, it was decided that a 3 mm fillet be applied to the welded section to bond the plate to the round fulcrum. The result can be seen in Fig. 33.

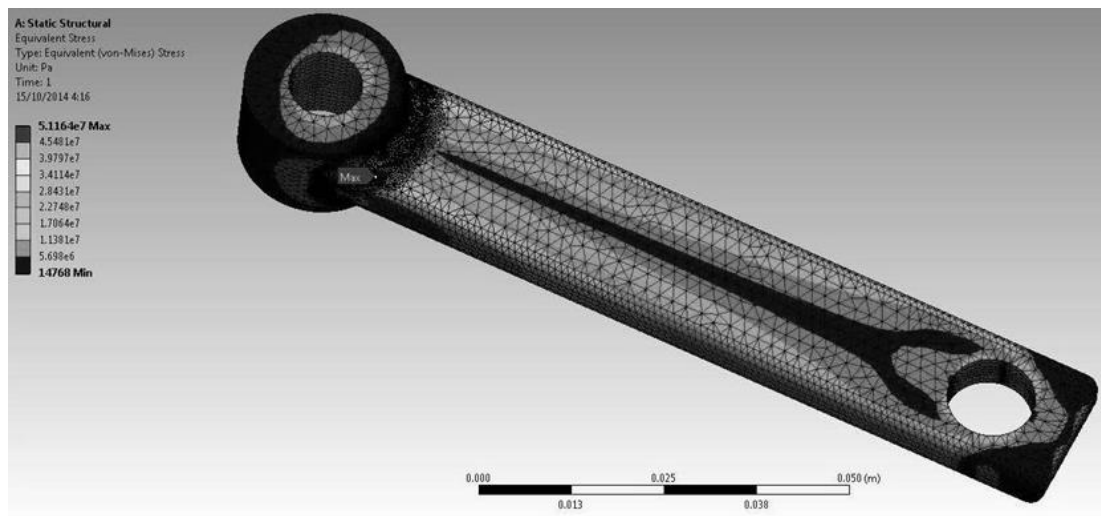

Fig. 3. Equivalent stress results of the gear lever

A maximum stress of 51.16 MPa occurred at the edge of the fillet, at each side of the pivot. A total deformation and strain of 11.4 μm and 0.256 μ, respectively, resulted in a safety factor of 1.334. Tab. 5 gives a summary of the FEA for all parts.

Tab. 5.

Summary of the FEA results

	Max stress, MPa	Max strain, μ	Max disp., mm	Fatigue safety factor	Reaction force, N
Mechanical shifter	63.1	315.5	0.05	1.096	190
Solid linkage	-	-	0.036	7.899	191.17
Spline attachments	51.16	256.0	0.0114	1.334	-

#### 4. SUPPORTING CALCULATIONS

Trigonometric analysis was used to calculate the length of each part. The gearbox was analyzed and it was determined that approximately 20° of rotation is needed to change gears [4]. The other design lengths were calculated with a set travel distance of 30 mm, a set linkage length of 1.146 m and a gearbox rotation of 20°. The dimensions were initially obtained by measuring the 3D Solidworks manufacturing drawings and once the frame was built, the genuine measurements were determined.

The dimension of the shifter was designed according to these specifications (Fig. 4), which assure a limited range of movement to acquire the stated distance to perform a gear change.

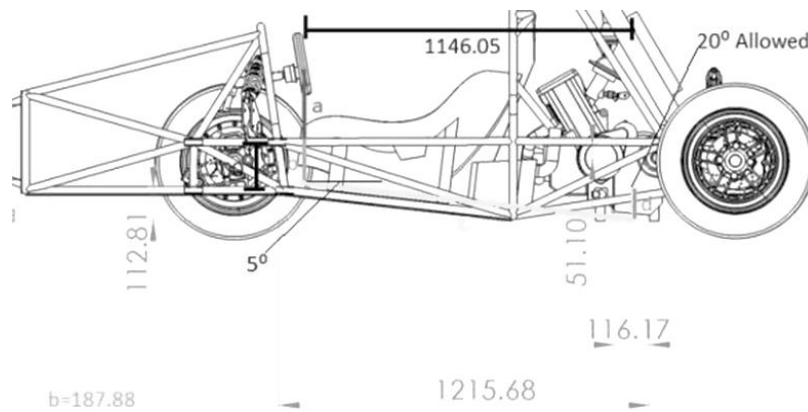

Fig. 4. Fixed geometric dimensions of the shifter mechanism

## 5. TECHNICAL SPECIFICATIONS

Fig.5 displays the final design to show the configuration of components in the required mounting position. The shifter grip design includes a carbon fiber mold over an aluminum base. This component was manufactured from a different material to reduce the weight, which otherwise would make up nearly 30% of the assembly weight based on the volume. Variable height mounting holes were allocated on the shifter base for height adjustment and grip attachment holes allow for modified grip components to be installed. The solid linkage has been designed to travel beneath the fuel tank and through the firewall. It can also be noted that the gearbox attachment creates a 90° angle to the linkage, which is optimal for gear shift force translation.

Tab. 6 has been generated to display the technical specifications of the material required to manufacture designed components and show the approximate cost associated with each item.

Note: Approximate cost does not include the cost associated with the fabrication or manipulation of components due to the assumption that JCM workshop facilities can be used.

Tab. 6.

### Specifications of material required

Component Name	Material Description	Dimensions in mm	Supplier	Approximated Cost in \$
Solid Linkage	CHS	10 O.D. 8 I.D. 1300 length	BPF Manufacturing	55
Shifter Body	Flat bar	30 x 6 x 400	One Steel TSV	45
C Bracket	AISI 1040 channel section	90 x 24 x 6	One Steel TSV	20
Spline Attachment	Bar welded to splined attachment	16 x 6 x 110	One Steel TSV	25
Shifter Grip Base	Aluminum bar	25 x 6 x 300	Capral	30



Carbon Grip Mold	Carbon fiber sheet around aluminum base	500 x 300	Fiber Finish TSV	40
Total				215

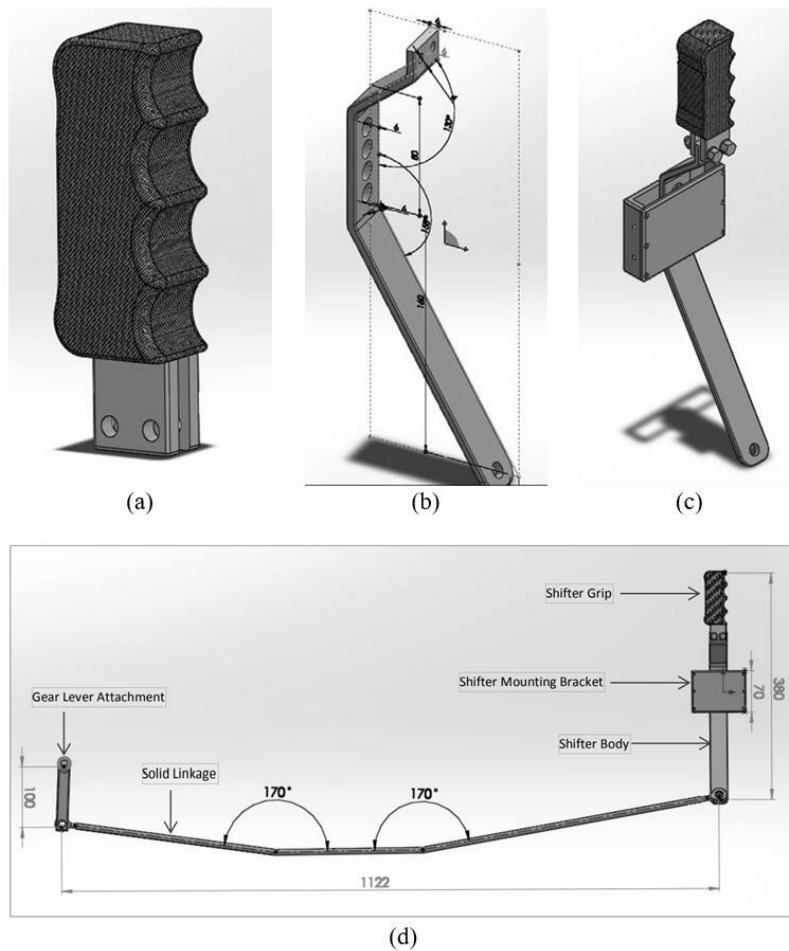

Fig.5. Shifter’s (a) grip, (b) body, (c) mounting, and (d) assembly

Tab. 77 displays the technical specification of the off-the-shelf components required in the shifter mechanism assembly and their associated costs.

Tab. 7.

Specifications for off-the-shelf components

Part Number	Name	Supplier Detail	QTY	Approximated cost in \$
470011	BJT-M8 Rod End	Elesa	2	40
17312	M8 Bolt and nut set	Supercheap	4	6

17492	M8 washers	Supercheap	4	6
Total				52

Based on the above cost approximation, the total cost for the shifter mechanism is \$267, which is within the allocated budget of \$300.

## 6. CONCLUSIONS

The objective of this work was to design a replacement shifter mechanism for the 2014 model JCU Motorsports FSAE car following the relevant Australian standards and FSAE rules.

First, after comparing several design options, the solid linkage shifter was chosen due to its reliability and cost. The main components of the system are mechanical shifter, solid linkage, and spline attachments.

Second, the AISI 1040 Steel was selected for the manufactured parts except for the shifter grip, which was made from carbon fiber layers over an aluminum core.

Third, design load cases were determined based on the data generated from the hand strength of males according to the Man-Systems Integration Standards [5].

Finally, FEA was performed based on the worst-case scenarios. Results showed that the design has positive safety factors and is capable of infinite life.

It could be concluded that all constraints and project outcomes were satisfied and conformed in this design which is also cost-effective, simple to manufacture and maintain, and reliable while maintaining high responsiveness and functionality.

## References

1. Capral. "Geometric Aluminium Flat Bar". Available at: <http://www.capral.com.au/Flat-Bars>.
2. Carbon Fibre Australia. "CF Sheets 2x500 Square". Available at: <http://www.carbonfiber.com.au/prod2.htm>.
3. Locust USA. "Hayabusa Shift lever". Available at: <http://www.locostusa.com/forums/viewtopic.php?f=10&t=13415>.
4. Maláková Silvia, Matej Urbanský, Gabriel Fedorko, Vierošlav Molnár, Samuel Sivak. 2021. „Design of Geometrical Parameters and Kinematical Characteristics of a Non-circular Gear Transmission for Given Parameters”. *Applied Sciences* 11(3): 1-23. DOI: 10.3390/app110311000. ISSN: 2076-3417.
5. NASA. "Man-Systems Integration Standards: Volume I - Standards". Available at: <http://msis.jsc.nasa.gov/volume1.htm>.
6. One Steel Metal Centre. "Flat bar 1040". Available at: <http://www.onesteelmetalcentre.com/products/merchant-bar/flat-bar>.
7. Orrcon Steel. "Precision Circular Section". Available at: <http://www.orrconsteel.com.au/en/australian-steel-products/tube-and-pipe/precision-steel-tubing/circular>.
8. Roymech. "Metal Fatigue and Endurance". Available at: [http://www.roymech.co.uk/Useful\\_Tables/Fatigue/FAT\\_Mod\\_factors.html](http://www.roymech.co.uk/Useful_Tables/Fatigue/FAT_Mod_factors.html).

9. Society of Robots. “Actuators - Solenoids”. Available at:  
[http://www.societyofrobots.com/actuators\\_solenoids.shtml](http://www.societyofrobots.com/actuators_solenoids.shtml).
10. USC Racing. “Electro-Pneumatic Systems for Formula SAE Application”. Available at:  
<http://uscracing.wikispaces.com/Electro-Pneumatic+Shifting>.
11. USC Racing. “Formula SAE Shifting Mechanism Design”. Available at:  
<http://uscracing.wikispaces.com/Shifter+Design+101>.

Received 12.10.2021; accepted in revised form 19.11.2021



Scientific Journal of Silesian University of Technology. Series Transport is licensed under a Creative Commons Attribution 4.0 International License