

JCU ePrints

This file is part of the following reference:

Turner, Ash (2011) *Paws for thought: exploring a framework for understanding the mediating role of dogs in people's learning processes in vocational education and training settings. A qualitative study of the use of dogs as mediating artifacts in Australian vocational education and training settings in the Townsville region.* PhD thesis, James Cook University.

Access to this file is available from:

<http://eprints.jcu.edu.au/18164>

Paws for Thought:
Exploring a Framework for Understanding the Mediating Role of Dogs in People's
Learning Processes in Vocational Education and Training Settings.

A qualitative study of the use of dogs as mediating artifacts
in Australian vocational education and training settings in the
Townsville region

Thesis submitted by
Ash Turner CIV TAA, Dip Bus, Dip Mgt, BBus, MEd

April, 2011

for the degree of Doctor of Philosophy
in the School of Education
James Cook University

STATEMENT ON THE CONTRIBUTION OF OTHERS

Nature of assistance	Contribution	Names, titles and affiliations of co-contributors
Intellectual support	Proposal writing	Dr Reesa Sorin, Senior
	Data analysis	Lecturer, School of
	Editorial assistance	Education, James Cook
	Proofreading	University
		Associate Professor
		Melissa Vick, Director of
		Research, School of
		Education, James Cook
		University
Editorial support	Editorial assistance and	Tanya Bowes-McKee,
	proofreading limited to matters listed in Standards D and E of the Australian Standards for Editing Practice.	Brisbane
Financial support	\$1,150 student support for editing, printing and	James Cook University
	binding.	

DECLARATION ON ETHICS

The research presented and reported in this thesis was conducted within the guidelines for research ethics outlined in the *National Statement on Ethics Conduct in Research Involving Humans* (1999), the *Joint NHMRC/AVCC Statement and Guidelines on Research Practice* (1997), the *James Cook University Policy on Experimentation Ethics. Standard Practices and Guidelines* (2001), and the *James Cook University Statement and Guidelines on Research Practice* (2001). The proposed research methodology received clearance from the James Cook University Animal Research Ethics Review Committee (approval number A1149) and Human Research Ethics Review Committee (approval number H2455).

8 April, 2011

Ash Turner

Date

ACKNOWLEDGEMENTS

To Reesa Sorin, for her patience, unending help and support and constant critique. You have challenged me every step of the way, have never accepted second-best and have always pushed me to realise my potential.

To Melissa Vick for her wisdom, prudence, guidance, encouragement and faith in my capabilities.

To John Cornwall, Sandra Glaister and Averil Plath from Delta Society Australia for their support, commitment and enthusiasm for this research, and for volunteering the services of their dogs and handlers.

To Adonis, Lady, Buddy and their handlers for volunteering their time and for their efforts in making this research possible.

To Christie, Robbie, Gemma, Sixpack, Knuckles, Thomas, Wilson and all the other dogs I have known and loved and who provided the inspiration for this research.

To Luke and Robert, my physiotherapists, for relieving the back and muscle aches in the final months of this thesis, caused by spending endless hours in front of a computer.

To Jean for her support, faith and encouragement.

To Peter for encouraging and exciting me to take up this journey and to see it through to completion.

Finally, to Zack, for teaching me about myself: to be patient, flexible and tolerant, and to let go and enjoy the simple things in my life at the times when it mattered most.

ABSTRACT

This research aims to explore and develop a framework for understanding the mediating role of dogs in people's learning processes in vocational education and training settings. Specifically, it aims to answer two questions: In what ways do people use dogs as mediating artifacts in their meaning-making processes; and what are the effects of dogs in mediating individual and group learning processes?

This study examines the lived experiences and reflections of 15 students and their teachers who interacted with three dogs during a six and a half day vocational education and training course. The course was held in a major regional centre in northern Australia by a private training provider. The research employed six data collection techniques: a pre-course questionnaire; classroom observations; a critical events technique; the repertory grid technique; post-course interviews; and the researcher's personal journal.

The results of this study suggest that there were four dichotomous dimensions of people's use of the dogs: Active—reFlective (A—F), Initiating—Responding (I—R), Material—Conceptual (M—C) and Spontaneous—Planned (S—P). These dimensions appear to resonate with three of the Big Five dimensions of personality. The Big Five dimensions of personality have been used to understand the different ways in which people learn. This suggests that people's use of the dogs as artifacts may share possible relationships with dimensions of personality and people's learning styles. Exploring these relationships suggested a previously hidden dimension of artifact use, Emotional—Logical (E—L), that may be congruent with another dimension of personality. Additionally, these dimensions appear to share dynamic relationships that may provide a deeper understanding of how people used the dogs as artifacts, by illustrating how they work and interact together. The results of this study also revealed

the functioning of individual preferences within these dimensions, which may have been moderated by a number of factors.

The results of this study suggest that the mediating role of the dogs may be understood by the way they appeared to have functioned as artifacts in three domains of the learning environment: cognitive, affective and social. In the cognitive domain the dogs may be seen to have functioned as artifacts by stimulating arousal, attention, focus and concentration through positive distraction. In the affective domain the dogs may be seen to have functioned as artifacts by: triggering positive emotional responses to arousal; stimulating feelings of enjoyment, calm, warmth and peace; and by fostering a relaxed and informal atmosphere. In the social domain the dogs may be seen to have functioned as artifacts by: serving as a social ice-breaker, providing a value-free conversation starter; and by functioning in people's perceptions of others through the use of social axioms, which may have factored in the construction of their social relationships.

This study is significant because it provides new knowledge by offering a framework for understanding the mediating role of dogs in people's learning processes. It therefore provides a map to understand in what ways dogs may be seen to function as artifacts and how this works. It also opens up ways of seeing and understanding what may occur in other settings, and provides new ways of being attentive to what happens in the classroom. The examination of the processes that take place during people's interaction with the dogs also provides new knowledge by offering a framework to understand how and why these interactions make the results reported by researchers possible. It may therefore open the way for improving animal assisted therapy and education programmes, and adapting them to situations beyond therapeutic and childhood education settings.

This study holds significance for practitioners because it provides the opportunity to broaden traditional theories of artifacts and artifact use to include animals alongside the inanimate. It may also extend established understandings of artifacts and their use in the classroom. This understanding suggests the importance for practitioners to know how to use artifacts in different ways, and to show and teach those ways to others. This study holds further significance for practitioners because it reveals insights into how teachers may bridge the teacher—student divide by balancing their traditional focus on assessable outcomes and the task environment, with students' inherently social learning processes.

TABLE OF CONTENTS

DECLARATION ON ETHICS	iii
ACKNOWLEDGEMENTS	iv
ABSTRACT.....	v
TABLE OF CONTENTS.....	viii
LIST OF TABLES.....	xi
LIST OF FIGURES	xiv
CHAPTER 1: INTRODUCTION	1
Background	1
Significance of the Research.....	5
Methodological Approach	6
Research Questions.....	8
Summary	9
CHAPTER 2: SETTING THE CONTEXT	11
Introduction.....	11
Contemporary Models of Teaching and Learning.....	11
Australian Vocational Education and Training	14
A Sociocultural Framework for Teaching and Learning.....	21
Mediating Artifacts of Human Action and Understanding.....	26
Modes of Using Dogs as Artifacts.....	43
Summary	55
CHAPTER 3: METHODOLOGY	56
Introduction.....	56
Research Framework	56
Research Design	58
Ethical Considerations	61
Data Collection Tools	63
Environmental Context.....	70
Research Participants.....	70
Procedure	72
Trustworthiness.....	77
Analysis	90
Summary	103
CHAPTER 4: RESULTS.....	106
Introduction.....	106
Participants.....	106
Questionnaire Data	116
Course Summary.....	122
Observational Data	122
Interview Data.....	166

Repertory Grid Data.....	218
Summary.....	254
CHAPTER 5: DISCUSSION.....	256
Introduction.....	256
Mediation: The Effects of Dogs on the Learning Environment	257
Artifact Use: The Ways in Which People Use Dogs as Mediating Artifacts ..	278
Summary.....	319
CHAPTER 6: SUMMARY AND CONCLUSIONS.....	322
Introduction.....	322
Artifact Use.....	326
Mediation	330
Implications for Practitioners.....	334
Implications for Further Research	339
Significance and Limitations of the Research	342
Lessons Learned	345
Concluding Remarks.....	360
BIBLIOGRAPHY	362
APPENDIX A: RESEARCH INTO ANIMAL—HUMAN RELATIONSHIPS	403
APPENDIX B: PRE-COURSE QUESTIONNAIRE	416
APPENDIX C: EVENT INTERVIEW GUIDE	418
Start the Discussion	418
Generate Discussion	419
During the Discussion.....	420
Close the Discussion.....	420
APPENDIX D: REPERTORY GRID TECHNIQUE.....	422
Technique.....	423
APPENDIX E: REPERTORY GRID TECHNIQUE DISCUSSION GUIDE	431
Start the Discussion	431
Introduce the Repertory Grid Technique	432
During the Discussion.....	435
Close the Discussion.....	436
APPENDIX F: ENVIRONMENTAL CONTEXT OF THE RESEARCH	437
Macro-Environment.....	437
Mezzo-Environment	439
Micro-Environment	442
APPENDIX G: SAMPLE INTERVIEW ANALYSIS.....	446
Thematic Discussion.....	487
APPENDIX H: SAMPLE OBSERVATION ANALYSIS.....	495
APPENDIX I: TEMPORAL MAPS OF OBSERVATIONAL DATA	507
Day 1, Tuesday, 6 February, 2007.....	507

Day 2, Wednesday, 7 February, 2007.....	511
Day 3, Thursday, 8 February, 2007	515
Day 4, Friday, 9 February, 2007	519
Day 5, Tuesday, 13 February, 2007.....	523
Day 6, Wednesday, 14 February, 2007.....	527
Day 7, Thursday, 15 February, 2007	531
APPENDIX J: STATISTICAL ANALYSIS OF REPERTORY GRID DATA.....	533
Bivariate Statistics: Construct and Element Correlations.....	534
Principal Component Analysis	535
Cluster Analysis.....	542
APPENDIX K: TEACHER, VISITOR AND STUDENT BEHAVIOURS.....	547
Lesson Types and Teaching Style	547
Visitors.....	550
Social Behaviours	552
Repeated Actions	558
Student Voices	565
Teacher Voices	573
Student Engagement	587
Additional Observations	594
APPENDIX L: DESCRIPTIONS OF ENVIRONMENTAL DOMAINS	599
Physical Domain	599
Task Domain.....	601
Cognitive Domain.....	619
Affective Domain	621
Social Domain.....	633
Teacher's Perspective of the Environmental Context.....	647
APPENDIX M: SAMPLE DETAILED ANALYSIS OF REPERTORY GRID	651

LIST OF TABLES

Table 1 Qualifications Within the Australian Qualifications Framework	15
Table 2 Summary of Papers on Animals and Quality of Life 1990-1995	39
Table 3 Research Audit Trail.....	85
Table 4 Extract from Analysis of Coral’s Critical Event Interview	93
Table 5 Results of Interview Code Reduction and Categories	97
Table 6 Results of Observational Code Reduction and Categories	100
Table 7 Synopsis of Participants.....	108
Table 8 Summary of Participant Attendance.....	113
Table 9 Participation Summary	115
Table 10 Participants’ Education Achievements	118
Table 11 Participants’ Experiences with Pets.....	119
Table 12 Perceived Advantages and Disadvantages of Dogs in the Classroom.....	123
Table 13 Course Structure and Outline.....	124
Table 14 Summary of Interview Participation.....	167
Table 15 Taxonomy of Domains and Characteristics of Dog Interaction	168
Table 16 Taxonomy of Environmental Domains and Characteristics.....	171
Table 17 Frequency Distribution of Emotional Attributes and Comments	184
Table 18 Comments Used to Describe Bond.....	189
Table 19 Comments Used to Describe Energy	190
Table 20 Comments Used to Describe Physical.....	192
Table 21 Comments Used to Describe Handler.....	193
Table 22 Comments Used to Describe Sociability	194
Table 23 Comments Used to Describe Initiator.....	196
Table 24 Comments Used to Describe Behaviour.....	198
Table 25 Comments Used to Describe Personality	199
Table 26 Comments Used to Describe Eye Contact.....	201

Table 27 Frequency Distribution of Attributes of Appeal.....	202
Table 28 Frequency Distribution of Human Agency Facets	209
Table 29 Summary of Constructs and Factor Loadings	221
Table 30 Summary of Principal Components.....	224
Table 31 Eigenvalues and Component Variance for Borat’s Grid.....	226
Table 32 Factor Loadings for Borat’s Grid	227
Table 33 Eigenvalues and Component Variance for Danni’s Grid	230
Table 34 Factor Loadings for Danni’s Grid.....	231
Table 35 Eigenvalues and Component Variance for Leigh’s Grid.....	234
Table 36 Factor Loadings for Leigh’s Grid	235
Table 37 Eigenvalues and Component Variance for Mary’s Grid	239
Table 38 Factor Loadings for Mary’s Grid.....	240
Table 39 Eigenvalues and Component Variance for Sam’s Grid.....	242
Table 40 Factor Loadings for Sam’s Grid	243
Table 41 Eigenvalues and Component Variance for Sharon and Dan’s Grid	247
Table 42 Factor Loadings for Sharon and Dan’s Grid.....	248
Table 43 Eigenvalues and Component Variance for Wynnies Grid	251
Table 44 Factor Loadings for Wynnies Grid.....	252
Table 45 Principal Components Describing Socialisation	272
Table 46 Comparison of Personality Dimensions and Artifact Use.....	285
Table 47 Description of Preferences in Each Dimension	294
Table 48 Constructs Describing Preferences in Each Dimension	298
Table 49 Principal Components Describing Active—Reflective (A—R) Preferences	301
Table 50 Descriptions of Dimensions of Artifact Use.....	327
Table F1 Competency Outcomes.....	442

Table J1 Sample Randomisation Test.....	536
Table J2 Sample Eigenvalues and Component Variance for Grid Data.....	538
Table J3 Sample Factor Loadings.....	540
Table K1 Behaviours that Exemplify Attending to Personal Needs	552
Table K2 Frequency Distribution of Visitor Behaviours.....	553
Table L1 Frequency Distribution of Structural Characteristics.....	605
Table L2 Teaching and Learning Comments by Participant	607
Table L3 Comments Used to Describe Self-Efficacy.....	610
Table L4 Comments Used to Describe Interpersonal Skills.....	612
Table L5 Comments Used to Describe Professional Practice	615
Table L6 Frequency Distribution of Competency Facets and Attributes	618
Table L7 Frequency Distribution of Emotional Characteristics.....	627
Table L8 Frequency Distribution of Motivation Characteristics.....	630
Table L9 Description of Facets of Human Agency	634
Table L10 Frequency Distribution of Human Agency Facets.....	641
Table L11 Frequency Distribution of Socialisation Facets	648
Table M1 Randomisation Results for Danni’s Grid	657
Table M2 Construct Correlations for Danni’s repertory grid.....	658
Table M3 Element Correlations for Danni’s repertory grid	660

LIST OF FIGURES

Figure 1. Sample repertory grid.....	68
Figure 2. Participants' orientation towards dogs.....	117
Figure 3. Number of occasions that participants talked about and to dogs.....	162
Figure 4. Frequency of participants talking about and to dogs.....	163
Figure 5. Biplot for Borat's repertory grid.....	228
Figure 6. Biplot for Danni's repertory grid.....	232
Figure 7. Biplot for Leigh's repertory grid.....	237
Figure 8. Biplot for Mary's repertory grid.....	241
Figure 9. Biplot for Sam's repertory grid.....	244
Figure 10. Biplot for Sharon and Dan's repertory grid.....	249
Figure 11. Biplot for Wynnie's repertory grid.....	253
Figure 12. Graphical representation of dimensional dynamics.....	289
Figure 13. Axial grids required to explain dynamics of preference.....	290
Figure 14. Matrix descriptions of dimensional dynamics.....	291
Figure 15. Matrix of dynamic relationships between dimensions.....	329
Figure D1. Completed repertory grid.....	430
Figure F1. Training room layout configuration.....	444
Figure I1. Temporal map for teaching period 1.1.....	507
Figure I2. Temporal map for teaching period 1.2.....	508
Figure I3. Temporal map for teaching period 1.3.....	509
Figure I4. Temporal map for teaching period 1.4.....	510
Figure I5. Temporal map for teaching period 2.1.....	511
Figure I6. Temporal map for teaching period 2.2.....	512

Figure I7. Temporal map for teaching period 2.3.....	513
Figure I8. Temporal map for teaching period 2.4.....	514
Figure I9. Temporal map for teaching period 3.1.....	515
Figure I10. Temporal map for teaching period 3.2.....	516
Figure I11. Temporal map for teaching period 3.3.....	517
Figure I12. Temporal map for teaching period 3.4.....	518
Figure I13. Temporal map for teaching period 4.1.....	519
Figure I14. Temporal map for teaching period 4.2.....	520
Figure I15. Temporal map for teaching period 4.3.....	521
Figure I16. Temporal map for teaching period 4.4.....	522
Figure I17. Temporal map for teaching period 5.1.....	523
Figure I18. Temporal map for teaching period 5.2.....	524
Figure I19. Temporal map for teaching period 5.3.....	525
Figure I20. Temporal map for teaching period 5.4.....	526
Figure I21. Temporal map for teaching period 6.1.....	527
Figure I22. Temporal map for teaching period 6.2.....	528
Figure I23. Temporal map for teaching period 6.3.....	529
Figure I24. Temporal map for teaching period 6.4.....	530
Figure I25. Temporal map for teaching period 7.1.....	531
Figure I26. Temporal map for teaching period 7.2.....	532
Figure J1. Sample biplot representing a person's construct space.	542
Figure J2. Sample cluster analysis of constructs.	544
Figure J3. Sample cluster analysis of elements.	546
Figure K1. Frequency of participants leaving the room.	559
Figure K2. Frequency of participants retrieving printing.....	560

Figure K3. Frequency of participants getting a drink.....	561
Figure K4. Frequency of participants using mobile phones.	562
Figure M1. Raw repertory grid for Danni.....	652
Figure M2. Cluster analysis of elements from Danni’s repertory grid.....	662
Figure M3. Cluster analysis of constructs from Danni’s repertory grid.....	663

CHAPTER 1: INTRODUCTION

The wealth of research on the power of the human-animal bond tells us one thing: the healing power of pets isn't anecdotal anymore, but scientific... It is our fervent wish that more and more people will understand the scientific basis of the human—animal bond and appreciate the roles animals play in improving the quality of our lives. (Creagan, 2002, p. 3).

Background

The benefits of interacting with animals has been the subject of research over the past few decades and as Creagan (2002) suggests, it affects people emotionally, physically and psychologically. One of the often cited benefits is that it can induce relaxation (Anderson, Reid, & Jennings, 1992; Archer, 1997; Katcher, Friedman, Beck, & Lynch, 1983; McLaughlin, 2003; Messent, 1983; Serpell, 1990; Soares, 2003). However, the benefits of interacting with animals are not limited to increased feelings of calm. They also include: improved self-esteem (Bardill, 1997); increased energy and physical interaction (Burgess, 1997); reduced tension, depression, vigour and fatigue (Crowley-Robinson, Fenwick, & Blackshaw, 1996); decreased blood pressure (Katcher, et al., 1983); reduced minor health problems (Serpell, 1991); and increased appetite, responsiveness and mental alertness (Heimlich, 2001). Studies also describe that interacting with animals in therapeutic and childhood education settings can also benefit people's learning processes. These benefits include: cognitive improvement (Heimlich, 2001); improved functioning of children with conduct disorder and attention deficit hyperactivity disorder (Katcher & Wilkins, 1994); increased length and complexity of sentence structures, intelligibility, peer interaction and communication (Anonymous, 2003); improved cognitive development (Kotrschal & Ortbauer, 2003); accelerated learning (Katcher & Wilkins, 1994); increased motivation (Goodwin, 1999); improved

student achievement (Baker, 1987); improved literacy (Townsend, 2003); enhanced verbal communication (Batson, McCabe, Baum, & Wilson, 1998); increased attention span (Heimlich, 2001); and increased learning (Miller et al., 2003),

However there appears a dearth of attempts to uncover reasons to fully explain or understand the phenomenon and to date it remains unclear why or how these benefits are realised. This poses the question: What processes take place when people interact with animals that make these results possible? Deepening an understanding of these processes may reveal why animal assisted therapy and education practices produce the benefits reported by researchers. This may point towards opportunities to improve these practices and adapt their principles to new and different settings. Furthermore up till now, the educational focus within the literature on animal—human interactions has been on childhood settings up to and including high school, and there appears an absence of similar research in adult learning situations. This raises an opportunity to explore the cross-over of understandings derived from animal assisted therapy and education, from childhood pedagogies to adult andragogies.

Many vocational education and training settings today are characterised by a behaviouristic and subject-centred model that sees all learning reduced to knowledge, skills or attitudes, and emphasises direct and practical results (Clark, 1995; Cornford, 2004; Hyland, 1997; Tusting & Barton, 2003). As such, little attention is paid to the practical realities of effective teaching and learning issues, learning-to-learn elements and the affective issues in skill learning (Australian Chamber of Commerce & Industry, 2002; Sanguinetti, Maunders, & Waterhouse, 2003). In Australia such an approach to adult learning characterises the vocational education and training sector where accredited post-secondary vocational qualifications are issued through the Australian Qualifications Framework and Australian Quality Training Framework. Hyland (1997)

suggests that a behaviouristic and subject-centred approach to vocational education and training, stifles creative learning, ignores individual learning styles and preferences, and devalues the learning process by focusing on testing outcomes. McMurtry (2004) argues that this is evidenced by an orientation towards efficiency, a desire for control over instruction and learning outcomes, and a transactional view of learning that constructs students as empty vessels waiting to be filled with knowledge.

Additionally, businesses today are facing challenges that affect people's socialisation and therefore may possibly be dehumanising the individual (Botaris, 2003; Colteryahn & Davis, 2004). Among these challenges is an increased use of technology and a decrease in the amount of classroom learning in order to lower training times and costs. Businesses are also increasing their focus on the evaluation and measurement of behavioural outcomes against their bottom-line business results. Finally, enterprises are facing an increase in globalisation and economic competition, and changing patterns of work towards teleworking and non-traditional hours. Theories of learning may have been adequate for previous societies where rates of change were arguably slower and the need for learning was less. However, in a contemporary, rapidly changing world, there are pressures for people to learn all the time. The new knowledge economy necessitates being able to adapt quickly to change by learning. This entails rapidly-shifting communication practices and changing contexts that some have attempted to address by online and distance learning (Edwards, Sieminski, & Zeldin, 1993; Gee, Hull, & Lankshear, 1996). Hochschild (1997) and Sennett (1998) argue that theories of adult learning should reflect the need for this rapid learning, and that changing work practices call for new models of practice.

However, adult learning may be viewed as a more complex process than the simple acquisition of knowledge, skills and attitudes implied by the contemporary

models of teaching and learning that characterise Australian vocational education and training. For example, Alfred (2003), Calder (1993), Clark and Wilson (1991), Flowers (2003), Hanson (1996), Jarvis (1987, 1992), Lee (2003), Pratt (1991, 1993) and Shared (1994) argue that adults live, operate and learn in a social context and environment through which they construct and situate their own understandings that are consistent with their own world view.

A social constructivist view of adult learning is supported by a recent study completed for the Australian Government by the University of New England. This study suggested that the principal hurdle to further education for some Australians is the feeling of anxiety, which infers that many do not think of themselves as good learners and lack confidence in their own abilities (Department of Education Science and Training, 2003). This study also found that making the learning process an informal and social experience, as opposed to one based on formal assessment, assists people in overcoming their anxiety. As a result the Australian Department of Education, Science & Training (2003), emphasise the importance for training providers at all levels of industry and community to create a learning environment that promotes positive self-esteem and self-worth. They posed questions for discussion and consultation that included: What do we know about adult learners? What are the most effective ways to communicate with adults to engage them in the learning process? How can providers ensure that they are creating a positive learning environment? These are questions that this study may help to answer by exploring the effects of animal—human interactions on vocational education and training settings.

This study is founded on the question: If animal—human interactions can help realise cognitive, affective and social benefits in therapeutic and childhood educational settings, what is their potential for adult learners? The choice of dogs as the animals for

this research was informed by their use in therapeutic and childhood education settings. They are also the subject of a large number of studies that can be drawn on to help shape and inform this research (Watson, 1998). Finally, dogs enjoy a rich symbiotic co-evolution and relationship with humans that is unequalled by any other domestic animal (Coppinger & Coppinger, 2001; Messent & Serpell, 1981; Newby, 1999, 2001; Paxton, 1994; Price, 2002; Utlah, 2003; Wade, 2002; Zawistowski, 2003).

Significance of the Research

This study aims to provide new knowledge by offering a framework for understanding the mediating role of dogs in people's learning processes in vocational education and training settings. It therefore seeks to provide a map to understand in what ways dogs may be seen to function as artifacts and how this works. This study seeks to examine the processes that take place during people's interaction with dogs and to provide new knowledge by offering a framework to understand how and why these interactions make the results that are reported by researchers possible. It may therefore open the way for improving animal assisted therapy and education programmes, and adapt them to situations beyond therapeutic and childhood education settings.

This study explores the notion of animals in the classroom as mediating artifacts, that is, tools that stand between people and the world that help them interpret and make sense of it. It also aims to extend established understandings of artifacts and their use in the classroom and examines the opportunity to broaden traditional theories of artifacts and artifact use to include animals alongside the inanimate. For practitioners, this study also aims to help bridge the teacher—student divide by levelling the imbalance between assessable outcomes and students' learning processes that are inherently social. For the broader community, this research aspires to deepen an understanding of people's interactions with dogs and the nature of the animal—human

bond. Its ambition is to enhance traditional perspectives on the value of dogs in improving the quality of life, and to reconsider their roles in areas of society where traditionally they have been less visible.

Methodological Approach

This study has focused on the lived experiences and reflections of 15 students and their teachers who interacted with three dogs during a six and a half day vocational education and training course. The course was held in a major regional centre in northern Australia by a private training provider. The course, *TAA40104 Certificate IV in Training and Assessment*, is the entry-level qualification required for practitioners to deliver and assess accredited training. It was chosen as the learning context in this research because it was a representative example of classroom-based training located in vocational education and training sector. Only one dog was present in the classroom at any one time. There were no restrictions placed on the dogs, and they were allowed to roam freely around the classroom during the lessons. The interaction with the dogs was not structured, in order to allow the people to choose the ways and times that were most appropriate and meaningful. In other words, this study aims to reveal emergent, rather than imposing pre-determined methods of using the dogs.

This research used six techniques to collect data: a pre-course questionnaire, classroom observations, a critical events technique, the repertory grid technique, post-course interviews, and the researcher's personal journal. A pre-course questionnaire was used to capture the demographic data concerning the participants and to help build a picture of their backgrounds. Classroom observations were recorded for the duration of the course using running records, and semi-structured interviews were used to capture perceptions and reflections on people's experiences following critical events that occurred during the class. George Kelly's (1955) repertory grid technique enabled

people to verbalise how they perceived elements or facets within the classroom domain, which helped construct a picture of their concept models. It also served as a tool for the collection of students' and teacher's narratives on the completion of the course by stimulating dialogue. Finally, the researcher's journal revealed information about self and method at regular and spontaneous moments during the life of the research.

Analysis of the interview and observational data drew on grounded theory to develop hypotheses to explain identified phenomena. It used an iterative analytical process that employed two inductive strategies. First, it used constant comparison where concepts and categories that emerged from one piece of data were compared with others to explore the possible relationships between them. Second, it used analytic induction where hypotheses were formulated around an instance of a phenomenon, and through an iterative process of comparison with other occurrences, it was continually refined to account for all of them. Repertory grids were analysed using Idiogrid (Grice, 2007) and GridSuite (Bacher & Fromm, 2004) software to produce bivariate statistics, and conduct principal component and cluster analyses. Bivariate statistics were used to examine the relationships between constructs and elements. Principal component analysis was used to compress constructs to a smaller number that accounted for the spread of data. Cluster analysis was used to examine natural groupings amongst constructs and elements, and the similarities and differences they shared.

The results of this study are however not without their limitations. First, the results are limited to one group of classroom participants, in one environment, during one six and a half day training course. It therefore provides one instance of one group's use of dogs at one point in time, and the meanings they came to understand from their interactions with them. To this end, this study cannot claim results that are generalisable to other settings, and it does not seek to do so. What it can and does offer is a way to

understand and conceptualise what happened for this group of people in this setting. It therefore provides an analytical framework for understanding the mediating role of dogs in people's learning processes on which to scaffold strong theory building when more extensive data is available. It also provides a map to understand in what ways dogs may be seen to function as artifacts and how this works, opens up ways of seeing and understanding what may occur in other settings, and provides new ways of being attentive to what happens in the classroom.

The results of this research are also limited by environmental factors that may have moderated the effects reported in this study. Furthermore the length of exposure afforded by the duration of the course may have factored as an additional limitation. A course conducted over several months may have produced different results. Finally, this research is anchored in regional Australian and Anglo-American culture. Therefore the results may be limited in indeterminate ways by the values, beliefs and perceptions of one particular culture.

Research Questions

The aim of this research is to explore and develop a framework for understanding the mediating role of dogs in people's learning processes in vocational education and training settings. Specifically, this study aims to answer two research questions: In what ways do people use dogs as mediating artifacts in their meaning-making processes; and what are the effects of dogs in mediating individual and group learning processes?

The first research question focuses on aspects of people's methods of use or ways of operating the artifact that are suggested by the data, such as patting, observing and playing. This also includes the duration and conditions under which these uses took place. This understanding is deepened and enriched by exploring factors of artifact use.

These factors include the role of the context, the physical environment, ease and effort, what may be seen as oppression, rule making, perception, enculturation, and artifact functioning and appeal. The second research question focuses on the outcomes from people's interactions with the dogs.

These research questions focus this research clearly on the interactions between people and dogs in vocational education and training settings. It does not attempt to explore questions about the quality of learning or educational outcomes, or the quality of teaching, educational and learning processes. It does however, aim to provide an analytical framework for understanding the mediating role of dogs in people's learning processes on which to scaffold strong theory building when more extensive data is available. The results of this study aim to provide a way to conceptualise what might be measured and how research instruments and scales may be constructed, how other studies might be conducted, and offers a framework to analyse and interpret the results.

Summary

This chapter provided an introduction to the research study, and presented its foundational question: If animal—human interactions can help realise cognitive, affective and social benefits in therapeutic and childhood educational settings, what is their potential for adult learners? After outlining the methodological approach and describing the significance of this research, this chapter concluded by presenting the two research questions that this study aims to answer.

The following chapter discusses the context for understanding how dogs may be seen to function as mediating artifacts and stands in the place normally occupied by a review of the literature. It does both more and less than a conventional literature review. It reviews the body of literature that deals with crucial contextual aspects of the study and in addition it provides an analysis of primary documents to present an

understanding of vocational education and training in Australia. However other aspects of the literature which bear directly on the interpretation of findings are discussed within the context of those findings, rather than separate to them, where they are better placed to assist the reader.

The following chapter will draw from the literature to construct a framework for the research methodology that was employed in this study. It will also provide a detailed procedure for conducting the research, a description of the data collection tools and methods used, and a description of the techniques and methods employed to analyse the data. The results of the data collection are presented and explained in chapter 4 that also builds the logical chain of evidenced used to develop emergent hypotheses and findings that are discussed in chapter 5. The final chapter presents a summary of the key findings and conclusions, along with their implications for practitioners, policy makers and the wider community, and explores the value of further research. It will examine the significance and limitations of this study, along with key learnings that arose from the researcher's use of the dog as artifacts, and learnings that emerged from the researcher's reflections on the methodological approach.

CHAPTER 2: SETTING THE CONTEXT

Introduction

The following chapter discusses the context for understanding how dogs may be seen to function as mediating artifacts and stands in the place normally occupied by a review of the literature. It does both more and less than a conventional literature review. It reviews the body of literature that deals with crucial contextual aspects of the study and in addition it provides an analysis of primary documents to present an understanding of vocational education and training in Australia. However aspects of the literature which bear directly on the interpretation of findings are discussed within the context of those findings, rather than separate to them, where they are better placed to assist the reader.

Firstly, this chapter will examine the vocational education and training sector in Australia as an example of contemporary models of teaching and learning. This view of adult learning will be contrasted with the social constructivist framework that emerged from the Soviet school of sociocultural theory, central to which is the concept of artifacts that mediate human understanding. Finally, this chapter will examine several ways that dogs may be seen to function as artifacts in society, to provide a framework on which to scaffold thinking in answering the research questions.

Contemporary Models of Teaching and Learning

Vocational education and training in Australia is characterised by contemporary models of teaching and learning that McMurtry (2004) argues, focus on efficiency and control over instruction, and view learning as a transactional process. Tusting and Barton (2003) suggest that these models break complex learning into small, simple tasks that are practiced repeatedly and where students are rewarded for their correct completion. They argue that this approach offers simplicity and control, a method for

teaching complex behaviours in relatively straightforward ways, a method of measuring what has been achieved, and an attractive appearance of scientific rigour. At the centre of these approaches to teaching and learning are behavioural objectives that Clark (1995) describes as assessable written descriptions of specific pre-determined learning outcomes that are phrased in observable and measurable terms.

Foundations for the construction of behavioural objectives are rooted in the military and industrial psychology through the work of Mager, Gagne and Briggs who influenced educators during the 1960s and 1970s by developing a framework for task analysis¹ and criterion referenced instruction² known as instructional system design (Anglin, 1991; Gagne, 1985; Kearsley, 2004; Leigh, 2004; Mager, 1975). As noted by Clark (1995), Leigh (2004), Merrill, Lin and Jones (1990) and Saettler (1968), instructional system design has grown to be the most extensively used model in vocational education and training today.

However, Harrow (1972), Isaacs (1996) and Simpson (1966) argue that it is a behaviouristic and subject-centred model that sees all learning in each of the cognitive, psychomotor and affective domains of learning reduced to knowledge, skills or attitude. Additionally, Hyland (1997) suggests that such an approach is based on the reduction of learning to statements of competence derived from a functional analysis of occupational

¹ Task analysis refers to the process of breaking down instructional tasks into sequential steps that form a hierarchical relationship of tasks and subtasks (Mager, 1975).

² Criterion referenced instruction refers to a comprehensive set of methods for the design and delivery of training programmes based on the ideas of mastery learning and performance-oriented instruction (Mager, 1975).

roles. He argues that therefore, it does not acknowledge the role of context or the social system in which the individual lives and learns, and in which they construct and situate knowledge, skills and attitude. As Hyland (1997) and Grace (1996) point out, the individual as an agent of learning in these domains does not operate in a vacuum completely separate from a broader social framework; instead he or she is an integral part of it.

Similar criticism has been directed at other influential thinkers in the field of adult learning and education known as andragogy, including Brockett (2004), Boyd (1989), Daloz (1999), Dirkx (1998), Kegan (2000), Knowles (1980, 1990), Kolb (1984) and Mezirow (2000). These thinkers have been challenged by the suggestion that their theories do not fully acknowledge the social or cultural aspects of the learner (Brookfield, 2000; Caruth, 2000; Clark & Wilson, 1991; Collard & Law, 1989; Flowers, 2003; Freire, 1972; Grace, 1996; Hanson, 1996; Jarvis, 1987, 1992; Lee, 1999, 2003; Rowland & Volet, 1996; Travis, 1985; Tsuang, Paterson, & Packer, 2002). For example, it has also been argued that andragogy's theoretical framework is based largely on the white, male privileged ideologies of the younger, better educated and employed, and thus its universality may have neglected people from marginalised groups such as women, people of colour, working-class adults, adult immigrant learners, and people from socially dysfunctional environments by ignoring their experiences (Alfred, 2003; Brookfield, 1993, 2000; Flowers, 2003; Hvitfeldt, 1986; Lee, 1999, 2003; Marcano, 2001; Pratt, 1991, 1993; Rowland & Volet, 1996).

However, these contemporary approaches to teaching and learning continue to characterise Australian vocational education and training, despite the criticisms they have drawn.

Australian Vocational Education and Training

The Australian vocational education and training sector in Australia is governed by a national system for the achievement of post-secondary qualifications known as the Australian Qualifications Framework. Qualifications in the vocational education and training sector are implemented through the National Skills Framework and the Australian Quality Training Framework. These in turn establish standards for the achievement of skills and competencies in industry.

Australian Qualifications Framework

The Australian Qualifications Framework was introduced in Australia in January, 1995 (Australian Qualifications Framework Advisory Board, 2007). It comprises 15 qualifications divested across three different sectors: the secondary schools sector, the vocational education and training sector, and the higher education sector. Reported in Table 1 is a summary of the 15 qualifications issued under the Australian Qualifications Framework, which shows the authorities responsible for setting the standards of qualifications in each sector. Under the secondary schools sector is the Senior Secondary Certificate of Education. The vocational education and training sector comprises eight qualifications ranging from Certificate I through to Vocational Graduate Diploma. Finally, Diploma through to Doctoral Degree fall within the ambit of the higher education sector.

The claimed benefits of the Australian Qualifications Framework include consistency in the recognition of outcomes and flexibility to cater for the differing needs of each sector (Australian Qualifications Framework Advisory Board, 2007). This framework aims to assist people move between the three sectors and the labour market, by providing credit transfer and experience through a system that recognises prior learning. The Australian Qualifications Framework also promotes greater

Table 1

Qualifications Within the Australian Qualifications Framework

Secondary school sector	Vocational education and training sector	Higher education sector
		Doctoral degree
		Masters degree
	Vocational graduate diploma	Graduate diploma
	Vocational graduate certificate	Graduate certificate
	Advanced diploma	Bachelor degree
	Diploma	Associate degree
Senior Secondary	Certificate IV	Advanced diploma
Certificate of Education	Certificate III	Diploma
	Certificate II	
	Certificate I	

articulation of national and international qualifications and at the same time aims to encourage high quality vocational education and training to meet the demands of individuals and industry.

National Skills Framework

Prior to the introduction of the Australian Qualifications Framework in 1995, each state and territory in Australia operated its own system of standards for the provision of vocational education and training. The National Skills Framework was thus developed to: provide a consistent training system based on the attainment of competencies known as competency-based training; overcome the difficulties of a complicated vocational education and training system; and reduce the points of regulation (Australian Qualifications Framework Advisory Board, 2007; Duruz, 2007). The National Skills Framework aims to provide high quality skill outcomes to increase productivity and employment of individuals, and to improve the competitiveness of business enterprises and the national economy.

The concept of competency-based training on which the The National Skills Framework is founded, places the onus on individuals to demonstrate through practical example and physical evidence that they are able to perform a set of tasks. In this way, competency-based training can be seen to focus on outputs and criterion-referenced assessment rather than inputs and individual learning processes. However, because the focus is on measurable outcomes, a more descriptive term may be competency-based assessment.

Operating predominantly in the vocational education and training sector, the National Skills Framework comprises two key elements: a set of nationally agreed standards to ensure the quality of services known as the Australian Quality Training Framework; and a set of nationally endorsed standards for assessing the skills achieved by individuals known as training packages (Department of Education Science and Training, 2007a; Department of Education Training and the Arts, 2008).

The first element, The Australian Quality Training Framework, comprises four standards: *Essential Standards for Registration*; *Standards for State and Territory Registering Bodies*; *Standards for Accredited Courses*; and *Excellence Criteria*. The *Essential Standards for Registration* specify the requirements that training organisations must meet when delivering, assessing and issuing nationally recognised vocational qualifications and competencies (Department of Education Science and Training, 2007a; Department of Education Training and the Arts, 2008). An organisation that achieves registration against these standards is known as a registered training organisation. The *Standards for State and Territory Registering Bodies* specify the requirements against which training organisations are assessed for registration, and those that ensure the quality of services they provide (Department of Education Science and Training, 2007d; Department of Education Training and the Arts, 2008). The *Standards for Accredited Courses* sets out the requirements against which courses are measured and assessed for accreditation and recognition. (Department of Education Science and Training, 2007c; Department of Education Training and the Arts, 2008). The standards also include a set of voluntary *Excellence Criteria* that a registered training organisation may use to continually improve their quality of training and assessment (Department of Education Science and Training, 2007b).

The second element of the National Skills Framework comprises a set of nationally endorsed standards known as training packages. These standards set out in prescriptive competency-based terms, the skills and knowledge required to perform effectively within an occupation (Department of Education Science and Training, 2007e; Department of Education Training and the Arts, 2008). They are developed collaboratively by industry groups and business enterprises to meet the identified needs of commerce and receive endorsement by the National Quality Council. A common

misconception frequently experienced in the researcher's professional practice, is that a training package describe how a course of instruction should be delivered and includes the required teaching and learning resources. However, training packages provide little direction for the teacher and instead set out the standards to which a person is required to perform a job or task before they are able to be issued with a qualification.

These standards imply a degree of rigour around the conduct of competency-based training in the vocational education and training sector. However, several different perspectives have been offered on its efficacy.

Perspectives on Competency-Based Training

Jasinski (1996) argues that a lack of clear and agreed understanding on how competency-based training is defined has led to ambiguity and differing ideas amongst policy makers and practitioners on how it should be practiced. Collins (1993) and Jackson (1993) argue that competency-based training is a destructive, narrow, technical approach to training that is driven by the needs of bureaucracy and business. Smith (1999) suggests that it focuses on outcomes measured against specified standards that relate to industry rather than other students. Similarly, Hyland (1997) suggests that it reduces learning to statements of competence derived from a functional analysis of vocational roles, and focuses on the generation and collection of evidence to demonstrate competency. He argues that such a focus separates competency-based training from an active process of learning by stifling creativity, ignoring individual learning styles and preferences, and devaluing the learning process by focusing on testing outcomes. Additionally, Smith (1999) argues that competency-based training is an outcome driven approach that measures people as either *competent* or *not yet competent* and does not recognise levels of individual achievement. He attests that it

provides little incentive to excel, regardless of an individual's actual achievement or capability.

Nevertheless, competency-based training has grown into an industry driven by a competitive economic imperative. As Smith (1999) points out, prior to the National Skills Framework the main providers of training in the vocational education and training sector were the public Technical and Further Education Colleges. In 2003 there were over 3,100 private registered training organisations in Australia competing for over 2,200,000 students (Harris, Simons, & McCarthy, 2006). In 2007 these private registered training organisations were used by 21.9% of employers as their main provider of nationally recognised training (Department of Education Employment and Workplace Relations, 2007a).

The researcher's professional practice suggests that a reduced focus on the processes of learning may diminish qualifications to commodities that can be bought or sold. Registered training organisations may be seen to operate in a competitive market place and contend for income derived from selling qualifications. Where the qualification sold is the same regardless of the provider, there may be little incentive for students-as-consumers to pay a high price. The economic principle of supply and demand suggests that this situation may drive down the purchase cost of qualifications and encourage students to chase the lowest cost. Additionally, the outcomes driven focus of competency-based training may lead to a "tick-and-flick" approach where in the absence of grades of achievement, the process is reduced to an exercise on producing and gathering evidence. These elements, along with the reduced effort required on the part of the learner, and the responsibility for competency assessment resting with the trainer and provider, soon locates the attainment of qualifications in a fee-for-service paradigm. Smith (1999) suggests that this is further compounded by an

increasing necessity for providers to adopt commercial attitudes towards selling their courses.

Additionally, when the student-as-consumer pays a required fee, the contract of sale implies a burden on the provider to progress students through the required tasks and to assess them as competent so that the purchased qualification may be issued. Such a situation sees qualifications bought and sold as commodities without due regard to people's learning processes, and is colloquially referred to as "cheque-book training." This may lead to consequences such as short cuts, workarounds, and marginal or bad practices. These may be aggravated by a belief that a provider who repeatedly fails to meet the burden implied by the contract of sale may be less competitive in retaining existing customers and attracting new ones.

Despite these criticisms, competency-based training has influenced the way many business enterprises approach training their employees. Evidence of this influence can be found in a study by the Allen Consulting Group (1994) where 85% of Australian businesses surveyed, considered competency-based training to be an important and positive training development. Matthews (1999) suggests that many business enterprises today provide training to their staff in order to improve their skills and knowledge. Training assists businesses to meet the economic demands of competitive business growth as they respond to emerging trends, new markets, increased technology and changing customer needs. Additionally, the Australian Government encourages businesses to train their staff by providing financial incentives to open up training opportunities, by making expenditure on training tax deductible, and by supporting specific workplace skills and training initiatives (Department of Education Science and Training, 2003).

However, not all training provided by employers is accredited through the Australian Qualifications Framework. For example in 2009, 52.7 % of Australian employers reported that they used training that was not nationally recognised, such as training provided by a product supplier installing new equipment or software (Department of Education Employment and Workplace Relations, 1999). Yet as Matthews (1999) suggests, technical skills training remains the dominant learning paradigm in most organisations. This training focuses on the acquisition of specified bodies of knowledge or skills to meet identified tasks or job requirements. This resonates with instructional system design and competency-based training that characterise contemporary approaches to teaching and learning, and may attract similar criticisms.

These criticisms of competency-based training point towards a divide between teachers and their students created by an imbalance between assessable outcomes and people's learning processes. One way to bridge such a divide may be to restore this balance by exploring a sociocultural framework for teaching and learning.

A Sociocultural Framework for Teaching and Learning

Adult learning may be viewed as a more complex process than the simple acquisition of knowledge, skills and attitudes implied by the contemporary models of teaching and learning that characterise Australian vocational education and training. For example, Alfred (2003), Calder (1993), Clark and Wilson (1991), Flowers (2003), Hanson (1996), Jarvis (1987, 1992), Lee (2003), Pratt (1991, 1993) and Shared (1994) argue that adults live, operate and learn in a social context and environment through which they construct and situate their own understandings consistent with their own world view. Jarvis (1987) suggests that adult learning in the social context is characterised by the different ways a person interacts with the world around them. It

sees a person shaped by a particular sociocultural setting who establishes meaning from their interaction with society as they move in and out of different situations.

Additionally as Taylor (1998) points out, factors such as the cultural and historical context in which learning occurs and the learner's race, class, and gender also affect the learning experience. Jarvis (1987) argues that a person therefore can be seen as intrinsically a person-in-society whose understanding is socially constructed through an ongoing learning process, and who simultaneously influences and is influenced by the environment. In this way adult learning can be construed as a social process constituted by the different ways a person interacts with the world.

Social context can also be thought of more broadly than just people interacting with other people, to include people interacting with other material and non-material elements at different levels in society. Such thinking has been popularised by the social ecological perspectives of Bronfenbrenner (1979) and Martikainen, Barley and Lahelma (2002). These social ecological perspectives take into account the important connection between individual behaviour and the overarching multilayered social system.

According to Bronfenbrenner (1979) and DeBord and Thompson (2004), a social ecological perspective emphasises the reciprocal influences that the environment has on an individual and their behaviour through different systems. These systems include the microsystem, exosystem and macrosystem. The microsystem has direct interpersonal influences in specific settings such as family. The exosystem has influences outside of direct contact such as friends and neighbours. The macrosystem represents broad, interconnected beliefs, attitudes, and social systems such as economics, media, immigration, and public policy decisions. Bronfenbrenner (1979) and Grzywacz and Fuqua (2000) argue that the reciprocal influences of the macrosystem result in norms that simultaneously influence and are influenced by individual behaviour at the micro

level, and illustrates the reciprocal nature of a social ecological system.

Situated Cognition

The importance of the social context to adult learning may also be understood by exploring theories of situated cognition. Lave (1988), Rogoff and Lave (1984) and Scribner and Cole (1981) describe situated cognition as learning that is placed within relevant social contexts. It emerged by contrasting how cognition occurs in real situations with decontextualised studies of learning that, because they were tied to particular experimental situations, gave misleading results. For example, a study reported by Lave (1988) combined traditional testing of skills with ethnographic observations of everyday mathematical practices such as doing grocery shopping. Lave found that adults performed very differently in experimental settings when compared to everyday situations. This phenomenon has also been reported by Murtaugh (1985) who found that that on average, grocery shoppers in America scored 59% correct on calculations in decontextualised tests compared to 98% correct when shopping in a supermarket. Similarly in Brazil, Nunes, Schliemann and Carraher (1993) found that children's ability to perform complex calculations while selling in the streets was not reproduced in school math tests.

Sternberg (1985) and Tennant and Pogson (1995) suggest that the difference between the results people achieve in tests and the way they deal with real life problems may lie in the fact that written test problems are pre-defined and have a single correct answer. They compare this with what they describe is a key skill in adult life: the ability to define a problem and its boundaries and find a solution from different possibilities. They also suggest that the solution found, may not be completely right or wrong.

Additionally, Tusting and Barton (2003) argue that problems in everyday life often have to be resolved without all the necessary information or on the basis of

conflicting pieces of information, and when solutions are implemented feedback in everyday life is often ambiguous. They also suggest that most problems encountered in everyday life are addressed in conjunction with other people and that the problem-solving processes people use in everyday situated activities are different from the decontextualised cognitive skills addressed by tests. Finally, as Evans (2000) points out, the transfer of learning to everyday life is a process of reconstructing ideas from the learning context so that they are appropriate for the target setting. Thus, as Lave and Wenger (1991) suggest, whenever people engage in social practice, learning will inevitably follow.

Brain Science

The importance of the social context to adult learning may also be understood by exploring theories of brain science. Sander and Schiech (2005) explain that early theories in brain science attempted to map different areas of the brain to different thought processes. This led to the notion that the right cortical hemisphere was the location of creativity and the left cortical hemisphere was the location of rational processing. However, as Cohen and Leicester (2000) suggest, many neuroscientists now view the brain as a network of paths that work and recombine in parallel, and that continually develops as people interact with the world around them. This view sees learning as a result of the brain engaging in ongoing interactions with the world, though in a much more complex way, and represents an intrinsically social model of learning. Gee (1992) points out that the interactions between the brain and the world always take place within a socially-constructed context, and draw on social and historical resources.

Activity Theory and Social Constructivism

The important roles that social context and environment play in learning has been emphasised through the ideas of the Soviet psychologist Lev Vygotsky. Tusting

and Barton (2003) suggest that Vygotsky's sociocultural theory is rooted in a social constructivist approach to teaching and learning.

The Soviet school of sociocultural theory examined psychological development in the context of goal-oriented interactions with other people that was mediated by socially relevant tools (Vygotsky, 1962, 1978; Wertsch, 1985, 1991). Vygotsky concluded that higher mental functioning such as thinking, voluntary attention and logical memory, was essentially derived from social interaction with others, such as when two people remember something together by prompting or scaffolding one another to achieve recall (Vygotsky, 1962, 1978; Wertsch, 1985, 1991). In other words, in the absence of social interaction higher mental functioning would not emerge.

The Soviet school of sociocultural theory contrasts with Piaget's (1946) paradigm of cognitive constructivism and emphasises the important role that interaction with other people and cultural artifacts play in learning (Vygotsky, 1962, 1978; Wertsch, 1985, 1991). Material and non-material mediating tools or artifacts play a significant role in the process of social interaction. As Vygotsky (1962, 1978) and Wertsch (1985, 1991) argue, people draw on concepts, tools and technologies to mediate the meanings they construct from using them. This thinking sees cognition distributed both between the people present in the interaction and across the mediating tools that are present in the culture. Vygotsky's sociocultural theory situates interaction with other people that is mediated by cultural artifacts at its very core, rather than focusing on the role of the individual alone in constructing meaning (Vygotsky, 1962, 1978; Wertsch, 1985, 1991). It therefore represents a different understanding to a cognitivist model.

Mediating Artifacts of Human Action and Understanding

Central to a sociocultural framework of learning is the semiotic mediation of human action on both the individual and social planes by symbols and signs of social relevance; material and psychological tools called artifacts that stimulate the meaning-making processes (Bruner, 1985; Bruner, Wood, & Ross, 1976; John-Steiner & Mahn, 1996; Vygotsky, 1962, 1978; Wertsch, 1985, 1991).

As noted by Pearsall (1999), the dictionary sense of the word views artifacts as material objects manufactured by human beings that have been subjected to analysis in different strands of thinking. For example, Guribye (2003) argues that in archaeology and anthropology, artifacts and the variety of overt and covert cultural meanings they convey, have played an important role in the explanation of ancient and contemporary foreign cultures. Cole (1996) suggests that, as a result, artifacts are often seen as tools in a certain material culture:

An artifact is an aspect of the material world that has been modified over the history of its incorporation into goal-directed human action. By virtue of the changes wrought in the process of their creation and use, artifacts are simultaneously ideal (conceptual) and material. (p. 117)

Guribye (2003) argues that when artifacts are viewed as reifications of human action, whose properties and attributes are inscribed in the material and psychological form, they play an important role in sociocultural practices by conveying cultural and historical significance and meaning. Artifacts have also been described by Säljö (1996) as tools that mediate the construction of human understanding that, “metaphorically speaking – stand between the individual and the world” (p. 84). John-Steiner and Mahn (1996) and Vygotsky (1978) argue that there are two types of artifacts: technical and psychological. Technical artifacts are most often rendered as inanimate material tools

such as maps, diagrams, computers and writing instruments. Psychological artifacts include tools such as concepts, language, symbols, mathematics and science. Säljö (1996) suggests that one of the most important psychological artifacts is language, which serves as the, “prime device for rendering the world intelligible and for communicating our intentions to others” (p. 84). Vygotsky in Daniels (1996) describes the difference between psychological and technical artifacts by pointing out that psychological artifacts operate on individual thinking and behaviour whereas material artifacts operate on the object that is being mediated:

The most essential feature distinguishing the psychological tool from the technical tool is that it directs the mind and behaviour whereas the technical tool, which is also inserted as an intermediate link between human activity and the external object, is directed toward producing one or other set of changes in the object itself. (p. 7)

Baber (2003), Guribye (1999), Ivarson (2003), Koschmann (1994, 1996) and Latour (1992, 1996) suggest that artifacts also help people achieve goals that would otherwise be difficult or impossible to attain. For example, language can be recorded by using a pen, a journey can be navigated accurately by using a map, and ideas can be communicated clearly by using language. Ivarson (2003) and Wertsch (1985) extend this thinking by suggesting that artifacts can also be used in different ways by different people to create unique understandings. To illustrate this point Baber (2003) provides the example of a mathematician who, by using a calculator to solve a complex problem, may also discover techniques to solve more challenging problems or look at solving familiar problems in different ways.

Artifacts also facilitate people’s behaviour and their understanding of the world by influencing their perception and cognition; a process described by Säljö (1996) as

mediation. The importance of the mediating function of artifacts has been emphasised by Cole (1996), Guribye (2003), Säljö (1996) and Vygotsky (1978) who argue that this is an inherent and inseparable characteristic of any artifact. Tusting and Barton (2003), Vygotsky (1962, 1978) and Wertsch (1985, 1991) point out that this view is central to a sociocultural and social constructivist theory of teaching and learning, and positions artifacts as important components of the social context in which learning takes place.

Alcock (1972), Baber (2003), Beck (1980), Englebart (1963) and Latour (1992) suggest that the primary mediating role of artifacts is to either extend or augment physical and cognitive abilities. For example, Latour (1992) suggests that artifacts may act as extensions of the physical body by furthering reach and amplifying the force applied to other objects, or by increasing the efficiency with which tasks are performed. However, Baber (2003) argues that artifacts not only extend physical capabilities, but may also expand psychological capacity. For example, a shopping list serves the dual purpose of acting as a reminder of what to buy and a tool for planning the shopping experience. Alcock (1972), Baber (2003) and Sterelny (2005) also suggest that artifacts can help compensate for biological deficiencies by extending and augmenting capability. For example, prosthetics, spectacles and cochlear implants are used by people who experience physical impairments to augment compromised mobility, vision and hearing. The primary mediating role of artifacts to either extend or augment physical and cognitive abilities has been acutely illustrated by Vygostky (1978) who described experiments where people with Parkinson's disease used coloured cards or paper templates to perform tasks they otherwise could not have undertaken.

Non-Human Artifacts

The study of artifacts has focused on the material form manufactured by humans, which is evidenced throughout the literature by Divahran and Ping (2002),

Guribye (1999, 2003), Ivarson (2003), Koschmann (1994, 1996) Postholm, Pettersson, Flem and Gudmundsdottir (2002). Thus the study of artifacts has largely been seen as the study of inert physical objects such as stone axes of early hominids, knives, screw drivers, hammers, doors, door hinges, and most popularly as the study of television, computers, the telephone and the media. Similarly, Latour (1992) describes the representation of artifacts as tools that are delegated human effort by shifting action and responsibility to the non-human. For example, the hinge is delegated the action of opening and closing a door, voicemail the action of answering a telephone, and the crane or forklift delegated the action of lifting heavy objects.

The important link between artifacts and society has been emphasised by Latour's (1996) notion of the non-human missing masses of society. This notion was originally used to challenge some of the assumptions sociologists held about the social context of machines. Latour (1996) argues that sociology is not the science of human beings alone and that it can, "welcome crowds of nonhumans with open arms" (p. viii). According to Latour (1996) humans and their interrelationships are insufficient to balance the accounts that sociologists make of society. Latour (1996) argues that physicists claim that there is not enough mass in the universe to account for what cosmologists know about it. Similarly, sociologists are constantly searching for the social links that would lead to a unified understanding of the human social system. He calls these social links the missing masses of society. Latour (1996) suggests therefore, that to balance accounts of society, attention needs to be turned away from humans to non-humans, and argues that the missing masses of society may well lie in the sociology of artifacts. However, non-humans by their virtue of being, may also include those with life and lifelike processes such as animals, which like inanimate artifacts, are

also strongly social and highly moral. Yet the human use of animals as artifacts is conspicuously absent in the literature on artifact use.

Animals as Non-Human Artifacts

History provides evidence of the mediating role that animals may be seen to play in a variety of situations. For example, Zhu et al. (2004) suggest that the use of animal skins for clothing, and their bones and teeth as weapons, influenced the way early humans hunted and survived. In this way animals may be seen as living objects of human goal-directed action. For example, the preconceived goals of warmth and protection may have driven the action of slaying animals for their skin and fur, and fashioning them into objects of clothing. Similarly, the goals of hunting, slaying and survival may have driven the action of fashioning animal teeth and bones into weapons. Similarly, Sunquist and Sunquist (2002) describe that in Egypt around 4,000 years ago, animals were mummified and deified as idols of worship. They also describe that animals in the Middle Ages bore social and cultural significance as familiars to religious disciples that mediated people's communication, social behaviour and relationship with their concept of God. Further, Balcombe (2000), Coppinger and Coppinger (2001) and Newby (1999) describe that more recently animals have been used to plough fields, shift loads, retrieve the hunt, shepherd the flock and controversially as the subjects of scientific experimentation and vivisection.

Further evidence of the way animals may be seen to function as artifacts can be found in what Wilson (1984) describes as people's pre-occupation with animals and their, "innate tendency to focus on life and lifelike processes," (p. 1) as well as their innate sensitivity and need for other living things arising from a coexistence and relationship with the natural world. Wilson (1984, 1992, 1993) argues that humankind's pre-occupation with animals is reflected in the behaviour of our society,

where in the United States and Canada more people visit zoos than attend sporting events. In America alone there are more than 500 million pets, including 99 million dogs and cats (Newby, 1999; Shepard, 1993; Tiger, 1992). In Australia where the picture is similar, people spend \$4 billion a year on their four million dogs, 2.47 million cats, 8.7 million birds and 12.2 million fish (Dasey, 2003).

However, Malamud (2003) argues that despite this apparent pre-occupation with animals, their status in society can be compared to that of women before feminism. That is to say they are considered by the dominant group as subordinate and are defined in generic and reductive terms. Malamud (2003) suggests that to overcome this paradigm, society's anthropocentric perspective of animals must be decentred to uncover their true reality. He argues that this can be achieved by understanding the difference between what animals are, and how people think of them as a constellation of ideas such as noble, intelligent, cruel and caring.

Additionally, Malamud (2003) argues that the \$30 billion a year American pet industry may provide evidence of people's consciousness of animals and their closeness with them, and at the same time, may also highlight their commodification. For example, the fashion vogue for animal print clothing may reflect an appreciation and connection with dogs and cats. Conversely, it may simply represent a cheap, irreverent appropriation of their biological beauty. Similarly, animal films may indicate an interest in seeing them in an intellectual and meaningful manner. On the other hand, they may represent the co-opting of animals for the sake of infotainment. Malamud (2003) points out that these issues are now being explored by adding the perspectives of sociology, cultural studies, literature, philosophy, history, art history and the history of science in an attempt to determine where animals are located in society.

Burt (2001) also describes contradictions in where animals are located in society. According to Burt (2001), the celebration of animals that is seen through their portrayal in nature films, the formation of animal welfare groups, and in society's concern for the destruction in global biodiversity, is inconsistent with its sanctioning of the large-scale destruction of animal life. This inconsistency gives rise to what he describes as the empathy—exploitation conflict. As Burt (2001) explains, this conflict combines a preoccupation with the humane alongside codes that sanction animal killing and experimentation in areas outside the public view. Burt (2001) argues that to avoid this conflict humankind has chosen to locate animals within a well-organised cultural logic that places them in defined categories such as pets, vermin, threatened species and food.

Burt (2001) also argues that where animals can be seen, they become bearers of morality. In support of this, he cites the scene of animals being driven to the London market as inspirational to the formation of the Royal Society for the Prevention of Cruelty to Animals in 1824. The visualisation of animals has also led to an increase in control over a number of different animal-related domains. For example, Burt (2001) cites the enactment of legislation in England in 1857 to prevent children under 14 years of age visiting abattoirs and witnessing the slaughter of animals. Similarly, Vialles (1994) cites the French reforms of the meat trade in 1806 that led to abattoirs being made architecturally anonymous and relocated from urban centres. He also cites changes to later editions of the *Larousse Gastronomique* where photographs depicting the slaughter of animals were replaced with diagrammatic representations.

The link between the visual and the moral, highlights the power of animal imagery. For example, as well as contributing to an improved framework for society that Burt (2001) suggests, Merritt and Barth (2000) argue that the visual image of

animals has also been instrumental in the development of technologies in the fields of photography and moving film that ironically also enhance their visibility. Similarly, Berger (1980) argues that there is a causal relationship between the increase in animal imagery and the disappearance and extinction of animals, and suggests that animal representation in culture compensates for the increasing absence of animals in daily life.

This discussion points towards the unique relationship and bond that humankind shares with animals, which contrasts with the relationships they share with other non-human artifacts. Exploring this relationship may offer different perspectives on how animals may be seen to function as artifacts in society.

The Animal-Human Bond

Granger and Granger (2003) describe the human-animal bond as a reciprocal relationship that involves love, admiration and trust. Additionally, Sehee (1998) and Trachtman (2003) suggest that animals are seen as easier to get along with than people, and more truthful, sincere and accepting. However, Archer (1997) and Serpell (1991, 2000) argue that even though strong feelings towards companion animals may be an indication of an inadequacy of a person's relationships with other humans, pet ownership is too widespread to be an abnormal response by an individual to their social shortcomings. Archer (1997) argues that there is no evidence to suggest that people with a deficient capacity for human relationships turn to pets as substitutes. In support of this Archer (1997) claims that those adults who are most strongly attached to their dog also have secure attachments in their relationships with other adults; the opposite of what could be expected if attachment to companion animals was a result of a difficulty in forming relationships with other people. However he does acknowledge there are indications of greater attachment to companion animals among people living alone or without children, particularly women.

Attachments to companion animals can be intense. For example, Archer (1997) claims that there is anecdotal evidence to suggest a parallel between the reactions of people losing a companion animal and their reactions to losing a human relationship. Similarly, Granger and Granger (2003) and Trachtman (2003) argue that the dignity and respect for others on which democracies are built are often extended to animals. They therefore call for animal abuse to be viewed as a serious crime alongside child abuse.

An important concept that Archer (1997) and Utlah (2003) argue that impacts on our relationships with animals, is known as neoteny³. This is a concept that is particularly relevant to our relationship with domestic animals since as Newby (1999) explains, they are only allowed to develop to a child-like mental state. Accordingly to Archer (1997) neoteny is most evident when people view their relationships with companion animals as similar to those they have with children and is evidenced by talking to them in “motherese” or baby-talk, and by holding and cuddling them as one would a baby. Archer (1997) also suggests that because people have strong nurturing and parental instincts, they respond to the neotenous characteristics in animals that they find similarly attractive in infants, such as a large forehead, large and low-lying eyes, chubby cheeks, short and thick limbs and clumsy movements.

Animals as Artifacts in Therapy and Education

Heimlich (2001) argues that the importance of animals in enhancing the quality of life has been recognised and documented for several hundred years. This observation points towards the roles animals play in therapeutic and childhood educational settings that may provide further evidence of the way they may be seen to function as artifacts.

³ Neoteny is a concept that describes the persistence of childhood characteristics and qualities through to maturation (Newby, 1999).

For example, Fawcett and Gullone (2001) and Heimlich (2001) argue that as early as the 1960s and the work of Boris Levinson (1969), the use of animals in therapeutic and educational settings has had positive effects in overcoming cognitive, emotional and behavioural disorders in disadvantaged children, and has given rise to the practice known as animal-assisted therapy.

However as Creagan (2002) points out, it is only during the past few decades that researchers have explored the benefits of interacting with animals that suggest it affects people emotionally, physically and psychologically. For example, one of the often cited benefits of interacting with animals is that it can induce relaxation (Anderson, et al., 1992; Archer, 1997; Katcher, et al., 1983; McLaughlin, 2003; Messent, 1983; Serpell, 1990; Soares, 2003). However, the benefits of interacting with animals are not limited to increased feelings of calm. They also include: improved self-esteem (Bardill, 1997); increased energy and physical interaction (Burgess, 1997); reduced tension, depression, vigour and fatigue (Crowley-Robinson, et al., 1996); decreased blood pressure (Katcher, et al., 1983); reduced minor health problems (Serpell, 1991); and increased appetite, responsiveness and mental alertness (Heimlich, 2001). Studies also describe that interacting with animals in therapeutic and childhood education settings can also benefit people's learning processes. These benefits include: cognitive improvement (Heimlich, 2001); improved functioning of children with conduct disorder and attention deficit hyperactivity disorder (Katcher & Wilkins, 1994); increased length and complexity of sentence structures, intelligibility, peer interaction and communication (Anonymous, 2003); improved cognitive development (Kotschal & Ortbauer, 2003); accelerated learning (Katcher & Wilkins, 1994); increased motivation (Goodwin, 1999); improved student achievement (Baker, 1987); improved literacy (Townsend, 2003); enhanced verbal communication (Batson, et al., 1998);

increased attention span (Heimlich, 2001); and increased learning (Miller, et al., 2003),

However it appears that people's interactions with animals do not need to be complex. For example, Anderson et al. (1992) point out that the simple act of petting an animal can lead to a decrease in a person's blood pressure. Similarly, Cukan (2002) claims that people who stutter report feelings of relief when merely stroking a dog . Equally, Fawcett and Gullone (2001), Griffin (2003), Hart, Hart and Bergin (1987), Lockwood (1983) and Rossback and Wilson (1992) argue that even the mere observation of animals can result in reduced stress and increased positive mood.

Cukan (2002) suggests that almost any stressful or traumatic situation can be eased when a pet is present. Creagan (2002) argues that interacting with animals also decreases loneliness and stimulates conversation, and gives attention to people who might otherwise not receive as much. Similarly, Cukan (2002) claims that people find talking to animals less stressful than talking to other people and will often practice a conversation with an animal first before attempting it with a human. Additionally, Fawcett and Gullone (2001) and Roseberry and Rovin (1999) suggest that interacting with animals can reduce withdrawal and avoidance behaviours through their ability to positively predict and instinctively react to positive stimuli. Through these qualities they can therefore provide a source of unconditional social support.

Edney (1992), Katcher and Wilkins (1994), Mallon (1994), Melson (1989) and Netting, Wilson and New (1987) further suggest that interacting with animals may be responsible for the development of interactive and socially appropriate behaviours. One explanation for this is suggested by Ascione (1992), Bryant (1985), Fawcett and Gullone (2001), Griffin (2003), Paul (2000) and Poresky (1996) who argue that a positive empathy and disposition towards animals generalises towards humans and that a positive disposition towards animals can be used as a predictor of people's disposition

towards others. Ross (1999) argues that caring for animals is the first step towards developing a humane ethic and a concern for other people arising from the opportunity to love and be loved. Bridges (1997) extends this thinking by suggesting that the concern for other people fostered by caring for animals, may also play a protective role against the development of externalising behaviour problems.

Additionally, animals are often perceived as accepting and non-judgemental. For example, Cuckan (2002) and Fawcett and Gullone (2001) suggest that they promote a safe climate and provide an opportunity for emotional investment that is free of negative evaluation and not subject to feelings of rejection. They refer to this concept as unconditional positive regard. Unconditional positive regard is particularly relevant in extremes of inhibition or shyness. Fawcett and Gullone (2001) suggest that animals are often not perceived as being psychologically threatening due to their inability to criticise or make judgements. They argue that as a result, animals may increase a person's self-efficacy and trust in others, and reduce their feelings of rejection and inadequacy. Fawcett and Gullone (2001) conclude that animal assisted therapy may interrupt the chain of reaction of failures by providing children with an opportunity to learn in an environment that is free of negative evaluation. Along with Lockwood (1983) they further suggest that humans who are associated with animals are perceived to be less threatening and more friendly. They argue that this suggests incorporating animals into an intervention programme is likely to have a positive effect because a therapist in the presence of an animal is less likely to be perceived as having hostile intent.

Additionally, both Fawcett and Gullone (2001) and Levinson (1969) suggest that the emotional spontaneity of animals can work against the over controlled behaviours of children with internalising tendencies. They argue therefore, that the

facilitation role played by animals in social situations could be invaluable in promoting an environment conducive to openness and emotional expression.

However, studies that have reported benefits of interacting with animals have not been without criticism. For example, DeGrave (1999), Draper (1990), Heimlich (2001), Rathmann (1999) and Roseberry and Rovin (1999) argue that most studies are either flawed or consist of empirically unsophisticated work based on anecdotal evidence, are largely descriptive and lacking in scientific methodology and empirical evaluation of outcomes. According to Fawcett and Gullone (2001) this may be as a result of a generalised bias against the value of interacting with animals. Beck and Katcher (1984) concluded that the available literature on pet therapy consists almost exclusively of descriptive or hypothesis-generating studies. They were able to find only six experimental studies on the therapeutic value of pets in which control groups were used, of which only one showed a measurable benefit. Similarly, Garrity and Stallone (1998) reviewed the studies on the impact of animals on people's quality of life and identified more than 100 papers published between 1990 and 1995. Reported in Table 2 are the 25 papers they found after they had excluded those dealing with child development, and animals in therapy and bereavement. Of these 25, they found only five that were experimental. Reported at Appendix A is the researcher's own review of papers that was undertaken to inform the design and framework for the methodology used in this study.

One study of significance to this research was reported by Bernadette Nicholls (2006), a secondary school teacher of English, Literacy and Geography at St Monica's College in Epping, a suburb of Melbourne in the state of Victoria. Nicholls explored the effects of a trained educational therapy dog on student wellbeing, relationships and learning in her class of Year 7 students as part of her Masters of Education. Nicholls'

Table 2

Summary of Papers on Animals and Quality of Life 1990-1995

Type of paper	Type of well-being studied	Outcomes ⁴
4—Descriptive	11—Psychological	16—Positive
16—Correlational	6—Behavioural	11—Negative
5—Experimental	7—Physical/physiological	
	2—Social	

dog, an English Springer Spaniel named Gus, began training for his role in the classroom at 12 weeks of age. Gus accompanied Nicholls in the classroom for two and a half years, and was allowed to wander between chairs, stretch out on a mat under the whiteboard or sleep next to students. Nicholls (2006) reported that students initially thought Gus would be a distraction, yet she found that he helped increase cognition and concentration. One student reported that Gus helped keep attention in the classroom rather than out the window, and drew students back to the present (Leung, 2006; Nicholls, 2006). Another student likened the presence of Gus to playing a radio while studying (Leung, 2006).

In her research, Nicholls (2006) described Gus' presence in the classroom as a change catalyst and reported that he provided an anchor and stability for students by the way he, "brings the class together, and we have something in common. I see this class like family. We look out for each other" (p. 20). Nicholls' (2006) also reported that her

⁴ Some papers reported both positive and negative outcomes.

Year 7 students knew the expected ways of engaging with Gus, such as lying quietly near a student when Nicholls was teaching. They also knew when it was appropriate to engage with him, such as when he was freely wandering when students were working independently or in groups. She also reported that through their own initiative, her students constructed ground rules for taking personal responsibility for Gus' welfare and needs, such as wiping his mouth after drinking, disciplining such as a firm "no" when he wandered out of the classroom door, and reported that students felt proud and special when Gus responded to their obedience commands.

Nicholls (B. Nicholls, personal communication, 5 April, 2006) explained in a personal email communication, that it was a focus on the students' own processes of learning rather than on the teacher-centred curriculum that provided a strong influence on her research:

One of my great frustrations as an educator is the focus on curriculum first and foremost, forgetting about the students in the process. This has been a driving force for attempting this research. My focus has been on the students and their needs within the classroom environment. I have drawn on resiliency research and what makes a student resilient in the school context as well as the research on student engagement. My approach is one of, if the students' well-being (belonging, connection, being known, feeling safe etc..) is being addressed the students are then more predisposed to learn.

Nicholls (B. Nicholls, personal communication, 5 April, 2006) also explained that her research was rooted in the interpretive, constructivist school, employed a phenomenological approach, and used a range of data collection techniques that included focus group interviews, surveys of students, participatory observations and peer debriefings with her university supervisors and academic and administrative staff

at the school where she taught. Nicholls (2006) reported that a significant impact of having Gus in the classroom was the motivation of children to come to class and stated that a challenge for her as a teacher was, “making kids happy to come to school.”

Dogs as Mediating Artifacts

Watson (1998) argues that the range of animals used in therapeutic and childhood educational settings includes mice, guinea pigs, birds, fish, horses, cats and dogs, farm animals, wild animals, domestic animals, and exotic animals. She notes however, that dogs are by far the most common. The roles they play in these settings appear to indicate the unique way that dogs rather than any other domestic animal may be seen to function as mediating artifacts in society.

According to Newby (2001) only seven species in the animal kingdom have been selected for deliberate physiological and psychological modification over the history of their incorporation into goal-directed human action through the process of domestication: horses, goats, sheep, cattle, dogs, cats and pigs. However as Coppinger (2001), Messent and Serpell (1981), Newby (1999), Paxton (1994), Price (2002), Utlah (2003), Wade (2002) and Zawistowski (2003) suggest, the dog enjoys a rich symbiotic co-evolution and relationship with humans that is unequalled.

The domestication of dogs over a period of 135,000 years has produced 331 different breeds that share diverse physical and behavioural characteristics, and are used for a variety of purposes such as hunting, scenting, retrieval, working assistant,

companion and as *chien de fantaisie*⁵ (Coile, 2002; Coppinger & Coppinger, 2001; Fédération Cynologique Internationale, 2004; Hare, Brown, Williamson, & Tomasello, 2002; Merritt & Barth, 2000; Newby, 2001; Provet, 2003; Wade, 2002).

Another indication of the way dogs may be seen to function as mediating artifacts is suggested by Burt (2001) and Merritt and Barth (2000) who describe dogs as an embodiment of the culture and history of society that straddles the psychological and physical domains. They are present in the physical form, and in the concepts and ideas portrayed through films such as *101 Dalmatians* (Peet & Smith, 1961), religious icons such as Anubis, artworks such as Pierre-Auguste Renoir's *Girl with a Dog*, and morality⁶ such as the Royal Society for the Prevention of Cruelty to Animals. Additionally, Sachs (2003) argues that in a fragmented and disconnected society, dogs are often treated as family members and human surrogates. She also suggests that an increasing number of people claim to receive greater support from their dogs than their spouses or parents, and claims this places a greater burden on dogs to provide emotional

⁵ The term *chien de fantaisie* describes the dog's influence amongst the middle-class during the mid to late nineteenth century in Europe where dog ownership was predominantly the realm of the upper ruling-class. Dogs allowed middle-class families to emulate the rich, and compensated for a lack of good breeding. They also provided amusement, and relieved the monotony and pressures of everyday living (Merritt & Barth, 2000).

⁶ Society's treatment of dogs and other animals can be seen as a reification of its morality as suggested by the direct connections between animal abuse and domestic violence where, "In violent homes, when animals are abused, people are at risk." (British Columbia Society for the Prevention of Cruelty to Animals, 2004, p. 1).

and psychological support. Similarly, Mantell (2003) argues that the rapid growth in the dog population can be linked to the boom in television use, which sociologists believe is due to people's increasing difficulty in making contact with others.

A further indication of the way dogs may be seen to function as mediating artifacts in society is suggested by Belkin (2001) and Hendrickson (1999). They describe an emerging trend to allow dogs in the workplace, as companies strive to develop innovative ways of attracting and retaining good employees. Hendrickson (1999) explains that the trend is still in its infancy, yet a small number of companies recognise the contribution a proactive pet policy can make to providing a strong incentive for employees to remain with the one company. Hendrickson (1999) suggests that dogs bring a sense of humanness and informality into the workplace, ease tension and stress, and keep people focused by easing concerns about their pet's safety when it is home alone⁷. Conversely, Belkin (2001) and Hendrickson (1999) suggest that dogs can also prove a distraction by lowering productivity, attacking and shredding documents, exhibiting a hatred of uniformed delivery personnel, interrupting phone calls and wanting to play.

Modes of Using Dogs as Artifacts

A further review of the literature suggests that dogs can be seen to function as mediating artifacts in three distinct modes: functional efficiency, empowerment and social enhancement. In the functional efficiency mode they may be seen to assist the

⁷ According to a study by the American Animal Hospital Association seventy-five percent of owners feel guilty about leaving their companion animals at home when they go to work (Belkin, 2001).

achievement of human goals. In the empowerment mode they may be seen to overcome limitations. In the social enhancement mode they may be seen to extend social functioning.

Functional Efficiency Mode

Dogs such as working dogs and cattle dogs may be seen to function as artifacts in the functional efficiency mode by the way they enable the achievement of more with greater human efficiency. It is one of the more recognisable ways that dogs may be seen to function as artifacts. Latour (1992) uses the term delegated action to describe a key characteristic of artifacts. According to Latour (1992) delegated action describes the displacement or shifting of human action to the non-human in order to achieve a preconceived outcome. The answering machine serves as a contemporary example of delegated human action, where the task of answering the telephone and recording a message is shifted from the human to the non-human. Similarly, human action may be seen to be shifted or transposed to dogs. For example, the goal of herding of sheep and cattle is made quicker with less effort on the farmer's part when a dog is engaged to do the herding. Therefore, they can be seen to assist the achievement more with less effort and greater efficiency through delegated human effort.

The functional efficiency mode also sees human effort delegated to dogs in order to achieve goals that would otherwise be dangerous or impossible to achieve. For example, according to Scoville (2005) service dogs such as police dogs, provide greater security and protection, and assist in performing tasks with greater efficiency than can be achieved by humans alone. When police dogs are sent into life threatening situations to apprehend criminals, they are delegated the human actions of security and protection. Scoville (2005) also describes how service dogs engaged in law enforcement, security and rescue operations are delegated the actions of detecting bombs, drugs and cadavers

that would otherwise be difficult with the limited human olfactory senses. Their engagement in these operations also reduces the risk to human safety.

Empowerment Mode

Dogs may be seen to function as artifacts in the empowerment mode by the important role they play in overcoming a range of limitations that accompany some conditions found in particular groups within broader populations. According to Modlin (2000) dogs in the service of the people with limited mobility, perform a variety of delegated tasks to overcome limitations by retrieving dropped items, carrying packages, providing balance and pulling wheelchairs. For example, Modlin (2000) cites the use of dogs by people with visual impairments to overcome their limitations. This allows them to function with greater independence, mobility and increased physical capacity. As a result, their understanding of the world is conceivably influenced by the way dogs may be seen to function as mediating artifacts.

The ways that dogs may be seen to function as artifacts in therapy situations, which were discussed earlier, also suggests the mediating influences that they have on the people's ability to operate in the world. It is a function that is further suggested by their role in assisting people overcome behavioural and psychological difficulties. For example in one study by Katcher and Wilkins (1994) children diagnosed with conduct disorder were reported to demonstrate fewer aggressive behaviours after engaging with dogs than those who did not. Similarly Heimlich (2001) claims that dogs used in behavioural programmes have contributed to positive changes in aggressiveness, irresponsibility, social withdrawal and anxiousness amongst people diagnosed with severe to moderate mental health difficulties.

Dogs may also be seen to function as artifacts in the empowerment mode by the role they play in mediating patient recovery. For example, studies by Friedmann,

Katcher, Lynch and Thomas (1980) and Friedman Thomas (1995) claim that coronary patients who owned dogs were more than eight times more likely to be alive one year later than non-pet owners. According to Anderson, Reid and Jennings (1992) pet ownership has also been associated with a reduced risk of coronary heart disease amongst people attending cardiovascular disease screening.

Dogs may also be seen to function as artifacts in the empowerment mode by the role they play in the rehabilitation of criminals. For example, Watson (1998) reports that at the Lexington Correctional Centre in Canada there are approximately 20 inmates involved in *The Friends for Folks* programme where dogs are trained by inmates to assist the elderly and people experiencing physical and intellectual impairments. According to Watson (1998), the dogs are trained to perform a range of tasks that include retrieving dropped items and alerting owners when the telephone or doorbell rings. Watson (1998) claims that the mediating role of dogs in prisons has: reduced feelings of isolation and frustration resulting from incarceration; provided something for the inmates to care for; provided lessons on care and responsibilities for life; provided job skills; increased self-esteem and decreased levels of depression; increased communication amongst inmates; created a positive emotional climate within the institution; assisted inmates in getting in touch with their feelings; and provided opportunities for inmates to feel better about themselves and their ability to accomplish goals.

Social Enhancement Mode

Dogs may be seen to function as artifacts in the social enhancement mode in two distinct ways: to mediate social functioning; and to mediate learning. The role of dogs in mediating social functioning includes: their representation in metaphors, storybooks, film, television and cartoons; the way they foster the establishment of social norms and

behaviours; and the way they influence perception. The role of dogs in mediating learning includes: their active engagement in curricula; the way they help establish a positive emotional climate; and the way they foster critical reflection for transformative learning.

Mediating Social Functioning Through Representation

The representation of dogs may be seen to mediate social functioning in a variety of everyday situations. In advertising and marketing campaigns for toilet paper and tissues the representation of young dogs may be seen to convey ideas of softness and gentleness that are aimed at making the product more appealing. In this way as Burt suggests (2001) the representation of young dogs in metaphors and signs may be seen to convey human ideas.

Similarly, through their functioning in metaphors, storybooks, cartoons and film dogs, like other animals, may be seen to speak on behalf of humans, talk to children and convey messages in a non-threatening manner and with greater acceptance. As McKay (2001) suggests the way dogs feature as central characters in *Aesop's Fables* (Aesop, 1989), *The Plague Dogs* (Adams, 1977) and *Investigations of a Dog* (Kafka, 1977), they may be seen to voice human ideas and concerns and act as proxies in the sense that they are speaking for humans. The 1999 movie adaptation of George Orwell's *Animal Farm* (Orwell, 1945; Orwell, Jones, & Burke, 1999) uses a dog to narrate a story in which a variety of animals are used to explore complex themes that include: the corruption of Socialist ideas in the Soviet Union; the societal tendency toward class stratification, the danger of a naïve working class; and the abuse of language as instrumental to the abuse of power (Phillips, 2007). In the films *101 Dalmatians* (Peet & Smith, 1961), *Space Buddies* (Peet & Smith, 2009), *Bolt* (Fogelman & Williams, 2008) and *Beverly Hills Chihuahua* (LaBianco & Bushell, 2008), the representation of

dogs may be seen to speak on behalf of humans by conveying a range of human ideas in an attempt to make the messages more attractive and easier to understand. In these films dogs are endowed with human-like characteristics through a process that Burt (2001) describes as anthropomorphism. They are represented with the ability to speak, cry, laugh, sing, solve complex problems, show concern for family, live in urbanised environments, trade in commodities, and marry into spousal relationships. According to Burt (2001) and Marvin (2001) through the process of anthropomorphism the representation of dogs is overlaid with human characteristics and so they become the bearers of human concerns.

Dogs represented in language are used to convey particular meanings. Expressions such as, “going to the dogs,” and, “a dog’s life,” convey meanings of hardship with subtle yet important inferential differences (Ammer, 1992). For example, the idiom, “going to the dogs,” conveys meaning of deterioration towards hardship or to come to a bad end, whereas the phrase, “a dog’s life,” conveys meaning of a difficult existence characterised by constant hardship (Ammer, 1992). As Jones (1943) and Roberts (1944) suggest, the use of idiom conveys strong emotional content in a compact form that is shared within a common culture. According to Jones (1943) and Roberts (1944) the shared emotional content and meaning of such idioms is often lost for a person of non-English speaking background. In this way, the representation of dogs in language may be seen to mediate social functioning by fostering a shared understanding within a common culture and by conveying detailed or complex meaning in a compact form.

Mediating Social Functioning Through the Establishment of Social Norms

The enculturation of dogs may be seen to mediate social functioning by fostering normative social behaviour regarding the way people interact with them in a

manner similar to the way that social norms are created around the use of material artifacts. For example Baber (2003) argues that when the use of an artifact is learned, the accumulated knowledge and attitudes of the culture that the artifact represents are also passed on. For example, Baber (2003) cites how a glass implies a socially and culturally determined way of being used including the cultural protocols that influence how it should be held, the level to which it should be filled, and how it should be drunk from. Similarly Guribye (1999) cites the way that the telephone implies rules and norms surrounding its use such as how to open and close a conversation and how quickly it should be answered.

Similar social norms may be seen to be fostered when people interact with dogs, and may be seen to mediate social functioning. For example Marvin (2001) claims that in the hunting world where the hound has an elite image, dogs are referred to as hounds and not dogs. By referring to them as dogs outsiders are considered ignorant or insulting. Similar rules are established by kennel clubs regarding the showing of dogs. These rules guide the acceptable behaviour of people during instruction and show including being punctual, keeping dogs on leads at all times, not arguing with or correcting others, and spectators staying off the field on the perimeter of the training ground (Dinsey, 2004). Ahmed (2007) and Kin (2005) suggest that in some non-western cultures normative behaviour is established through religious beliefs where the unacceptability of touching dogs can lead to people going out of their way to avoid close proximity with them. Normative behaviour may also be seen to be fostered informally when people interact with dogs. For example McLaughlin (2003) suggests that people are more likely to approach a stranger walking a dog in the street and engage in conversation with them than they are a stranger walking alone.

Dogs may also be seen to mediate social functioning in broader society by creating rules and laws governing people's interaction with them. Paxton (1994) points out that in urban Australia these laws focus on: control through ownership registration and promoting on-leash behaviour by restricting access to some areas for off-lead dogs; health and welfare of dogs; and population control through desexing and regulating the supply of pups. Paxton (1994) suggests that these laws aim to establish responsible dog ownership as desirable normative behaviour.

Walker (2003) describes that in Australia, the social norm that regards dining at restaurants with dogs as undesirable is being challenged by people who wish to include their dogs. This practice is common in Europe and North America, however it is less frequent in Australia, which suggests the way the enculturation of dogs in different cultures may be seen to mediate social functioning. Similarly body corporate by-laws prohibit the keeping of dogs in apartments in Australia ("The Body Corporate and Community Management Act," 1997), yet in the United States dogs are often seen as important part of the urban American culture amongst apartment-dwellers as depicted in Catherine Schine's novel, *The New Yorkers* (Schine, 2007).

Mediating Social Functioning Through Perception

Dogs may be seen to mediate social functioning by the way people's disposition towards dogs and their interaction with them, provide visual and emotional clues regarding trustworthiness, social attractiveness and social status. For example, Merritt and Barth (2000) state that amongst the middle class in the nineteenth century, dogs were used to emulate the privileged status of the upper class in an attempt to increase people's social attractiveness and to compensate for a lack of good breeding. This parallels McLaughlin (2003) who argues that when walking a dog people tend to make more eye contact and have more people interact with them. Similarly Griffin (2003) and

Lockwood (1983) claim that when shown photographs of people with dogs and other animals, and photographs of people without, people engaged with dogs and other animals are perceived by others to be happier, friendlier and less threatening than those without. Furthermore Hart, Hart and Bergin (1987) and Lockwood (1983) suggest that the presence of a dog also increases people's social interaction and perceived social attractiveness.

Several authors (Ascione, 1992; Bryant, 1985; Paul, 2000; Poresky, 1996) claim that a positive disposition towards dogs and other animals is a good predictor of a positive disposition towards other people. They suggest that people who are seen to care for dogs are also seen to care more for other people than those who do not. Similarly, Ascione (2001), Johnson (2001) and McIntosh (2001) suggest that there is a direct correlation between the abuse of animals and other forms of family and domestic violence. The findings further suggest that where one exists the other is also likely to exist (British Columbia Society for the Prevention of Cruelty to Animals, 2004). Johnson (2002) and Lockwood and Church (1996) explain that law enforcement agencies are therefore using people's treatment of animals as a barometer of social behaviour in identifying potential criminal activity. Similarly, the Australian Royal Society for the Prevention of Cruelty to Animals, the Queensland Police Service, and New South Wales Police Service are also examining animal abuse in their investigation of potential family and domestic violence cases (Cole, 2005; Lawrence, 2005; Passmore, 2004). However as Ascione (2001) and McIntosh (2001) point out notwithstanding the links between animal abuse and domestic violence, cruelty to animals is a significant form of aggressive and antisocial behaviour in itself.

These suggestions imply that dogs may be seen to mediate social functioning by providing a barometer for acceptable social behaviour and by providing visual and

emotional clues regarding trustworthiness, social attractiveness, social status and concern for others. These suggestions may also be seen to lend support to the popular social axiom of trusting a dog's sense.

Mediating Learning

The way that dogs may be seen to mediate learning is suggested by their structured inclusion in curricula and lessons in schools and universities. For example, Goodwin (1999) suggests that dogs can be included in curricula to teach a variety of subjects including: social studies where different cultures can be studied through the contributions of dogs in history; mathematics where dog populations and physical measurements can be used to learn about mathematical concepts and calculations; and health where the importance of a varied diet and health care can be explored through caring for an dog. Goodwin (1999) also suggests that dogs can be used to achieve nurture objectives by incorporating a class pet to care for, which teaches children responsibility by feeding, cleaning, walking, watering and monitoring the health of the animal. Fawcett and Gullone (2001) suggest it may also increases emotional and social intelligence through compassion and caring for another life that generalises to the caring for other people. In a university setting Hu (2004) describes the active inclusion of a dog as part of the curriculum to teach psychology students about sensation and perception, classical and operant condition, and intelligence.

The way that dogs may be seen to mediate learning is also suggested by the way they help foster a positive emotional climate that is free from negative feedback. For example, *Reading with Rover*, *Paws to Read* and *Reading Assistance Education Dogs* are formal programmes that employ dogs to assist children improve literacy and reading skills. In one study reported by Townsend (2003), once or twice a week children spent about an hour sitting alone with a visiting dog as they practiced reading out load to it.

Townsend (2003) claims that children reported feeling free from negative evaluation and experienced the benefits of unconditional positive regard offered by the dog. As a result the children became less self-conscious and more confident about reading out loud. Thus as Fawcett and Gullone (2001) and Townsend (2003) suggest having a dog around may contribute to the creation of a positive climate that is pleasurable, less anxious or stressful and one that is not subject to feelings of rejection. The presence of a dog in the classroom has also been linked to reduced negative social behaviours such as peer conflict, aggression and out-of-seat behaviour (National Society for Humane and Environmental Education, 2005).

The way that dogs may be seen to mediate learning is also suggested by the way they foster critical reflection and transformative learning. Kolb (1984) and Mezirow (2000) argue that critical reflection is an essential element in two contemporary models of adult learning: experiential learning and transformative learning. According to Kolb (1984) experiential learning is represented as a cycle requiring resolution of four conflicting modes of adaptation to the world: concrete experience, reflective observation, abstract conceptualisation and active experimentation. Baumgartner (2003) and Mezirow (2000) explain that transformative learning emphasises reflection on previously held assumptions about the world as a result of life experiences, such as those with dogs that change how people know and experience the world.

Dogs are an important part of many people's lives and as Taylor (1998) points out it is life that provides the material for critical reflection which is central to the transformative learning process. Cranton (2002) suggests that people can examine critical incidents, such as the loss of a dog or being attacked by one, to reveal their assumptions that may help develop new understandings of self and others, and one's own world view. For example, after the death of his dog Marley, Pennsylvanian journalist John

Grogan (2006) wrote the following personal reflection that illustrates the kind of self-understanding that can be gained through critical reflection on life experiences with dogs:

What I really wanted to say was how this animal had touched our souls and taught us some of the most important lessons of our lives. “A person can learn a lot from a dog, even a loopy one like ours,” I wrote. “Marley taught me about living each day with unbridled exuberance and joy, about seizing the moment and following your heart. He taught me to appreciate the simple things – a walk in the woods, a fresh snowfall, a nap in a shaft of winter sunlight. And as he grew old and achy, he taught me about optimism in the face of adversity. Mostly he taught me about friendship and selflessness and, above all else, unwavering loyalty.” It was an amazing concept that I was only now, in the wake of his death, fully absorbing: Marley as mentor. As teacher and role model. Was it possible for a dog to point humans to the things that really mattered in life? I believed it was. Loyalty. Courage. Devotion. Simplicity. Joy. And the things that did not matter too...It was really quite simple, and yet we humans, so much wiser and more sophisticated, have always had trouble figuring out what really counts and what does not. As I wrote that farewell column to Marley, I realised it was all right there in front of us, if only we opened our eyes. Sometimes it took a dog with bad breath, worse manner, and pure intentions to help us see. (pp. 279-280).

Books such as *Marley and Me* (Grogan, 2006), *Philosopher's Dog* (Gaita, 2002) and *Dogs Never Lie About Love* (Masson, 1998) convey critical reflections on the authors' experiences with their companion animals and the life lessons that each learned as a result. Through critical reflection on experiences with them, dogs are a reminder of

what is important in life and at the same time may help reveal previously hidden understandings of oneself.

Summary

This chapter examined the body of literature surrounding the context within which the research is located and provided support for the ways that dogs may be seen to function as artifacts that mediate people's understanding of the world by increasing functional efficiency, empowering people to overcome limitations, and enhancing social functioning and learning. Dogs may also play an important role in a sociocultural framework for learning by functioning as artifacts that mediate human action on both the individual and social planes in material and psychological ways. In doing so they may help bridge the divide between teachers and their students by levelling the imbalance between assessable outcomes and people's learning processes, which is characteristic of contemporary models of teaching and learning that feature in Australian vocational education and training settings.

The following chapter will draw from the literature to construct a framework for the research methodology that was employed in this study. It will also provide a detailed procedure for conducting the research, a description of the data collection tools and methods used, and a description of the techniques and methods employed to analyse the data.

CHAPTER 3: METHODOLOGY

Introduction

Chapter 1 introduced the aims of this research and highlighted two questions that it seeks to answer: In what ways do people use dogs as mediating artifacts in their meaning-making processes; and what are the effects of dogs in mediating individual and group learning processes?

Chapter 2 examined the body of literature surrounding the context within which the research is located and explored the vocational education and training sector in Australia as an example of contemporary models of teaching and learning. This view of adult learning was contrasted with the social constructivist framework that emerged from the Soviet school of sociocultural theory, central to which is the concept of artifacts that mediate human understanding. Finally several ways that dogs may be seen to function as artifacts in society were examined to provide a framework on which to scaffold thinking in answering the research questions.

This chapter will draw from the literature to construct a framework for the research methodology that was employed in this study. It will also provide a detailed procedure for conducting the research, a description of the data collection tools and methods used, and a description of the techniques and methods employed to analyse the data.

Research Framework

This study adopted a phenomenological perspective that Trochim and Donnelly (2007) suggest focuses on the participants' subjective experiences and their interpretations of these experiences to reveal how they viewed and understood the world. Similarly, Holloway (1997) describes phenomenology as a philosophy, rather than a method, that explores people's, "lived experience starting with their own

reflections” (p. 104). She suggests that meanings are found through the data that demonstrate characteristics of a phenomena being studied, and focus on cognitive and affective phenomena such as how people think and feel. This study sought to understand the phenomena of how people thought and felt about the influence of dogs in mediating their learning processes. It also sought to identify and understand through people’s lived experiences, phenomena that emerged from the data that were not identified beforehand.

Rubin and Babbie (2007) suggest that one form of phenomenological qualitative research is ethnography, which emphasises, “observation in natural settings and focuses on providing detailed, accurate descriptions of the way people in a particular culture live and they way they interpret the meanings of things” (p. 218). This research used an ethnographic approach as suggested by Anderson and Arsenault (2001) and Trochim and Donnelly (2007), and focused on the culture formed by the students, teachers and dogs in a naturalistic setting constituted by the classroom. Kincheloe (2003) argues that there is no clear line separating ethnography from phenomenology, and that ethnographic research can be phenomenological in its orientation.

This research was based on the epistemological view suggested by Saral (1976) that there was no absolute reality or universality in the way people perceived or thought about dogs as mediating artifacts, and that each person’s world view was influenced by their underlying assumptions. This study adopted both an etic and emic perspective. The meaning of dogs as artifacts was explored within the culture constituted by the classroom to establish concepts and understandings shared by participants to provide an etic perspective, as suggested by Bayer, Brisbane, Ramirez and Epstein (1998). Those meanings were also explored across the culture to examine the differences amongst participants and to reveal the emics of the phenomenon. This was achieved by the

researcher becoming immersed in the culture as an observer-as-participant, sharing indirectly in the environment being studied, and recording extensive field notes through observations and dialogue discussions, as suggested by Atkinson and Hammersley (1994) and Goetz and LeCompte (1981).

Byrne (2001) suggests that methods used in phenomenological research include inductive and qualitative methods such as grounded theory. This research used grounded theory in ways suggested by Goetz and LeCompte (1981) to develop understandings of the phenomenon through the emic and etic perspectives generated from the data collected. According to Charmaz (2006), Glaser and Strauss (1967), Haig (1995), Strauss and Corbin (1990) and Trochim and Donnelly (2007), grounded theory is an approach to qualitative research that is rooted in observational and interview data and aims to develop a theory to explain a phenomenon by using an iterative analytical process.

Research Design

The research design engaged 15 adult training course participants and two teachers who interacted with three dogs during a six and a half day vocational education and training course. The course was held in a major regional centre in northern Australia by a private training provider. The course, *TAA40104 Certificate IV in Training and Assessment*, is the entry-level qualification required for practitioners to deliver and assess accredited training. It was chosen as the learning context in this research because it was a representative example of classroom-based training located in the vocational education and training sector that was examined in chapter 2. The research also included the presence of three dogs for the duration of the course, however only one dog was present at any one time. There were no restrictions placed on the dogs, and they were allowed to roam freely around the classroom during the

lessons. Interaction with the dogs was not structured, in order to allow people to choose the ways and times that were most appropriate and meaningful. In other words, this study aimed to reveal emergent, rather than imposing pre-determined methods of using the dogs.

Each technique that was used to gather and analyse data was piloted and the results were analysed to identify how well the data helped answer the research questions. These results suggested improvements that were made to the construction and administration of the data collection tools and helped sharpened the focus of the research design.

Data were collected from different perspectives using different techniques to achieve triangulation and thus increase the trustworthiness of the research, as suggested by Marshall and Rossman (1999). These data were compared with each other to deepen the understanding of the phenomenon and to verify conclusions in the manner described by Marshall and Rossman (1999). The three perspectives from which data were collected were: observations by the researcher as observer-as-participant of students' and teachers' behaviours; students' perspectives of their own and others' behaviours; and one teacher's perspective of her own and her students' behaviours. The six data collection techniques used were: a pre-course questionnaire, critical events technique, repertory grid dialogues; classroom observations; semi-structured interviews; and the researcher's personal journal. The pre-course questionnaire provided background and demographic data that helped build a profile of each participant. A copy of this questionnaire is included at Appendix B. Classroom observations were recorded for the duration of the course using running records. Semi-structured interviews were used to capture perceptions and reflections on people's experiences following critical events

that occurred during the class. George Kelly's (1955) repertory grid technique⁸ enabled people to verbalise how they perceived elements or facets within the classroom domain, and helped construct a picture of their concept models. It also served as a tool for the collection of students' and teachers' narratives at the completion of the course by stimulating dialogue. This technique is described in more detail later in this chapter. Finally, the researcher's journal revealed information about self and method at regular and spontaneous moments during the life of the research.

The naturalistic setting in which this research was conducted was constituted by the classroom, where the researcher spent six and a half days collecting data. Dialogue discussions were conducted at participants' workplaces and homes during the week following the course, where it was not possible to collect data during the course. Interviews and dialogues were recorded onto audio tape and along with observational data from running records, were transcribed onto computer and coded by hand. Emergent coding was used to reveal patterns and themes amongst the data. An iterative process was used to compare and contrast these patterns and themes with temporal

⁸ The repertory grid is as a way of assessing people's system of related meanings and perceptions about the world in which they live (Neimeyer & Neimeyer, 2002; Stewart & Stewart, 1980). It employs an informal interview method during which people are asked to compare and contrast sets of significant elements such as people, events, objects or activities, in order to elicit some important ways they are alike, yet at the same time different from each other (Neimeyer & Neimeyer, 2002; Stewart & Stewart, 1980). These bipolar dimensions of differences represent extremes of a person's construct space that underlie their concept map (Fransella & Bannister, 1977; Neimeyer & Neimeyer, 2002; Stewart & Stewart, 1980).

maps drawn from the observational data, and with the statistical analysis of repertory grid data. This analysis revealed emergent patterns of understandings and contradictions that were used to develop emergent hypotheses and findings to answer the research questions.

Ethical Considerations

The ethical requirements for conducting this research included privacy, confidentiality, security, health and safety. These requirements were met through a formal review process with James Cook University's Animal Research Ethics Review Committee and Human Research Ethics Review Committee. Formal approval was received from both committees (approval numbers A1149 and H2455). The research was conducted according to those requirements.

Participation in the research by students, teachers and the private training provider was voluntary and therefore could be withdrawn at any time. Each participant was requested to complete a consent form prior to the course. They were also assured that their inclusion in this research would not affect any assessments, rankings or reports of academic or learning outcomes, and that no record of their participation in this research would be held in their personnel or academic files by any private training provider or employer.

The pre-course questionnaire was also used to screen participants prior to the scheduled training course to ensure that those people with phobias or health concerns regarding dogs could identify themselves. Permission to continue the research was then sought from these participants. Should any of these participants have declined to continue, the scheduled course would not be included in the research. This ensured that participants were not adversely affected by having to reschedule their attendance at a course at a later date. Only one participant was identified as having health concerns

regarding the presence of dogs, yet granted permission for the research to continue. People with both a positive and negative disposition towards dogs were welcomed to participate. It was expected that that this would provide an understanding of the ways that dogs could be seen to function as mediating artifacts for those people who were not positively disposed towards them, as well as those who were.

Participants were fully briefed on the aims, purpose and methodology of the research prior to the training course. Full details were included in a project information pack that was distributed to participants beforehand, along with a form seeking their informed consent to participate. All participants have been de-identified by name to maintain their privacy and anonymity and have been referred to throughout by pseudonym only. Raw data collected have been treated confidentially, maintained under security and will be destroyed five years after the completion of this study. Privacy has been assured in line with current legislation and information and will not be disclosed to any other party except where required by law. Counselling services through James Cook University were offered for those people who may have been affected by distress through exposure or interaction with the dogs in the classroom, especially accidental distress. Was this to occur, the dog may have been removed from the training situation to protect the safety of participants. However such an occurrence did not manifest itself during the research.

A review of both state and federal government legislation revealed no restrictions preventing dogs from entering the workplace except for food preparation areas and premises where human skin is penetrated. Queensland statutes ("The Body Corporate and Community Management Act," 1997) provided for animals to enter premises with the consent of the landlord. Therefore consent to bring dogs into their workplace was gained from the private training provider. The participating private

training provider was also assured of people's voluntary participation, and was advised that approval had been obtained from James Cook University's Animal Research Ethics Review Committee and Human Research Ethics Review Committee.

A volunteer animal handler from Delta Society Australia Limited accompanied each dog to ensure the safety and well-being of people, and to manage the physical and emotional well-being of the dogs. Only one dog was present at any one time during the course. This presence was limited to periods of no longer than four hours during any one session to reduce the physical and emotional impact on them.

Data Collection Tools

Questionnaire

A short questionnaire was administered prior to the course to gain demographic data and help build a picture of people's backgrounds and profiles. A copy of this questionnaire is included at Appendix B. Demographic information sought from the questionnaire included people's gender, age, their highest level of schooling achieved and the last year they attended school. Information was also sought regarding people's previous positive and negative experiences with animals, childhood and adulthood experiences with animals, fears and health concerns they may have had about dogs being present in the classroom, and expectations about dogs that they may have brought to the research situation. The questionnaire also asked people to self-rate their disposition towards dogs using a five-point Likert scale, ranging from 1 (*don't like dogs*) to 5 (*dogs are a vital part of life*).

Classroom Observations

The research framework for this study emphasised an ethnographic approach based on observations in a naturalistic setting to reveal the meaning of behavioural patterns for the classroom community, as suggested by Anton (1996). According to

Anton (1996), this is best achieved by observing and participating in the classroom's activities, by collecting naturalistic data and by interviewing participants about what is observed. Anton (1996) further suggests that ethnographic observation techniques also enable the researcher to see the classroom as a cultural event where participants establish social norms relevant to that community through spoken and unspoken behaviours.

According to Veale and Piscitelli (1988) there are two main types of observational records: qualitative methods that include anecdotes and running records; and checklists, which are largely quantitative. Anecdotes are recounts of an incident after the event and document a record of the event recalled in the past tense (1988). A running record is a continuous recording of everything that is observed over a period of time and is an open method of observational recording because the researcher does not focus on a particular behaviour.

Wragg (2001) points out that checklists provide quantitative data in the form of frequency counts of observed behaviours against priori categories of action. He argues that a widely used checklist for classroom observation is the Flanders' Interaction Analysis Category system that records the frequency of observed behaviours against ten categories of behaviour. However, Wragg (2001) argues that quantitative methods of classroom observation impose positivist assumptions on what is being observed and do not reveal the whole story of the classroom experience. In designing the research methodology for this study, a quantitative method of classroom observation known as

the VaNTH Observation System⁹ was trialled over ten, four-hour classroom teaching sessions. However, an analysis of data collected revealed limited results in capturing meaningful information that could assist in answering the research questions. For example, because the VaNTH Observation System is used in three-minute cycles, a significant amount of data could not be recorded. It also focused on capturing data about the teaching and learning behaviours in the classroom and did not allow the richness of teacher, student and dog behaviours and interactions to be recorded. This richness of data included eye contact, facial expressions, gestures, vocalisations, emotional responses, and the complex social interactions that occurred simultaneously amongst several people.

Wragg (2001) suggests that the method of classroom observation should suit the purpose of the research. Therefore, the VaNTH Observation System was not used because it did not meet the phenomenological and ethnographic aims of this research, and a qualitative approach to the classroom observations was adopted instead. Such an approach was seen to best suit the purpose of the research by revealing the richness of teacher-student and student-student interactions, the nature of classroom rules, and the

⁹ The VaNTH Observation System (VOS) was developed for use at the VaNTH Engineering Research Center in bioengineering classrooms at Vanderbilt University, the University of Texas at Austin, Northwestern University and the Massachusetts Institute of Technology Division of Health Science and Technology. This instrument is designed to capture the number and duration of faculty-student interactions in a classroom; the engagement of students during a lesson; the lesson content, lesson context, and extenuating circumstances in a classroom; and the global aspects of a class lesson (Cox & Harris, 2003).

interaction between teachers, students and the dogs.

Running records and anecdotes were recorded directly onto a laptop computer using a Microsoft Access database that ensured accuracy by automatically time coding each record. Additionally, this method made it possible to gain extensive observational records that would not have been possible by hand. It also reduced researcher fatigue.

Event Interviews

Anderson and Arsenault (2001) argue that the qualitative interview is an incomparably rich source of data that is widely used in educational research. Kvale (1996) points out that its purpose is to understand the meanings people make of a phenomenon within the context of their world view. Additionally, McNarma (1999) suggests that it is a technique of collecting data that can reveal the story behind a person's experiences, which allows the researcher to explore their deep understandings of a phenomenon.

Qualitative research interviews with participants and teachers were used in this research to capture perceptions and reflections of the classroom experience following critical events, a method known as the critical events technique (2001). In this research, specific instances of classroom behaviour illustrative of the phenomenon being studied were captured and recorded through the running records and anecdotes, and participants were subsequently interviewed about them, as suggested by Wragg (2001). Each interview followed a semi-structured format and was facilitated by the use of an interview guide that was used to navigate the conversation. A copy of this interview guide is included at Appendix C. Each interview started with a broad question using neutral language to elicit unbiased responses, and progressively focussed in more detail on the critical event. For example, during one event interview the questions appeared in the following sequence: "What I want are just your general thoughts about how things

are going at the moment,” “Tell me about this morning,” “What I’m interested in is what happened in the classroom this morning,” “Let’s have a bit of a chat about the dog then, what are your general thoughts on having the dog in the classroom,” and finally, “That’s interesting, okay, let’s talk about that whole event; when it started, when those two dogs walked past the door and Adonis responded quite loudly.”

Repertory Grid Technique

The repertory grid technique uses a semi-structured interview to determine an individual’s perception of a particular subject. McKnight (2000) points out that the repertory grid technique allows a person to verbalise how they perceive elements or facets that, when analysed, can help the researcher construct a picture of their concept model for a particular domain. Norman (2000) argues that compared to other interview techniques, the repertory grid technique minimises the opportunity for respondents’ views to be subject to external bias or influence, because the interviewer has a minimal role in the interview process.

The repertory grid technique sees the interviewee compare and contrast sets of three significant elements such as people, events, objects or activities, and elicits some important way that two of the elements are alike, and yet are different from the third ((Neimeyer & Neimeyer, 2002; Stewart & Stewart, 1980). These bipolar dimensions of difference represent extremes of a person’s construct space that underlie their concept map (Fransella & Bannister, 1977; Neimeyer & Neimeyer, 2002; Stewart & Stewart, 1980). The interviewee is then asked to rate each element on each construct using a five-point Likert scale that builds up into a matrix of elements and constructs. Figure 1 illustrates the final raw repertory grid that is produced. This allows the researcher to get

1	Lady	Adonis	Buddy	Reggie	Sharon	Dan	Andrea	Morgan	Mary	Danni	Borat	Leigh	Wynnie	Mark	Coral	Andy	Wade	Brad	Sam	Alma	5
Drawn Together	2	1	1	5	3	1	1	2	3	2	1	4	1	4	1	3	3	5	2	2	Separated
Communicator	2	1	1	5	4	2	1	1	2	1	2	3	1	2	4	5	3	5	2	3	Loner
Easy Going	2	1	1	5	4	2	2	1	2	1	1	2	1	3	4	5	3	5	2	3	Serious
Immature	5	1	3	5	4	3	4	1	5	4	3	5	1	5	5	5	4	5	3	3	Mature
Warm	4	1	1	5	4	2	1	2	3	1	1	2	2	4	4	5	4	5	3	3	Cold
Guarded Closed	3	5	5	1	1	3	4	5	3	4	4	2	2	2	2	1	2	2	1	2	Open
Fun Happy-Go-Lucky	3	1	1	5	4	3	2	1	2	2	2	3	1	4	5	5	3	3	2	3	Not Flippant
Unstructured	4	1	2	5	4	3	3	3	4	4	3	4	2	4	4	5	4	4	2	3	Judgemental

Figure 1. Sample repertory grid.

close to the person’s functional meaning of the elements and constructs. The reader is encouraged to examine Appendix D, which provides a detailed description of how this technique was used in this research.

Post-course Interviews

The repertory grid technique was also used during this research as a tool for the collection of narratives by serving as a trigger for semi-structured post-course interviews. Spontaneous opportunities to elaborate on personal stories, perceptions and reflections on experiences of the classroom environment were explored during the repertory grid technique. Each interview followed a semi-structured format facilitated by the use of an interview guide that was used to navigate the conversation, rather than following a set of prescriptive questions. A copy of this interview guide is included at Appendix E. These spontaneous semi-structured interviews were used in ways suggested by Kvale (1996) that allowed the researcher to explore people’s learning experiences, their attitudes and perceptions to the inclusion of dogs in the learning environment, and their perception of the teachers and other students.

Researcher's Journal

According to Lincoln and Guba (1985), Maxwell (1996) and Strauss (1987), the researcher's journal is a personal diary that records information about self and method in the form of notes called memos, written by the researcher to him or herself at regular or spontaneous moments during the life of the research. The journal provided data about the researcher as an instrument for the research in the manner suggested by Lincoln and Guba (1985) by revealing the researcher's thinking and analytic processes. The researcher's journal was also used in ways suggested by Maxwell (1996) to develop a greater understanding of the research topic through reflection on readings. In addition to this the researcher's journal was used to expand theoretical ideas by drawing on techniques suggested by Mills (1959), Strauss (1987) and Strauss and Corbin (1990). It took several different forms including brief marginal comments, memos to self, electronic communications, essays, short voice recordings, and handwritten notes and diagrams that conveyed theoretical questions, hypotheses, summaries and reflections. Additionally, it was also used as a method for the development of emerging ideas and theories by facilitating reflection and stimulating analytical insight as suggested by Maxwell (1996) and Strauss and Corbin (1990). Memoing was an important tool that helped make sense of the data in ways suggested by Miles and Huberman (1994) and Strauss and Corbin (1990), by synthesising different pieces into an understandable form and aiding the researcher to move to abstract thinking.

The researcher's journal was used to provide information about methodological decisions and the reasons for making them, which Lincoln and Guba (1985) suggest, improves balance and fairness and increases the trustworthiness of the research. The researcher's journal also contributed to developing an audit trail as a method of establishing the confirmability and trustworthiness of the research. It achieved this in

ways suggested by Lincoln and Guba (1985) by displaying the researcher's cognitive processes, philosophical position, the bases of decisions about the research, and revealing the extent to which the researcher's biases influenced the outcomes.

Environmental Context

Lincoln and Guba (1985) point out that an important element in establishing the trustworthiness of qualitative research is transferability, that is, the extent to which the inferences of the research can be applied to other contexts. They argue that in order to establish transferability the burden of proof lies with the researcher to provide sufficient descriptive data for the reader to make judgements about the applicability of the research to other contexts.

Appendix F answers the question of transferability by providing descriptions of the naturalistic environment within which this research was located, and which the reader is encouraged to examine. These descriptions included: the micro-environment, which was constituted by the classroom; the mezzo-environment, which was constituted by the training provider and the course; and the macro-environment operating outside of the classroom which was constituted by the broader socio-cultural context of the geographic location where the research was conducted.

Research Participants

This research focused on the lived experiences and reflections of two teachers and 15 adult students who interacted with three dogs during the six and a half day *TAA40104 Certificate IV in Training and Assessment* course conducted by Hamptonville Community Training, a training organisation in northern Australia.

Students and Teachers

Participants for this research were drawn from people who responded to advertisements placed in the local newspaper by the training provider, Hamptonville

Community Training, for the *TAA40104 Certificate IV in Training and Assessment*. Teachers were drawn from those employed by Hamptonville Community Training. The research engaged six male and nine female adults who ranged in age from 22 to 63 years of age. They included people from the legal profession, community and education sectors, workers from the defence force and telecommunications industries, mining plant machinery operators, and self-employed business people. All participants were from English-speaking backgrounds, except one participant who had recently migrated from the Czech Republic with his family. Five participants resided in remote rural areas of Australia and travelled to Hamptonville to attend the course. Two students attended the upgrade component of the qualification that was conducted over the first three days of the course. One participant attended three days intermittently due to illness.

The research engaged two teachers. The first was Sam, a 45 year old female who was the main teacher. Alma, a female in her mid-twenties, was the supplementary teacher. Sam taught the class for four and a half days, and was absent when Alma taught the class. Alma taught the class for two days. Both Sam and Alma were employed on contract by Hamptonville Community Training to deliver the *TAA40104 Certificate IV in Training and Assessment*.

Dogs and Their Handlers

Three dogs and their volunteer handlers were recruited for this research through the Delta Society Australia Limited. The Chief Executive Officer was approached and gave his formal endorsement and support for this research by committing the use of volunteer handlers and dogs. No contracts were entered into and no payments either monetary or in kind were made or received for the use of these resources.

Delta Society Australia Limited is a not-for-profit company that has as its mission, to promote and facilitate positive interaction between people and animals.

Among its many programmes is the *Pet Partners Therapy Dogs Programme*. Each week trained volunteers and their accredited dogs, visit hospitals, nursing homes, hostels, rehabilitation centres, mental health units, hospices, and supported care facilities throughout Australia, including Hamptonville (Delta Society Australia Ltd, 2004). Volunteers and their dogs work with rehabilitation specialists, psychologists, physiotherapists, occupational therapists and their patients to achieve the set rehabilitation goals for patients. As a result, The Delta Society Australia has developed protocols for the quality assurance of therapy assistance dogs (Delta Society Australia Ltd, 2004). Volunteers are required to complete induction training and their dogs are assessed for temperament and suitability. They are issued with Delta accreditation upon the successful completion of a weekend training seminar.

The three dogs engaged in this research were Adonis, Lady and Buddy. Adonis was a playful, four-year old Golden Labrador who¹⁰ was accompanied by his handler, Alicia. Lady was a large, well-disciplined four-year old black and tan German Shepherd who was accompanied by her handler, Heather. Buddy was a small, white, three-year old King Charles Spaniel and Poodle cross who was accompanied by his handler, Amanda.

Procedure

Agreement and consent to participate in the research was gained from Hamptonville Community Training and the teachers in November, 2006. The next

¹⁰ Jacobs (2004) points out that there is conflicting guidance within dictionaries and grammatical texts on the use of relative pronouns to refer to animals. However, he suggests that using *who* to refer to nonhuman animals reflects concern for them, extend rights to them, and shows compassion for them that they have previously been denied.

available and most suitable course during which to conduct this research commenced on 6 February 2007. A media release promoting the research and inviting participation was prepared and issued in December, 2006, by James Cook University's Media Liaison Unit. The researcher was subsequently engaged in several radio interviews to promote the research and invite participation.

Suitable dogs and their handlers were selected through consultation with the local coordinator of Delta Australia's *Pet Partners Therapy Dogs Programme* and invited to participate in the research. The researcher met with both the dogs and their handlers prior to the course and explained the purpose of the study, the expectations of dogs and handlers during the course, and answered the handlers' questions and concerns about their participation.

An information pack was prepared that invited people to participate in the research. This pack included a project information sheet that briefly described the research, a copy of the media release promoting the research, an informed consent form, and a pre-course questionnaire. Hamptonville Community Training was unable to provide the researcher with direct access to potential participants prior to the commencement of the course because of privacy legislation. Consequently, the researcher provided a copy of the information pack to Hamptonville Community Training so that it could be sent directly to people when they sought enrolment in the course. The instructions included in the information pack directed potential participants to read the project information sheet, and if they consented to participate, to complete the pre-course questionnaire. People were then directed to return both the pre-course questionnaire and the signed consent form together with their course enrolment registration form to Hamptonville Community Training.

Hamptonville Community Training was requested to follow up the return of the completed consent forms and questionnaires. Hamptonville Community Training was also requested to ask potential participants to contact the researcher so that he could explain the purpose of the research, discuss any concerns regarding their involvement, confirm people's consent to participate, introduce people to at least one of the dogs who would be participating, and confirm completion of the pre-course questionnaire. However, difficulty in contacting potential participants resulted in only one person completing the informed consent form and questionnaire, and contacting the researcher prior to the commencement of the course.

It was important that the consent of all students was gained in order to continue with the research. If one or more people declined to participate in the study, the research would need to be rescheduled for another course at a later date. This was because people attending the course were fee-paying students, many of whom had arranged to take time off work to attend the course and could not easily reschedule their attendance without adverse personal impacts. It was also important that the researcher respect Hamptonville Community Training as a commercial business and that by asking people to reschedule attendance to a later date, may have led to some students cancelling or seeking alternative providers.

The lack of response from potential participants presented the researcher with a significant dilemma. On the one hand there was the decision to continue with the research for the planned course, seek consent from participants at the commencement, and accept the risk of cancelling at the last minute due to one or more people declining to participate. On the other hand there was the decision to reschedule the research for another course at a later date. It was decided to continue with the research for the

planned course, as both options could have potentially resulted in the research being rescheduled and delayed.

At 8.30 am, prior to the commencement of the course on the first day, the researcher addressed the group of students and teachers, and explained the purpose and methodology of the research, what was expected of participants, ethical and safety considerations, and sought the informed consent of people to participate. All 15 students consented to participate in the classroom observation component. Twelve students and one teacher consented to participate in interviews and the repertory grid technique. Thirteen students and one teacher consented to participate in the pre-course questionnaire. Once people's consent had been gained, participants were asked to complete the questionnaire and the researcher invited the first dog and handler into the room and introduced them to the group. One participant joined the course on the second day and was therefore briefed individually on the research and her consent was sought and obtained prior to the commencement of the class. However, this participant did not complete the pre-course questionnaire.

Data collection was conducted from Tuesday, 6 February, 2007 to Thursday 22 February, 2007. Classroom observations and event interviews were conducted at Hamptonville Community Training over the six and a half days of the course between Tuesday, 6 February, 2007 and Thursday, 15 February, 2007. Post-course interviews and repertory grid technique discussions were conducted between Wednesday, 14 February, 2007, and Thursday, 22 February, 2007.

Adonis, and his handler Alicia, attended the morning lessons on the first four days of the course, and left shortly before the lunch break each day. Lady, and her handler Heather, arrived after the lunch break each day, and attended the afternoon lessons on six days of the course. Buddy, and his handler Amanda, attended the

morning lessons on the last three days of the course. Each dog and their handler were introduced to participants when they first arrived. All dogs were allowed off-lead for the duration of the course, except Adonis who was on-lead for the first two hours on the first morning of the course. There were no restrictions placed on the dogs, and they were allowed to roam freely around the classroom during the lessons. Interaction with the dogs was not structured, in order to allow people to choose the ways and times that were most appropriate and meaningful to interact. In other words, this study aimed to reveal emergent, rather than imposing pre-determined methods of using the dogs.

Classroom observations were recorded through running records and anecdotes for the duration of all lessons by typing directly onto a laptop computer using a Microsoft Access database. A total of 769 observation records totalling 94,336 words were recorded at an average interval of three minutes and 53 seconds.

Veale and Piscitelli (1988) argue that the recorded behaviour of people may not be representative of their normal behaviour since they are conscious of being observed. Thus, the researcher was discretely situated at a small table near the exit door at the rear of the room, in order to reduce the impact of his presence on observed behaviour. Furthermore the researcher changed location on several occasions in order to gain alternate perspectives of the behaviours being observed. As observer-as-participant, the researcher did not engage in classroom discussion with participants, and avoided interaction with the dogs, teachers and students, apart from conducting research interviews.

Ten critical event interviews were conducted; one with the consenting teacher and nine with students. Three consenting students were unavailable to participate in event interviews. These event interviews lasted up to one hour each and were conducted before and after class, and during lunch breaks to minimise the impact of the research

on participants' learning.

Seven repertory grid discussions, and ten post-course interviews were conducted over a periods of up to two hours each between 14 February, 2007 and 22 February, 2007. One post-course interview was conducted the day prior to the end of the course, so as to allow that participant to leave and travel home as soon as the course finished. Four post-course interviews and three repertory grid technique discussions were conducted at Hamptonville Community Training after the completion of the course on the last day. The remaining five post-course interviews and four repertory grid technique discussions were conducted in the eight days following the completion of the course. Three of these were conducted at participants' homes in the evening and on the weekend. The remaining two were conducted at the participants' workplaces during working hours. The post-course interviews and repertory grid discussions with two participants were combined into one because their available time was limited. One consenting participant who completed the course early was unavailable for interview. Another consenting participant did not attend at the arranged time for either the post-course interview or repertory grid discussion, and also did not attend when they were rescheduled. Three of the ten people who participated in the post-course interview discussions withdrew from the repertory grid technique as they felt unable to consolidate their classroom experiences. Event and post-course interviews totalling 20 hours were recorded on audio tape and later transcribed using Microsoft Word.

Trustworthiness

Lincoln and Guba (1985) and Miles and Huberman (1994) argue that the value and significance of qualitative research, and the conclusions that are drawn from it, are often judged against a conventional criteria for trustworthiness that encompasses four aspects: internal validity, external validity, reliability and objectivity. Internal validity

seeks to confirm the truth of the findings by asking the question of how well the research measures what it sets out to measure. External validity seeks to confirm the applicability of the findings to other contexts. Reliability seeks to confirm the extent to which the research findings can be repeated if the research were to be replicated in the same way. Objectivity seeks to confirm the extent to which the findings are not influenced by the biases, motivations, interests or perspectives of the researcher. Lincoln and Guba (1985) and Miles and Huberman (1994) suggest that these four aspects of trustworthiness may be operationalised in a qualitative research paradigm as credibility, transferability, dependability, and confirmability.

Credibility

Lincoln and Guba (1985) and Miles and Huberman (1994) argue that credibility seeks to confirm the truth of the research findings by asking the question: Do the findings of the study make sense and are they credible? This was achieved in this research through considering the size of the sample, prolonged engagement, persistent observation, triangulation, peer debriefing and negative case analysis.

Sample Size

The question arises whether the number of participants in this study is sufficient to support the credibility of the results. Cottrell and McKenzie (2010) argue that in quantitative enquiry sample size is based on statistical probability and the number of participants generally exceeds 50. In contrast, they suggest that qualitative studies have fewer participants, and the method for determining the size of the sample is less structured and based more on the researcher's approach. Additionally, Miles and Huberman (1994) argue that in qualitative enquiry, events, incidents and experiences, rather than the number of people, should also be considered in determining an appropriate sample size. Similarly, Sandelowski (1995), suggest that the number of

interviews and observations conducted, and number of events sampled should also be considered. This is consistent with Lee, Woo and Mackenzie (2002) who suggest that studies such as this one that use more than one method and that use multiple and in-depth interviews with the same participants, require smaller sample sizes.

Mason (2010) argues that the size of the sample should be large enough to uncover all important perceptions without becoming repetitive or superfluous. Mason (2010), Lincoln and Guba (1985), Cottrell and McKenzie (2010) and Guest, Bunce and Johnson, (2006) therefore suggest that researchers should use saturation as a guiding principle when determining the appropriate sample size. For example, Guest, Bunce and Johnson (2006) suggest that the sample is large enough when the researcher keeps hearing the same patterns and no new information is forthcoming. This is consistent with Charmaz (2006) who suggests that the research design is driven by its aims and that a study with modest claims can achieve saturation quickly.

Bertaux (1981) suggests that 15 is the smallest possible number for any qualitative research. This is consistent with Mason (2010) who, in a study of sample size and saturation in PhD studies using qualitative interviews, reported that 33% of 560 studies used sample sizes of 20 or under. Similarly, Guest, Bunce and Johnson (2006) suggest that a sample of 12 is sufficient to describe a shared perception, belief or behaviour amongst a homogenous group similar to that which this study seeks to understand. In the same way, Morse (1994) suggests that phenomenological studies such as this one that are aimed at understanding people's lived experiences can include as few as six participants. This is consistent with Creswell (1998) and Morse (1994) who suggest that phenomenological studies should have at least five participants. Given this discussion, the sample size of this study was considered sufficient to establish credibility.

Prolonged Engagement

Lincoln and Guba (1985) describe prolonged engagement as the investment of sufficient time to learn the culture of what is being researched. This allows the researcher to test for misinformation introduced by distortions of the researcher or participants, and to build trust. Prolonged engagement in this research was achieved by immersion in the culture and context of vocational education and training in Australia, immersion in the culture of the course, and immersion in the culture of dogs in society. Immersion in the culture and context of vocational education and training in Australia was gained through the researcher's 26-year professional practice in the field as a designer of instructional material and teacher of adult training courses. Immersion in the culture, constituted by the classroom environment that was the subject of this research, was gained by attending the full course. Immersion in the culture of dogs in society was achieved through a review of the literature over a period of eight years, and through the purchase of a dog during the period of data analysis and thesis writing. The researcher's daily interactions with the dog, as well as other people's interactions and perceptions of it, were recorded in the researcher's journal. The process of critical reflection on these personal experiences over an extended period of time broadened and deepened the understandings of the research, and contributed to building the credibility of the research.

Persistent Observation

Lincoln and Guba (1985) suggest that persistent observation provides depth to the research by focussing in detail on elements that are of most relevance to answering the research questions. Davis (1992) argues that persistent observation involves using adequate numbers of sources and perspectives of data collection to allow for adequate study of the cultural context, and adequate checks for misinformation. In this research

persistent observation was achieved by using a number of techniques to gather data from different perspectives. Persistent observation was also achieved by collecting extensive data, which was constituted by over 94,000 words of classroom observations and 20 hours of interviews. Additionally, data collected over the complete duration of the course resulted in saturation where there were no more data left to collect. Persistent observation was also achieved by using techniques suggested by Lincoln and Guba (1985) that included sorting relevancies from irrelevancies, and by recursively exploring salient factors until they were seen as either erroneous or meaningful in answering the research questions.

Triangulation

Deising (1972) suggests that triangulation improves the credibility of findings through contextual validation by comparing data collected with other kinds of evidence on the same point from different sources. The research design described earlier in this chapter outlined how triangulation was achieved by collecting data from three different perspectives, that is, observation of students' and teachers' behaviours, students' perspectives of their own and other's behaviour, and a teacher's perspectives of her own and her students' behaviour. Triangulation was also achieved by using six different data collection techniques, that is, a pre-course questionnaire, event interviews, a repertory grid technique, classroom observations, post-course interviews, and the researcher's personal journal.

Peer Debriefing

Lincoln and Guba (1985) explain that peer debriefing is a process of exposing thoughts and ideas to disinterested colleagues to explore what might otherwise remain implicit within the researcher. Peer debriefing occurred through structured sessions that were held throughout the research with the researcher's professional colleagues, and by

participating in both formal and informal post-graduate meetings with academic peers. Additionally, the researcher met informally with professional colleagues from different businesses within the vocational education and training sector throughout the study to discuss emerging thoughts and ideas. In 2008, during the period of analysis, the researcher participated in a small group of post-graduate peers from different universities who meet informally once a month to explore thoughts and ideas regarding individual research projects. Occasionally during the study, the researcher also engaged in post-graduate forums where emerging ideas and thinking were exposed to peers at James Cook University.

Negative Case Analysis

Lincoln and Guba (1985) argue that negative case analysis is to qualitative data what statistical tests are for quantitative data. They describe it as a process of refining a hypothesis based on emergent data until it accounts for all known cases without exception. In this research, a method of negative case analysis suggested by Robinson (1951) was used. First, a phenomenon was tentatively identified from an individual instance and a hypothesis was then formulated around it. Second, the hypothesis was compared with alternative possibilities taken from other instances and where the hypothesis failed to be confirmed, the phenomenon was redefined or the hypothesis revised to include the new instance. Additional cases were then examined and the new hypothesis was repeatedly confirmed and revised.

Transferability

Lincoln and Guba (1985) and Miles and Huberman (1994) describe transferability as the extent to which the research findings are transferable to other contexts. According to Lincoln and Guba (1985), transferability is the qualitative parallel of external validity or generalisability that in conventional paradigms, is

absolute when conditions for randomisation and sampling are met. They point out that external validity is different to transferability, which is always relative and depends on the degree to which similar conditions overlap. Guba and Lincoln (1989) argue that the “burden of proof for claimed generalizability is on the *inquirer*, while the burden of proof for claimed transferability is on the *receiver*” (p. 241).

Qualitative research therefore does not seek to claim generalisability. Instead, Lincoln and Guba (1985) argue that it aims to provide enough detailed information about hypothesis, time, place, context and culture in which the results were found, so that the reader, can make their own decisions as to how the results may apply to their situations:

If there is to be transferability, the burden of proof lies with the original investigator than with the person seeking to make an application elsewhere. The original inquirer cannot know the sites to which transferability might be sought, but the applicators can and do. The best advice to give to anyone seeking to make a transfer is to accumulate *empirical* evidence about contextual similarity; the responsibility of the original investigator ends in providing sufficient descriptive data to make such similarity judgments possible. (p. 298).

Transferability was addressed in this research through the use of thick descriptions, as suggested by Lincoln and Guba (1985), to provide the reader with an understanding of: the macro-, mezzo- and micro-environments within which the research was conducted; the people participating in the research; the time and context within which the research results were found to hold; and rich narrative through the use of the repertory grid technique and semi-structured interviews.

Dependability

Lincoln and Guba (1985) and Miles and Huberman (1994) describe dependability as the extent to which the research methodology is consistent and stable over time and across researchers and methods. Dependability was achieved in this research by using methods of triangulation that overlapped with those used to establish credibility. Lincoln and Guba (1985) suggest that there can be no credibility without dependability, and therefore having earlier demonstrated credibility in this research should sufficiently establish its dependability.

Confirmability

According to Lincoln and Guba (1985) and Miles and Huberman (1994), confirmability seeks to establish the neutrality of the research, that is, the freedom from or articulation of bias. This was achieved in this research through establishing an audit trail and by providing a thick description of the role of the researcher.

Audit Trail

Miles and Huberman (1994) describe the audit trail as a method of logging and describing the research process in sufficient detail to allow others to understand it, reconstruct it and subject it to scrutiny. Along with Lincoln and Guba (1985), they argue that such scrutiny cannot occur without a residue of records from the research. These records include raw data, the products of data reduction and analysis, the products of data reconstruction and synthesis, process notes, materials relating to intentions and dispositions and information regarding the development of research instruments.

Presented at Table 3 is the audit trail for this research, which was established through records that included field notes, memos, electronic communications, records of discussions, personal notes, the researcher's journal, letters, classroom observations,

Table 3

Research Audit Trail

Audit trail classification	File type	Evidence
Raw data	Electronically recorded materials	Running records Anecdotal records
	Field notes	Audio tapes
	Unobtrusive measures	Interview transcripts
	Survey results	Literature review Public documents Completed surveys Researcher's journal Description of events, characteristics of environment and character studies of participants
Data reduction and analysis	Write up of field notes	Summarised transcripts
	Summaries	Summarised observational records
	Theoretical notes	Temporal maps Computer analysis Statistical analysis Researcher's journal Emergent codes Code summaries

Audit trail classification	File type	Evidence
		Description of emerging themes Draft thesis Electronic communications Memos
Data reconstruction and synthesis	Categorical structure Findings and conclusions Final report	Hierarchies of concepts and categories Explanation of concepts Draft thesis Electronic communications Researcher's journal Memos
Process notes	Methodological notes Trustworthiness notes Audit trail notes	Draft methodology Email communications Draft thesis Minutes of meetings Status reports Draft instruments Researcher's journal Notes on peer debriefing meetings Dates of prolonged engagement Calendar and schedule
Intentions and	Proposal	Research proposal

Audit trail classification	File type	Evidence
disposition	Personal notes	Bibliography
	Expectations	Draft thesis
		Research proposal presentation
		Researcher's journal
Instrument development	Pilot and preliminary	Draft interview guides
	schedules of questions	Results of instrument pilots
	Observation formats	Feedback notes
	Surveys	Final instruments

audio tapes, transcriptions, and records of peer debriefing meetings. The researcher's journal was also used to increase the trustworthiness of the research by providing information about methodological decisions, and the reasons for making them as suggested by Lincoln and Guba (1985). The researcher's journal contributed to developing an audit trail as a method of establishing confirmability of the research in ways suggested by Lincoln and Guba (1985) by displaying the researcher's cognitive processes, philosophical position, the bases of decisions about the research, and revealing the extent to which the researcher's biases influenced the outcomes.

Gold (1958) identified four roles of the qualitative researcher: the complete participant; the participant as observer; observer-as-participant; and complete observer. The complete participant interacts as a fully participating member of those being studied by adopting the role of an insider, and their identity and purpose are unknown to those being studied. The participant as observer interacts as a participating member of

those being studied and their role and purpose are made aware to those being studied. The observer-as-participant interacts only briefly and minimally with participants and their identity and purpose are known to those being studied. The complete observer is removed from any interaction with participants and is unknown and often unseen by those being studied.

In this research, the role of the researcher was observer-as-participant, whose identity and presence was known to those being studied, and whose interaction with them was limited to observations, interviews and administration of the repertory grid technique. It was pointed out earlier that according to Veale and Piscitelli (1988), the recorded behaviour of people may not be representative of their normal behaviour, if they are conscious of being observed. However, they also suggest that the observer who is a regular participant in the environment being observed, such as was the case during this research study, is less likely to be of concern to those being observed. Conversely, Atkinson and Hammersely (1994) suggest that merely being present in the environment may have constituted participation and could have influenced people's behaviour and social interactions. This was indicated in the following excerpt from one of the post-course interviews:

I think the fact that you were there with the dogs had an influence, on that they felt that they were being observed. I just felt they were conscious of you being there...and you weren't one of the students. I think it might have made them a little bit more conscious of what they did...I think they assumed that...they could sort of pull the wool over everyone's eyes and you know, we wouldn't ask any questions. And yet when you were there, you might have had that knowledge.

The researcher's career spans 26 years as a designer of instructional material and as a teacher within vocational education and training settings in private, public and not-for-profit organisations. The researcher has taught several hundred classes ranging from technical operator training to leadership and management subjects. The researcher's academic qualifications include a Diploma of Business, Diploma of Management, Bachelor of Business and Masters of Education. He holds a special interest in the process of adult learning and is an accredited trainer and assessor under the Australian Quality Training Framework. The researcher is also an accredited practitioner of two personality assessment inventories, the Myers-Briggs Type Indicator for psychological type and the 16 Personality Factor instrument. The researcher has not at any time been employed or otherwise engaged by or associated with any veterinarian organisation, medical or pet food company, animal assisted therapy association except Delta Australia, or any political or social organisation that may give rise to bias through conflict of interest.

The researcher's experience with dogs as a child was gained by visiting other homes. His experience as an adult with dogs prior to this study was gained through interaction with the pets of friends and family, and he had only resided in domestic situations where dogs were present for less than one year. The researcher had not personally raised or owned a dog prior to this study. He has a positive disposition and orientation towards dogs as companion, assistance and therapy animals, as well as a strong personal value commitment to the positive role that dogs play in society and the contribution they make to improve the quality of life. These personal beliefs have also been influenced by an experience where the researcher's partner was visited in hospital by a therapy assistance dog to assist in recovery after surgery to remove cancer.

The researcher's knowledge of and experience in conducting qualitative research, and the use of the qualitative interview, has been gained through academic study. It has also been gained by analysing training needs and evaluating learning outcomes as a constant practice in his professional career. However, this study is the researcher's first experience in conducting qualitative research of such depth and rigour, his first experience in classroom observation and his first use of the repertory grid technique. The researcher balanced this lack of experience by reviewing the literature, piloting classroom observations over a period of ten, four-hour teaching sessions, and piloting the repertory grid technique with five colleagues and one research participant.

Analysis

This research generated two sets of data: qualitative data collected through interview and classroom observations; and data collected through the repertory grid technique. This section provides a description of the approaches used to analyse these sets of data and the techniques and methods used to transform them into findings.

Interview and Observational Analysis

Approach to Data Analysis

It was pointed out earlier that the framework for this research was rooted in grounded theory that, as Haig (1995) and Trochim and Donnelly (2007) argue, seeks to develop a theory to explain the phenomena by using an iterative analytical process. Grounded theory is an inductive way of thinking about and conceptualising the data. Therefore two inductive strategies suggested by Goetz and LeCompte (1981) and Lacy and Luff (2001), that were compatible with the overall ethnographic design approach to the research, were used to analyse the data. These strategies were constant comparison and analytic induction. Constant comparison was used in ways suggested by Lacy and Luff (2001) and Thorne (2000), to compare concepts and categories emerging from one

piece of data such as an interview, statement or theme, with others to explore the possible relationships between them. A technique of analytic induction suggested by Robinson (1951) was used to formulate hypotheses around instances of phenomena, and through an iterative process of comparison with other occurrences, this was continually refined to account for all of them. This technique was also used as a method of negative case analysis that contributed to establishing the credibility and trustworthiness of the research.

Data Reduction

The analysis of the research data commenced with data reduction, as suggested by Miles and Huberman (1994). Along with Krathwohl (2004), they argue that data reduction is concerned with making the corpus of data more meaningful and easy to interpret by paring away that which is of less importance, in order to reveal what is significant. The process of reduction of the interview data started with the transcribing of the audio tapes that, as suggested by Krathwohl (2004), also enabled the researcher to pick up on subtle cues such as inflections indicating surprise, irritation or apathy. The method suggested by Bazeley and Richards (2006) was then used to reduce the data into a manageable form. This method involved firstly re-reading the transcript data in small sections and answering three questions: what is interesting here, which helped identify phenomena of interest; why is that interesting, which helped generate useful descriptive and interpretive codes or labels for the phenomena; and why am I interested in that, which generated more abstract concepts. These abstract concepts were of general use in the coding system when concepts and categories were organised into a more structured system, as suggested by Bazeley and Richard (2006).

Presented in Table 4 is an extract from the analysis of Coral's critical event interview, which is included in full at Appendix G. It provides an example of how this method was applied to generate three codes: *non-distraction*, *content focus* and *situation awareness*:

Eriksson, Lindahl and Bergbom (2010) describe a hermeneutic method of analysing observational data that is consistent with the phenomenological and ethnographic framework on which this research is founded. This method was used to view the text as a dimension of art that created a scene, and that could be observed in the same way as a theatre play, containing a cast of lead and supporting actors, props, setting, plots, sub-plots and script.

The first step was to organise the text into a script similar to a theatre play, and to summarise the main plot of the lesson, that is the description of what was taught, how it was taught, and the learning interactions of students. This was then followed by identifying and summarising the sub-plots of each of the main actors an example of which is presented at Appendix H. These plots described: the behaviour of the dogs; people's social interaction; student and teacher behaviours such as micro-conversations, leaving the room, yawning, looking out the window, watching the dog, playing with the dog, standing up for extended periods; and the behaviour of visitors and the use of mobile phones and other artifacts. This method rendered the corpus of data easy to interpret because, as suggested by Krathwohl (2004) and Miles and Huberman (1994), it removed details that were distracting and unimportant. It also revealed patterns and themes of significance, such as the richness of people's interactions with the dogs, rule-making and breaking, and the development of socialisation. The next step in reducing the interview and observational data also formed the first step in constant comparison. Indicators of categories were identified and were named using open coding. During

Table 4

Extract from Analysis of Coral's Critical Event Interview

Transcript and reflection	Code
<p>RESEARCHER: I just wanted to catch up with you about a couple of things, and just get your thoughts on a couple of things.</p>	
<p>CORAL: Yes, okay.</p>	
<p>RESEARCHER: that have happened. One in particular that I was interested in finding out a little bit about was Adonis and the barking incident, when the dogs walked past.</p>	
<p>CORAL: When was that? Oh.</p>	
<p>RESEARCHER: In the morning.</p>	
<p>CORAL: Yes.</p>	
<p>RESEARCHER: What was your thoughts, what, on what happened then?</p>	
<p>CORAL: I don't think I was thinking about what happened then.</p>	
<p>RESEARCHER: Okay, 'cause it was quite a loud bark, and sort of a lot of activity there.</p>	
<p>CORAL: Well, I'm used to dogs barking. Truly you've really got to stay pretty focused.</p>	
<p>RESEARCHER: Uh-huh.</p>	
<p>CORAL: On the delivery. So the dogs haven't</p>	

Transcript and reflection	Code
<p>really impacted that much I don't think. You've just got to stay focused on what you're doing.</p>	
<p>What is interesting here is that she was focused on the course to such an extent that she was unaware of the actions of the dog, and her expressed need to, "stay focused on what you're doing." What is also interesting is that she does not mention the impact that it may have had for other people, only herself. What is also interesting is that the story started with a discussion about the dog barking incident, yet ends with her need to stay focused on the course.</p>	<p>Content focused Non-distraction Situation awareness</p>
<p>That is interesting because it emphasises how her focus was turned inward to her own concerns to such an extent that if she was unaware of the dogs behaviour, she was possibly unaware of the behaviour and concerns of other people as well. The need to stay focused may imply the difficulty she may have been experiencing with the content and the delivery. It is also interesting because she does not display concern or empathy for others either in regard to the impact of the dog, or the difficulty that others may or may not have been having with the course.</p>	
<p>I am interested in that because Coral appears to place</p>	

Transcript and reflection	Code
<p>greater importance on focusing on the content of the course, which she implies is difficult, rather than her surroundings and may be evidence of the desocialising impact that the delivery of, and the content itself may have had on Coral and possibly other people. It may also indicate an egocentric view of the learning experience.</p>	

open coding, labels describing the phenomena were derived inductively from the data itself, as suggested by Strauss (1987) and Kalnins et al. (Kalnins et al., 2002).

Krathwohl (2004) and Miles and Humberman (1994) have suggested that the use of computer software can greatly assist in the process of coding and comparing the data. Several attempts were made by the researcher to use both Nvivo and Atlas.ti to assist with this. However, these software programmes proved cumbersome, and difficult to learn and use. The software became an artifact that stood between the data and the researcher and made it more difficult to understand. Accordingly, codes were recorded using the less sophisticated method of making electronic and handwritten marginal notes. Examples of this coding technique for the interview and observational data are presented at Appendix G and Appendix H.

These codes were compared to find similarities and differences in the manner suggested by Morse and Field (1995) and Strauss (1994), that revealed categories and themes to described the phenomena. Methods suggested by Lofland and Lofland (1984), Patton (1990), Pelligrini (1991) and Spradley (1980), were used to organise these codes. These methods included: ethograms that catalogued behaviours grouped in

categories; typologies that organised codes into parsimonious classifications derived from patterns, themes and other groupings; and taxonomies that organised codes into hierarchical domains. Techniques suggested by Ryan and Bernard (2003) were also used to identify themes within the data. These techniques included: repetitions of recurring topics or regularities; the use of metaphors, similes and analogies; transitions in dialogue where the naturally occurring shifts in content may mark themes; linguistic connectors such as *because*, *if*, *is a*, and *before*; lacuna that looks and what is inferred or not mentioned; and enumerative techniques such as word counts, word lists and word co-occurrences. Examples of categories including exemplars and outliers were also identified to define the limits of the category, as suggested by Ratcliffe (2009). Finally linkages between categories were identified including linkages of time, space, causation, social and the interpersonal. Reported in Table 5 are the 55 codes across 13 categories that this method produced from the original 460 codes used to describe the interview data. Reported in Table 6, are the 75 codes across seven categories that this method produced from the original 1,146 codes used to describe the observational data.

Data Display

The second major flow of the analysis was to assemble an organised compression of the information by creating data displays, as suggested by Miles and Huberman (1994). These data displays helped describe what was going on in the manner suggested by Miles and Huberman (1994), by showing the component parts of the phenomena and explaining how the component parts fitted together according to a set of rules, which allowed the researcher to draw conclusions.

Data displays are often thought of in terms of a quantitative research paradigm, of which histograms, correlation matrices, scatter plots, factor plots and box-and-whisker displays are examples. However, Miles and Huberman (1994) point out that

Table 5

Results of Interview Code Reduction and Categories

Category	Code
	Domains of interaction
Reaction to dog behaviour	Perception of barking (reflection on interaction)
	Unexpected spontaneous
	Under the tables - amusing
	Coral conflict and Alma
	Acceptable dog behaviour - rule making
Characteristics of interaction	Appealing characteristics
	Social Influences
	Enculturation
	Perceptual blindness
	Physical environment
	Dogs contrasted with computers
	Environmental context
Task environment	Course structure
	Learning styles expectations
	Timewasting
	Teacher competence
Social environment	Human agency
	Socialisation

Category	Code
Emotional environment	Emotion
	Motivation
Physical environment	Environment
	Contrasting use of artifacts
	Computer fear
	Other artifacts
	Like a corral in the library (other artefacts)
Cognitive environment	Blindness
	Distraction
	Like a Friday afternoon (emotional climate)
	Like a Poker game (oppression)
	Like a shield (environment)
	Like a curtain went down (motivation)
	Social influence
Perception	Dogs Influence on perception of others
	Perception of others
Socialisation	Dog influence on socialisation
Concern	Concern for dog
	Concern for others
	Practical concerns
	Responsibility (whose concern, not mine)
Acceptance	Acceptable social behaviour - rule making

Category	Code
Emotion	Acceptance tolerance
	Valuing Differences
	Like a whirlpool (perception of others)
	Like a budget (acceptable behaviour)
	Emotional influence
	Dog influence on emotion
	Emotional climate
	Like having the windows open (emotional climate)
	Like being on holidays (emotional climate)
	Cognitive influence
Cognition	Concentration
	Breaks
	Dog Lessons
	Distraction
	Like a cigarette
	Like an aide
	Like a desk toy
	Negative case
	Dog no influence
	Orientation to dogs

Table 6

Results of Observational Code Reduction and Categories

Interaction	Socialisation	Teacher	Dog behaviour
Hug	Goodbye	Teacher voice	Approach
Pat	Hello	Teacher language	Wander
Watch	Introduction	Teacher body	Under
Andy Mintie	Welcome	Break	Lick
Play	Thank you	Announce break	Tangle
Reach	Ground Rules	Unannounced break	Lay
Coax	Reggie absent	Privilege	Stand at door
Crackle	Applaud	Praxis	Bark
Ask to feed			Whimper
Ignore dog	Student behaviour	Other artifacts	Jump
No watch			Wag
Step over	Dancing	Computer	Roll
Student talk to	Singing	Solitaire	Chew
Teacher talk to	Stretch	Web site	
Student talk about	Sigh	Whiteboard	
Teacher talk about	Yawn	Food	Student Voice
Incorporate dog	Look away	Phone	
	Look out	Projector	Student voice
	Students pack up	Book	Video
	Student behaviour	CD	Temperature

Interaction	Socialisation	Teacher	Dog behaviour
	Student Body	Newspaper	Humour
			Student language

within a qualitative research paradigm there are two types data displays: matrices that are the crossing of two lists of data represented as rows and columns; and network displays that are a collection of points known of as nodes that are connected by lines representing links between them.

Variable-oriented and process-oriented data displays were built using Microsoft Excel, Microsoft Word and Microsoft Visio from coded and transformed data segments. The variety of data displays used to describe phenomena revealed by the data included: partially ordered displays; time ordered displays, a sample of which is included at Appendix I; role ordered displays; and conceptually ordered displays. Explanatory effects matrices, case dynamics matrices and causal networks were used to explain the plausible reasons why the phenomenon was occurring and to reveal possible causalities.

Conclusion Drawing and Verification

The data displays showed reduced, focused and organisation information in one location, as suggested by Miles and Huberman (1994). Therefore the researcher was able to absorb large amounts of information quickly and could undertake careful comparisons, detection of differences, noting of patterns and themes, and identification of trends. This led to the last major flow of analysis: conclusion drawing and verification. Conclusions were drawn using techniques described by Miles and Huberman (1994), which included noting patterns and themes, and building a logical chain of evidence from which hypotheses emerged inductively that attempted to link

factors together and to explain the relationships between them. A technique of analytic induction suggested by Robinson (1951) was then used to verify and further refine the emergent hypotheses. This technique was described earlier, since was used to formulate hypotheses around instances of phenomena, and through an iterative process of comparison with other occurrences, it was continually refined to account for all of them. Zero exception was not a desired goal because, as noted by Lincoln and Guba (1985) it is too rigid and its achievement may be difficult to believe. This is because there are situations where one may expect to find exceptions when the hypotheses are valid, such as expected lies, fronts and other deliberate or conscious deceptions, which cannot always be fully penetrated.

Repertory Grid Technique Analysis

Repertory grids were analysed using Idiogrid (Grice, 2007) and GridSuite (Bacher & Fromm, 2004) software to produce bivariate statistics, and conduct principal component and cluster analyses. Bivariate statistics were used to examine the relationships between constructs and elements. Principal component analysis was used to compress constructs to a smaller number that accounted for the spread of data. Cluster analysis was used to examine natural groupings amongst constructs and elements, and the similarities and differences they shared. The software programme Idiogrid (Grice, 2007) provided a comprehensive suite of statistical methods that was affordable, ran under the Windows operating environment, and produced output that could be exported into formats for reporting. Cluster analysis and the creation of dendograms were not available in Idiogrid (Grice, 2007) and were created using the software programme GridSuite (Bacher & Fromm, 2004).

Easterby-Smith, Thorpe and Holman (1996) argue that the statistical methods used for analysing grid data are mostly concerned with exploring the variations amongst

and within the data, rather than the similarities, and can be effective in exploring latent meanings. However, along with Fransella and Bannister (1977), they caution there is a potential that the methods used may increase a distance between the researcher and that being researched. Thus, to avoid compromising the repertory grid data, Gammack and Stephen (1994) suggest that any statistical analysis must be viewed alongside a qualitative appreciation of the data. This was achieved by writing thick description of the constructs elicited from interviewees' perspectives and referencing the grids to transcripts of the interviews. This allowed the researcher to move between the data, interviewees and the researcher's interpretation of that data, as suggested by Easterby-Smith, Thorpe and Holman (1996). Presented at Appendix J is a detailed description of the methods used to analyse the repertory grid data, which the reader is encouraged to examine.

Summary

This chapter presented a framework for the research methodology employed in this study. This framework adopted a phenomenological perspective that focused on exploring participants' subjective experiences and their interpretations of the world to reveal how they viewed and understood the world around them. This framework also used an ethnographic approach that emphasised the culture formed by the students, teachers and dogs in a naturalistic environment.

This research focused on the lived experiences and reflections of two teachers and 15 adult students who interacted with three dogs during the six and a half day *TAA40104 Certificate IV in Training and Assessment* course conducted by Hamptonville Community Training, a training organisation in northern Australia. Dogs and their volunteer handlers were recruited from Delta Society Australia's *Pet Partners Therapy Dogs Programme*. The ethical requirements for conducting this research

included privacy, confidentiality, security, health and safety. These requirements were met through a formal review process with James Cook University's Animal Research Ethics Review Committee and Human Research Ethics Review Committee. Formal approval was received from both committees (approval numbers A1149 and H2455). The research was then conducted according to those requirements. Trustworthiness was established by addressing credibility, transferability, dependability and confirmability using techniques suggested by Lincoln & Guba (1985) and Miles and Huberman (1994). These included considering the size of the sample, prolonged engagement, persistent observation, triangulation, peer debriefing, negative case analysis, providing thick descriptions, and maintaining an audit trail.

The researcher as observer-as-participant used six techniques to gather data: a pre-course questionnaire, classroom observations, a critical events technique, a repertory grid technique, post-course interviews, and the researcher's personal journal. A pre-course questionnaire was used to capture demographic data about the research participants and to help build a picture of people's backgrounds and profiles. Classroom observations were recorded using running records for the duration of the course, and semi-structured interviews were used to capture perceptions and reflections on their experiences following critical events. George Kelly's (1955) repertory grid technique enabled people to verbalise how they perceived elements or facets within the classroom domain that helped construct a picture of their concept models. It also served as a tool for the collection of the students' and their teacher's narratives at the completion of the course by stimulating dialogue. Finally, the researcher's journal revealed information about self and method at regular and spontaneous moments during the life of the research.

Analysis of the interview and observational data drew on grounded theory that sought to develop hypotheses to explain phenomena using an iterative analytical process. This process employed two inductive strategies: constant comparison and analytic induction. The repertory grid data was analysed using Idiogrid (Grice, 2007) and GridSuite (Bacher & Fromm, 2004) software to produce bivariate statistics, and conduct principal component and cluster analyses. Bivariate statistics were used to examine the relationships between constructs and elements. Principal component analysis was used to compress constructs to a smaller number that accounted for the spread of data. Cluster analysis was used to examine natural groupings amongst constructs and elements, and the similarities and differences that they shared.

The following chapter presents the results of the data collection as well as the analysis and will build the logical chain of evidence used to develop emergent hypotheses and findings presented in chapter 5.

CHAPTER 4: RESULTS

Introduction

Chapter 1 introduced the aims of this research and highlighted two questions that it seeks to answer: In what ways do people use dogs as mediating artifacts in their meaning-making processes; and what are the effects of dogs in mediating individual and group learning processes?

Chapter 2 examined the body of literature surrounding the context within which the research is located, and explored the vocational education and training sector in Australia as an example of contemporary models of teaching and learning. This view of adult learning was contrasted with the social constructivist framework that emerged from the Soviet school of sociocultural theory, central to which is the concept of artifacts that mediate human understanding. Finally several ways that dogs may be seen to function as artifacts in society were examined to provide a framework on which to scaffold thinking in answering the research questions.

Chapter 3 drew from the literature to construct a framework for the research methodology that was employed in this study. It also provided a detailed procedure for conducting the research, a description of the data collection tools and methods used, and a description of the techniques and methods employed to analyse the data.

This chapter will present and explain the results of the data collected and will build the logical chain of evidence used to develop the emergent hypotheses and findings presented in chapter 5.

Participants

There were 20 participants in this research: one core and one auxiliary teacher, three dogs, three students who attended the course for three days, and 12 students who

attended for the full six and a half days. Additionally, there were a several visitors who were present for short periods of time.

Students and Teachers

Reported in Table 7 is a synopsis of the students and teachers who participated in this research. Two students who attended the course, Andy and Reggie, experienced back injuries and were noticeably in pain. Andy had recently injured his back in a motor accident. He visited a doctor each lunch time to receive injections and medication. During the afternoon sessions his speech was slurred and he appeared to be heavily medicated. On two occasions Andy left the class early because of his injury. Tanya told the class at the beginning of the course that Reggie was given a large cushioned, canvas-upholstered chair from an outdoor setting because of her injury. Reggie was present only on the first day, the morning of the second day, the third day, and the morning of the fourth day. Her total time in attendance was three days.

The students and teachers who participated in this research appeared to fall into three groupings. The first group may be described as major actors. These people participated in all but one of the data collection methods, though not all participated in the same ones. Consequently, a large volume of rich data was collected from the major actors, and therefore a great deal is known about them, including their social and vocational histories, orientation towards and experiences with dogs and animals and their perceptions and beliefs. Additionally, major actors attended at least five out of the six and a half days of the course and because they spent more time in the environment with the dogs than minor actors and visitors, more observational data about them was collected than was the case with the characters in other groupings. The major actors were Andy, Brad, Borat, Dan, Danni, Mary, Morgan, Leigh, Sam, Sharon and Wynnie.

Table 7

Synopsis of Participants

Name	Gender	Role	Age	Occupation
Major Actors				
Andy	M	Student	Early 40s	Drilling rigger on a mine site.
Borat	M	Student	32	Recently migrated from the Czech Republic with his family, and who had recently left his job.
Brad	M	Student	54	Machinery operator trainer who has lived and worked all of his life in rural outback Australia.
Dan	M	Student	51	Husband of Sharon and a Health and Safety and Training Officer for a resources company.
Danni	F	Student	48	Recently promoted to the role of Training Facilitator for a mining company.
Leigh	F	Student	29	A qualified solicitor who worked as a Conciliator with the Antidiscrimination Commission.
Mary	F	Student	49	Aboriginal and Torres Strait Islander Engagement Officer for the Department of Education.

Name	Gender	Role	Age	Occupation
Morgan	F	Student	22	Managed a day care centre in Hamptonville and joined the class on the second day.
Sam	F	Core teacher	45	The core teacher.
Sharon	F	Student	49	Wife of Dan, and owner of machinery and plant procurement business located 90 minutes west of Hamptonville.
Wynnie	F	Student	30	Telecommunications technician, who lived in rural outback Australia.
Minor Actors				
Alma	F	Auxiliary teacher	Mid-twenties	Occupational therapist, who was the auxiliary teacher for the course.
Andrea	F	Student	Late-twenties	Massage therapist.
Coral	F	Student	52	Teacher of English as a Second Language who attended the first three days only.
Mark	M	Student	63	Mining machinery plant operator who worked in rural Australia.
Reggie	F	Student	Middle-aged	Community youth welfare worker who attended three days only.

Name	Gender	Role	Age	Occupation
Wade	M	Student	38	Supervisor for an army workshop who was re-skilling for civilian life and who attended the first three days only.
Visitors				
Johannes	M	Technician		Computer technician.
Narelle	F	Administrator		Administration assistant.
Sarah	F	Administrator		Course administrator.
Tanya	F	Owner		Owner of Hamptonville Community Training.
Alicia	F	Handler	Mid-twenties	Adonis' handler
Amanda	F	Handler	Middle-aged	Buddy's handler
Heather	F	Handler	Middle-aged	Lady's handler

The second grouping of people can be described as minor actors. These people participated in only one or two data collection methods. Many minor actors declined to participate in, or did not make themselves available for interviews or for the repertory grid technique. Consequently, less data was collected from minor actors and less is known about them compared to the major actors. Additionally, many minor actors attended three or less days of the six and a half day course, and thus spent less time in

the environment with the dogs than major actors. Therefore, less observational data about them was collected than was the case for the major actors. The minor actors were Alma, the auxiliary teacher, Andrea, Coral, Mark, Wade and Reggie.

The third grouping of people can be described as visitors, who were not the target population of the research but entered the environment for short periods of time, and about whom only minor observational data was collected. Visitors included Tanya, the owner of Hamptonville Community Training, several administrative support staff, two stray dogs, an information technology officer, and a course coordinator. The dog handlers, Alicia, Amanda and Heather, were also included as visitors because of their support role and minor influence on the research. On one occasion Johannes fulfilled the role of teacher when he led the class for the second teaching period of day four. Tanya also fulfilled the role of teacher on four separate occasions, though not for full teaching periods.

The Dogs

The three dogs Adonis, Buddy and Lady, were also included as major actors because of their essential role in the research.

Adonis

Adonis was a medium-sized, short haired, blond, four-year old Labrador and was accompanied by his handler, Alicia. Adonis was a very social dog, frequently initiating interaction with people as he wandered around the room and under the tables. Adonis was initially on the lead during the first teaching period, after which he was allowed to roam freely. A jumble of power cords and network cables under the tables connected the computers and as Adonis wandered underneath and in the centre of the tables he would occasionally get caught in them. Agreement was reached with Tanya after the first day that a wooden container be placed in the centre of the tables to cover

the exposed cabling. Adonis and Alicia were present in the morning sessions for the first four days of the course.

Buddy

Buddy was a small, white, long-haired, three-year old Cavoodle, a cross breed between a King Charles Spaniel and Poodle that was accompanied by her handler, Amanda. One of Buddy's most appealing features was his large dark eyes. Buddy was very sociable, often initiating interaction with others and wandered freely. Buddy was allowed off-lead for the entire time, and along with Alma, was present in the classroom in the morning sessions for the last three days of the course.

Lady

Lady was a large, long-haired, black and tan, four-year old German Shepherd and was accompanied by her handler, Heather. Lady was an Australian championship winner and a well-disciplined and well-trained dog who readily obeyed commands. She would not venture away from Heather unless instructed. This meant that when Heather was reading a book, Lady would lie down next to her unmoving for long periods. Lady would occasionally initiate interaction with people when encouraged by Heather to wander. Lady was allowed off-lead for the entire time, and along with Heather, was present in the classroom for the six afternoon sessions of the course.

Attendance

Reported at Table 8 is a summary of the attendance of students, teachers, dogs and their handlers. The course was broken into four teaching periods each day. The first period was between the start of the day and morning tea. The second period was between morning tea and lunch. The third period was between lunch and afternoon tea, and the fourth period was between afternoon tea and the end of the day's lessons.

Name	Teaching period																									
	Day 1				Day 2				Day 3				Day 4				Day 5				Day 6				Day 7	
	1	2	3	4	1	2	3	4	1	2	3	4	1	2	3	4	1	2	3	4	1	2	3	4	1	2
Tanya	•							•												•						•
Wade	•	•	•	•	•	•	•	•	•	•	•	•														
Wynn	•	•	•	•	•	•	•	•	•	•	•	•	•	•	•	•	•	•	•	•	•	•	•	•	•	•

Research Participation

Reported at Table 9 is a summary of the participation of students and teachers in the research. A total of 14 participants completed the pre-course questionnaire, ten took part in event interviews, 11 in post-course interviews, and eight in the repertory grid technique. Three students, Andrea, Reggie and Wade, and one teacher, Alma, declined to participate in both the event interview and post-course repertory grid technique discussions. An additional two students, Coral and Mark who participated in event dialogue discussions, were unable to attend the post-course repertory grid technique discussions. Two students, Andrea and Morgan, and one teacher, Alma, declined to participate in the pre-course questionnaire. Three students who agreed to participate in the repertory grid technique, Andy, Brad and Morgan, experienced difficulty in construing and contrasting differences with other students and the dogs, and therefore the technique was abandoned for these people.

Table 9

Participation Summary

Name	Classroom observation	Pre-course questionnaire	Event interview	Post-course interview	Repertory grid technique
Alma	●	Declined	Declined	Declined	Declined
Andrea	●	Declined	Declined	Declined	Declined
Andy	●	●	Unavailable	●	Abandoned
Brad	●	●	●	●	Abandoned
Borat	●	●	●	●	●
Coral	●	●	●	Left early	Left early
Dan	●	●	Unavailable	●	●
Danni	●	●	●	●	●
Leigh	●	●	●	●	●
Mark	●	●	●	No Show	No Show
Mary	●	●	●	●	●
Morgan	●	No Response	●	●	Abandoned
Reggie	●	●	Declined	Declined	Declined
Sam	●	●	●	●	●
Sharon	●	●	Unavailable	●	●
Wade	●	●	Declined	Declined	Declined
Wynnie	●	●	●	●	●
Total	17	14	10	11	8

Questionnaire Data

Reported at Figure 2 is a summary of participants' orientations towards dogs as stated in the pre-course questionnaire. Of the fourteen people who agreed to participate in the pre-course questionnaire, five people, Andy, Borat, Coral, Sam and Wade, rated their orientation towards dogs as 5 (*dogs are an essential part of life*). Only one student, Brad, rated his orientation towards dogs as 2 (*don't like dogs, but will tolerate them*). The remaining eight participants rated their orientation towards dogs as 4 (*likes dogs*). One student, Morgan, who did not complete the pre-course questionnaire, described her orientation during the dialogue discussion as 2 (*don't like dogs, but will tolerate them*). Through observations of Andrea's behaviour, it is hypothesised that her orientation could be described as 4 (*likes dogs*). Observations of Alma's behaviour and dialogue discussions with students, suggested a hypothesised orientation that could be described as rating 2 (*don't like dogs, but will tolerate them*). These results suggest that most participants had a positive orientation towards dogs. However, Brad's negative orientation provides an alternate case through which to explore the data, themes and hypotheses that emerged from interviews and observations of people with a positive orientation towards dogs.

Reported at Table 10 is a summary of participants' educational achievements as reported through the pre-course questionnaire. Only three people who completed the pre-course questionnaire, Andy, Brad and Mary, stated that the highest level of schooling they achieved was high school. Six people, Borat, Mark, Dan, Danni, Wynnie, and Sam, stated that the highest level they achieved was through post-secondary Technical and Further Education. However, discussions with Borat revealed that he was completing an undergraduate degree course. Five people, Coral,

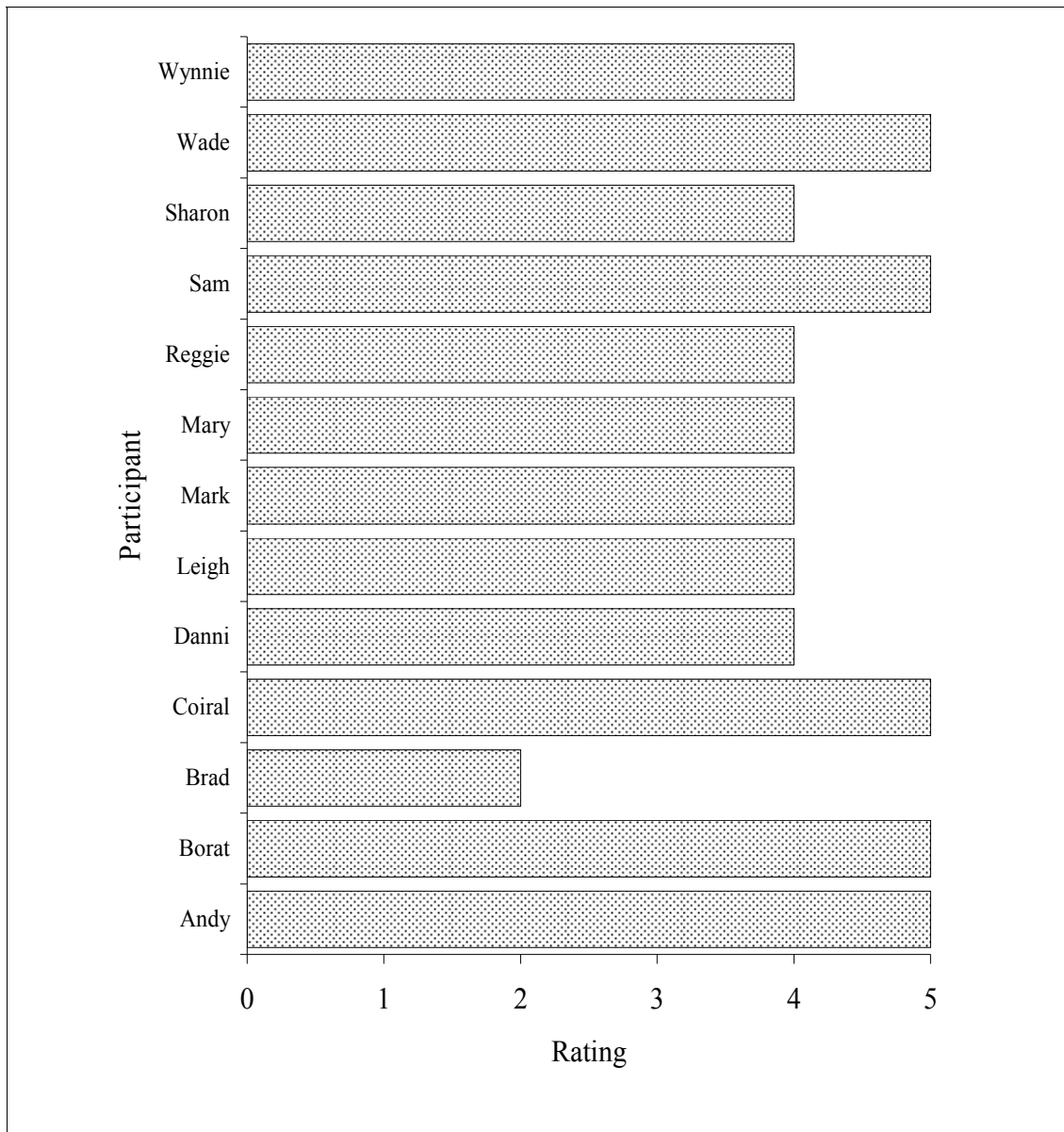

Figure 2. Participants' orientation towards dogs.

Leigh, Reggie, Sharon, and Wade, stated that they had achieved an undergraduate degree or post graduate qualifications, and three students, Brad, Mark and Dan, stated that in the past 30-44 years they had not engaged in education that had led to a formal qualification. These results suggest that there was a diversity of educational achievements amongst the group, and that for many, their educational experiences were gained recently.

Table 10

Participants' Education Achievements

Name	Highest schooling achieved	Last year attended
Andy	High school	1980
Brad	High school	1968
Borat	TAFE	2006
Coral	Post graduate	2002
Dan	TAFE	1973
Danni	TAFE	1999
Leigh	Degree	2001
Mark	TAFE	1963
Mary	High school	Not Stated
Reggie	Degree	2005
Sam	TAFE	2006
Sharon	Degree	2005
Wade	Degree	Yr 11
Wynn timer	TAFE	Not Stated

Reported at Table 11 is a summary of participants' childhood and adult experiences with animals and pets, as reported through the pre-course questionnaire. Only one person, Brad, reported that he did not have any pets as either a child or adult, and did not report any positive or negative experiences with animals. All participants except Reggie and Wade reported that they had dogs as children, and only three participants, Leigh, Mary and Reggie reported that they did not have dogs as

Table 11

Participants' Experiences with Pets

Name	Childhood pets	Adult pets	Positive experiences	Negative experiences
Andy	Dogs, cats, snakes.	Horses and dogs	Good companions.	Bitten by tiger snake and king brown on shoulder.
Borat	Dog, cat, fish, turtle, frog, guinea pig, rat, rabbit.	Dog and cat	It is great to have animals around. I cannot think of anything particular.	None.
Coral	Cats, dogs, birds, guinea pigs.	Dogs (and enjoy wildlife in my garden).	The usual, companionship, fun, etc. Interested in observing behaviour.	Cats killing wildlife, aggressive dog on street, uncontrolled barking of neighbours dogs.
Dan	Dogs, cats, mice, tortoise.	Dogs, cats, mice, tortoise.	Companionship and exercise.	Other dogs, barking and biting.
Danni	Dog, cat, bird, mice, rabbit, tortoise.	Dog and cat.		Attacked by nursing cat.

Name	Childhood pets	Adult pets	Positive experiences	Negative experiences
Leigh	Dogs, rabbits, fish.	Fish.	Companionship (dogs) and relaxing (fish).	Don't like some animals, e.g., cockroaches and snakes if they are in or around my house.
Mark	Dogs.	Dogs.		
Mary	Dog.	Cat.		
Reggie	Cats.	Cats.	Love and affection.	Chased by vicious dog.
Sam	Dog, cat, bird, fish.	Dog, cat, bird, fish, rat.	Cat was my best friend for 15 years. My dogs protected my son from being run over on a main highway.	My husband shot my dog. I accidentally ran over my mother's dog.
Sharon	Dog and cat.	2 dogs (Maltese), 2 cats (long haired Burmese).	Company, interaction.	Fine hair on the cats caused asthma as an adult (Don't have it with dogs).

Name	Childhood pets	Adult pets	Positive experiences	Negative experiences
Wade	A cat.	A cat and 2 dogs on separate occasions.	A calming, relaxing effect when interacting with them.	When they keep you awake at night.
Wynn timer	Dogs, cats, horses, goats, chickens, geese, pigs.	Communal dogs, cat, Galah.	Most experiences with animals for me have been positive.	Was bitten by a Chihuahua that belonged to my aunt who was staying at our house.

adults. Danni and Mary did not report any positive experiences with animals. The range of comments from the remaining 12 participants suggest that people's positive experiences with animals were characterised by companionship, love, affection and relaxation. Three participants, Andy, Danni and Wynn timer reported being bitten by animals, and together with the range of comments from the remaining 11 participants, the suggests that people's negative experiences with animals were characterised by danger, annoyance at barking and aggression.

Three students, Coral, Leigh, Reggie and Wade, stated that they held fears associated with dogs being present in the classroom, and only two students, Leigh and Reggie stated that they had health concerns. Reggie stated that her fear and health concern was a, "high allergy to animal hair." Leigh stated her fear in terms of dislike

and stated that she, “wouldn’t like it if dog had fleas/ticks or smelt bad or slobbered everywhere.” She stated that her health concern was, “if dog was clean, none.” Coral and Wade stated their fears were, “only minor distraction.” These results suggest that only two students, Leigh and Reggie, held fears and health concerns associated with the dogs being present in the classroom.

Reported in Table 12 is a summary of participants’ perceived advantages and disadvantages of dogs being present in the classroom. Five students, Brad, Danni, Mark, Mary and Reggie did not state any perceived advantages. Along with Andy and Sam, these five students, except Reggie, did not state any perceived disadvantages. Coral, Danni and Wynnie stated that they were unsure of the perceived advantages. The range of comments from the remaining six participants, Andy, Borat, Leigh, Sam, Sharon, and Wade, suggest that the perceived advantages may be characterised by the dogs creating a relaxed, fun, happy environment, and that the perceived disadvantages may be characterised by distraction.

Course Summary

Reported in Table 13 is a summary of the structure of the course including start and finish times for each lesson, the topics taught, the teaching methods used, and identifying the teachers who conducted each lesson.

Observational Data

Classroom observations were conducted for each teaching period, and running records of student, teacher and dog behaviours were recorded directly onto a Microsoft Access database using a laptop computer. A total of 769 observation records totalling 94,336 words were recorded at an average interval of three minutes and 53 seconds. These running records were summarised by plot and sub-plots for each of the main actors, and were coded using emergent coding. When analysed, these codes revealed

Table 12

Perceived Advantages and Disadvantages of Dogs in the Classroom

Name	Perceived advantages	Perceived disadvantages
Andy	Breaks the ice.	None.
Borat	Nothing apart from the study.	Perhaps the concentration, as highlighted in the study.
Coral	Unsure.	Unsure.
Dan	Unsure.	Unsure.
Leigh	Fun.	Bit awkward if you know others don't like dogs.
Reggie	For myself nil - more negative.	Makes me edgy and am allergic to animal hair. Don't know about other people.
Sam	More relaxed and happy environment. Help people to de-stress.	Nil
Sharon	Perhaps bring a calming influence to the class.	Perhaps a distraction.
Wade	Enjoyable learning environment.	Distractions once again.
Wynn timer	No sure, will see after the research.	May be a possible distraction.

Table 13

Course Structure and Outline

Teaching period	From—to	Topic	Teaching method	Teacher
Day 1 Tuesday, 6 February, 2007				
1.1	8.30 am— 9.00 am	Safety induction	Presentation	Sarah
	9.00 am— 10.00 am	Course introduction	Presentation	Tanya
	10.00 am— 10.40 am	Break		
1.2	10.30 am— 1.00 pm	The VET sector	Presentation and assessment	Sam
	1.00 pm— 2.00 pm	Lunch		
1.3	2.00 pm— 3.40 pm	Inclusivity	Presentation	Alma
	3.40 pm— 4.00 pm	Break		
1.4	4.00 pm— 4.20 pm	Inclusivity	Presentation	Alma
	4.20 pm— 5.00 pm	Inclusivity	Assessment	Alma

Day 2 Wednesday, 7 February, 2007

Teaching period	From—to	Topic	Teaching method	Teacher
2.1	9.00 am— 9.30 am	The Vet Sector	Assessment	Sam
	9.30 am— 10.30 am	Training packages	Presentation	Sam
	10.30 am— 10.55 am	Break		
2.2	10.55 am— 1.00 pm	Training packages	Presentation	Sam
	1.00 pm— 2.00 pm	Lunch		
2.3	2.00 pm— 3.25 pm	Assessment plan	Presentation & assessment task lesson	Sam
	3.25 pm— 3.55 pm	Break		
2.4	3.55 pm— 5.00 pm	Assessment role play	Assessment task lesson	Tanya
Day 3 Thursday, 8 February, 2007				
3.1	9.00 am— 10.30 am	Health and safety	Presentation	Alma
	10.30 am— 11.00 am	Break		
3.2	11.00 am—	Health and	Presentation and	Alma

Teaching period	From—to	Topic	Teaching method	Teacher
	1.00 pm	safety	assessment	
	1.00 pm— 2.00 pm	Lunch		
3.3	2.00 pm— 3.30 pm	Moderation and validation of assessment	Assessment	Alma
	3.30 pm— 3.45 pm	Break		
3.4	3.45 pm— 4.15 pm	Moderation and validation of assessment	Assessment	Alma
Day 4: Friday, 9 February, 2007				
4.1	9.00 am— 9.30 am	Moderation and validation of assessment	Assessment	Sam
	9.30 am— 10.20 am	Writing a letter	Assessment task lesson	Sam
	10.20 am— 10.40 am	Break		
4.2	10.40 am— 12.00 pm	Create a flyer	Assessment task lesson and void lesson	Johannes
	12.00 pm—	Planning the	Assessment task lesson	Sam

Teaching period	From—to	Topic	Teaching method	Teacher
	12.50 pm	lesson		
	12.50 pm—	Lunch		
	1.50 pm			
4.3	1.50 pm—	Planning the	Assessment task lesson	Sam
	3.20 pm	lesson		
	3.20 pm—	Break		
	3.45 pm			
4.4	3.45 pm—	Planning the	Assessment task lesson	Sam
	4.00 pm	lesson		
	4.00 pm—	Learning	Presentation	Sam
	4.50 pm	principles		
Day 5 Tuesday, 13 February, 2007				
5.1	9.00 am—	Leigh and	Assessment task	Students
	10.40 am	Sharon's	lesson—student	
		presentations	presentations	
	10.40 am—	Break		
	10.55 am			
5.2	10.55 am—	Danni, Andy and	Assessment task	Students
	12.50 pm	Borat's	lesson—student	
		presentations	presentations	
	12.50 pm—	Lunch		
	1.50 pm			

Teaching period	From—to	Topic	Teaching method	Teacher
5.3	1.50 pm— 2.20 pm	Personality types	Void lesson	Tanya
	2.20 pm— 3.10 pm	Mary's presentation	Assessment task lesson—student presentations	Students
	3.10 pm— 3.30 pm	Break		
5.4	3.30 pm— 4.50 pm	Contextualising learning, barriers and motivation to learning	Presentation	Sam
Day 6 Wednesday, 14 February, 2007				
6.1	9.00 am— 10.20 am	Brad and Wynnie's presentations	Assessment task lesson—student presentations	Students
	10.20 am— 10.45 am	Break		
6.2	10.45 am— 1.00 pm	Morgan, Dan and Mark's presentations	Assessment task lesson—student presentations	Students
	1.00 pm— 2.00 pm	Lunch		

Teaching period	From—to	Topic	Teaching method	Teacher
6.3	2.00 pm — 2.30 pm	Andrea's presentation	Assessment task lesson—student presentations	Students
	2.30 pm— 3.30 pm	Web Site Investigation	Void lesson	Sam
	3.30 pm— 4.00 pm	Break		
6.4	4.00 pm— 5.00 pm	Assessment material administration	Void lesson	Sam
Day 7 Thursday, 15 February, 2007				
7.1	9.00 am— 10.30 am	Assessment material administration	Void lesson	Alma
	10.30 am— 10.50 am	Break		
7.2	10.50 am— 11.30 am	Assessment material administration	Void lesson	Alma
	11.30 am— 12.20 pm	Final assessment Submission and close	Presentation	Tanya

Teaching period	From—to	Topic	Teaching method	Teacher
	12.20 pm— 1.50 pm	Video – The Secret (Byrne, 2006)	Void lesson	Tanya

patterns within the observed behaviour of the dogs, and people's interaction with them that are reported in this section. It also revealed patterns of student, teacher and visitor behaviours that are reported at Appendix K, which the reader is encouraged to examine alongside the results reported in this section. These patterns of behaviours were characterised by lesson types and teaching style, visitors, social behaviours, repeated actions, student voices, teacher voices, student engagement and additional observations. These additional patterns may help to form the answers to the research questions by providing a deeper understanding of the context within which people interacted with the dogs. Additionally, a chronology of the observational data is presented in the temporal maps at Appendix I.

Dog Behaviour and Interaction

The patterns the dogs' behaviour and people's interaction with them were distinguished by three aspects: socialisation, active spontaneous behaviour and passive disciplined behaviour.

Socialisation

One pattern of behaviours that characterised socialisation was distinguished by how people and the dogs were introduced to each other, how people greeted the dogs each day, and how people farewelled the dogs at the end of each day and at the end of

the course. For example, at the beginning of the course the researcher introduced Adonis and his handler to the group and on the morning of the fifth day introduced Buddy and his handler. Lady and her handler were informally introduced to participants by the researcher when they arrived at the beginning of the lunch period on the first day. All students except Brad, Morgan and Reggie, as well as the teacher greeted the dogs when they arrived by patting them, and saying, “hello,” to them and their handlers. In contrast only one student, Danni, said, “hello” to another student, Borat, on the morning of the last day of the course. Similarly only one student, Andrea, said, “good bye,” to the dogs on one occasion. However the teacher said, “good bye,” to the dogs on four occasions. The way students and the teachers greeted the dogs is exemplified in the following extracts from the running records:

8/02/2007 9:01

As they set up, Alma introduces herself, and says today is fairly light on and we might get an early mark. Sharon, Dan, Borat, Wade, Coral and Wynnie all go up to say hello to Adonis before the class starts. They are getting a cup of coffee. Adonis and Alicia are sitting on the left hand side of the dining table, facing the group. Wynnie asks Adonis what type of bandana he had on today, rubs his neck, and makes comments about the bird design.

9/02/2007 9:01

Alicia and Adonis have arrived and a few people have gone up and patted him and said hello including Mark. When Adonis wandered the room initially he went to Borat and Wynnie who said hello to him and patted him.

14/02/2007 9:02

Amanda and buddy arrive, and I greet them as they enter through the reception door, buddy on lead. Wynnie and Danni, stand next to their chairs, organising

their material for the day, and look over and say hello directly to Buddy and make comments. Amanda walks around the front of the room. Sam stands at her desk, looks down and says hello. Amanda and Buddy walk around the open space. Mark goes up and pats Buddy near the couch. Amanda is standing next to Andrea, who is bending down and patting. Sam walks to the coffee table and makes a cup of coffee. Mark is in the middle of the room, and is standing in front of Danni. He talks to Danni, Wynnie and Morgan about a dog his neighbours have, and then he returns to his seat. Amanda sits on the sofa with Buddy next to her.

The morning and afternoon breaks were used by students and the teacher as opportunities to approach and greet the dogs and handlers, and engage in social conversation. The way the teachers and students interacted with the dogs and handlers during these breaks is exemplified in the following extracts from the running records:

6/02/2007 10:05

Sam asks Tanya if it is time to take a break and Tanya tells the group to get some morning tea. Many of the people get out of their chair for morning tea. Wade turns around behind him and pats Adonis. Sharon and Dan walk to the back of the room and say hello to Adonis and move to the front of the room.

7/02/2007 10:05

The office door opens and Sally brings in a plate of sandwiches and sausage rolls and puts them on the dining table. Alicia gets up and takes Adonis over to the exit sign and he reaches his nose forward sniffing the food. Reggie, who is standing, laughs slightly. Andrea looks around with a disappointed and exaggerated frown. Sam breaks the class for morning tea. Wade pats Adonis commenting that he is a barking boy (nicely) and smiling as he says it.

8/02/2007 10:30

When I came back from the break, Leigh, Amanda and Alma were sitting around the table with Adonis, talking about her and Adonis as they ate and drank coffee.

8/02/2007 14:02

When I walk back in from lunch (I interviewed Brad and had Wynn timer and Andy join in the discussion on the tape) I greet Lady and Heather, who tells me that quite a few people have come up to her and said hello to lady.

9/02/2007 10:20

During the break Andrea is standing in front of the dining table, close to the exist door, talking with Alicia, facing towards the wall and occasionally looking out the window.

9/02/2007 10:43

When I come back from the break, Leigh is sitting at the dining table, against the wall, talking with Alicia who has Adonis next to her. I've just taken the plate of food out, and returned to see Mark sitting in the same chair, patting Adonis and talking to Alicia.

Socialisation was also characterised by the way Alma facilitated a brainstorming session with students in an attempt to create a set of agreed ground rules to guide normative behaviour. This set of ground rules did not include the dogs.

Active Spontaneous

The active spontaneous characteristic of the dogs' behaviour and people's interaction with them was distinguished by facets of wandering and initiating, patting and watching, wagging, vocalising, playing, coaxing and commanding, and feeding. The active spontaneous characteristic of the dogs' behaviour was exhibited most by

Adonis, to a lesser extent by Buddy, and only occasionally by Lady, as evidenced by the temporal maps of observational data that are reported at Appendix I.

Wandering and initiating, patting and watching. Wandering and initiating, patting and watching were distinguished by the way Adonis frequently wandered freely around the room and under the tables and became entangled in cords, the way he sniffed at the floor near people's chairs and at the door or people's bags, and the way he directly approached people and nudged their hand or elbow with his nose. During these periods, people smiled as they watched Adonis, and patted him as he wandered past them. The only participants not observed patting Adonis were Brad and Morgan. This characteristic of dog behaviour and interaction is exemplified by the following extracts from the running records:

6/02/2007 10:46

Adonis is lying down in front of Alicia. She gets up and holds him by the collar and leads him as she moves back to her chair. He picks up his bone and wanders around the room and under the table. Andy gives him a pat and he stays with him for a few seconds, and then continues wandering around the front and open space, sniffing the floor for crumbs, occasionally eating a few. As he gets to Coral, Alicia leans forward and pulls him with his collar. Andy is watching Adonis. Dan turns around to see what Adonis is doing. He wanders to Sam who puts her hand down to touch him and goes to the front door. He goes to Sharon who gives him a pat and then he continues wandering up past Coral, Mark and up round the back to behind Wade, and gets a drink. Andy turns to watch him having a drink. Other people have books on the laps and are resting against the desk taking notes. Andy gives Adonis a pat as he wanders around him, and he goes round the open space to my exit door.

Initiating was also characterised by the way Adonis instigated interaction with people, sometimes by retrieving toys and bringing them to people, as evidenced in the following extracts from the running records:

8/02/2007 9:09

Coral looks down slightly to Adonis at her right and smiles and Adonis turns around and points his nose directly at Mark's face. Mark looks down and whispers some words as he continues to pat him. Adonis retrieves his chew bone and brings it in his mouth and holds it up to him.

8/02/2007 9:22

Reggie asks a question of Alma. Adonis appears around the front corner near Andy under the table and goes up to Borat who nestles him between his legs, and reaches down and pats him. Adonis points his nose in Wynnie's lap, who reaches down and pats him. He walks towards me and then rolls on his back on the floor briefly before getting up and sniffing the reception door.

A further characteristic of the dogs' behaviour that distinguished wandering and initiating, patting and watching was when the dogs appeared to play by themselves, as evidenced by the following extracts from the running records:

8/02/2007 9:09

Alma continues talking, standing in front of the laptop, reading from the slides, and picks up some papers and shuffles them. Adonis wanders around the back of the room and towards me, sniffing the floor, he rolls over on the ground behind Brad vigorously. Danni and Wade turn around to watch him as he is making some noise. Danni and Wade have smiles on their faces and Danni turns to her left and makes a quiet comment to Morgan, both smiling.

Wandering and initiating, patting and watching were also characterised by the way people watched or patted Buddy as he wandered freely, the way Buddy looked around the room and jumped up and down from the couch, and the way the handler introduced Buddy to students. The only participants not observed patting Buddy were Brad and Morgan. This behaviour is exemplified by the following extracts from the running records:

13/02/2007 9:06

Dan, Sharon and Mark turn and lean over the back of their chairs to look as Buddy walks past. Amanda walks around the room and sits on the couch and Buddy is jumping up and down on the sofa.

13/02/2007 10:15

Andrea returns to her chair and turns around in her seat looking at Buddy and says its hard work up there. Buddy leaps off the sofa and dashes to Andrea who is smiling broadly, saying she wants one before turning to face the group.

13/02/2007 10:54

Buddy wanders briefly under the desks near Andrea. Leigh clicks her fingers and then Buddy jumps up and puts his front paws on the desk between Andrea and Mark. Dan turns around and leans over the back of his chair and pats Buddy. Amanda continues to talk to Sharon. Buddy jumps up with his front paws on Dan's left leg and he pats and strokes him. Sharon says they are so cute aren't they.

13/02/2007 10:58

Mark, Andrea, Mary and Leigh are looking at their laptops talking quietly to their neighbours. Sam, Brad and Andy are still out of the room. Amanda finishes talking to Sharon and walks around the front of the room, Buddy following her.

She walks around behind Wynn timer who is talking to Morgan, who says, "Hello pups," and leans down and pats him. He puts his paws up on Wynn timer's knee as she talks to him, asking if he came to say hello. She says she thinks he is a superstar and he gets down again. Wynn timer talks to Amanda standing behind her and Morgan looks at them. She is turned in her chair towards the front. Danni is standing next to Leigh's right, her left arm on her hand, both looking down at her laptop screen. Morgan gets out of her chair and walks around the back of the room. Danni walks back to her chair and sits down again. Morgan puts her cup in the bin under the coffee table. Danni is turned in her chair towards the front. Wynn timer is turned in her chair to face Danni and leans down to her left and pats Buddy. She looks down and occasionally up at Amanda and talks about Buddy and his breed. Morgan looks at them, and turns around to face her laptop screen and across at Leigh. Sam who has walked into the room, walks up to Mary and talks to her briefly before going to the coffee machine and makes a cup of coffee. Danni is still leaning down when Sam says that it is Danni's turn to go next. Amanda walks around behind Morgan next to Leigh followed by Buddy, and she gives out a big, "Ooooh." She leans down to her right patting Buddy, who is sitting down, and says, "He is too cute."

Wandering and initiating, patting and watching were also characterised by the way only a few people, Andrea, Leigh, Mark and Sam, watched or patted Lady when she wandered, as evidenced by the following extracts from the running records:

7/02/2007 16:18

Lady steps towards and behind Andrea's chair. Tanya is talking to Andrea. Andrea gently strokes Lady's head. Lady then lies down, looking at Sam who has walked around the room to the coffee table to make a cup of coffee. Tanya

walks between the whiteboard and behind the desk as she continues writing the checklist using comments from the group. Sam sits down next to me on the left at the dining table and reaches down and pats Lady.

7/02/2007 16:31

Sam opens the reception door and walks around the back of the room and when she gets to Lady, pats her gently before sitting down in the chair next to me.

7/02/2007 16:42

Lady gets up and Mark reaches behind him to pat her. Sam gets up and goes around to Borat to get the document off his computer to print it for the others.

Lady steps next to Andrea who strokes her gently.

13/02/2007 14:47

Mary continues her presentation. Lady puts her nose at Sam's left leg, sniffing, and she sniffs the chair to her left before walking around back behind Leigh.

Sam looks down as she pats Lady.

Wandering and initiating, patting and watching were also characterised by the way Alma acknowledged Adonis on only two occasions and patted him on only one occasion, as evidenced by the following extracts from the running records:

8/02/2007 9:09:10

Alma continues talking, standing in front of the laptop, reading from the slides, and picks up some papers and shuffles them. Adonis wanders around the back of the room and towards me, sniffing the floor. He rolls over on the ground behind Brad vigorously. Danni and Wade turn around to watch him as he is making some noise. Danni and Wade have smiles on their faces and Danni turns to her left and makes a quiet comment to Morgan, both smiling. Adonis then wanders around the front of the room. Alma is talking to the group, and looks

down and says, “You can’t go out there doggy.” He continues wandering and reappears in the middle of the desks as Danni and Borat watch him.

8/02/2007 9:28:08

Alma opens the sliding office door and leaves. Adonis walks up to the door, standing just underneath the screen for a brief time. Wynnie gets out of her chair and leaves through the front reception door. Adonis stands just to the right of the screen, looking at the reception door briefly. Leigh gets up and goes to the coffee table and returns. Alma opens the sliding door, re-enters and sits down to find Adonis next to her. She smiles and says, “Oh!” quietly as she puts her hand down and briefly pats Adonis.

Wagging. The active spontaneous characteristic of the dogs’ behaviour and people’s interaction with them was also distinguished by the way Adonis wagged his tail that hit against the floor, desk or chair, which made a noise that students acknowledged by looking towards him, or by making comments. This characteristic was evidenced in the following extracts from the running records:

6/02/2007 11:20

Sam is explaining Mayer key competencies. Adonis lies down behind Coral and Mark, wags his tail a few times, making a noise as his tail hits the floor. Coral turns her head and looks behind her at Adonis briefly.

7/02/2007 9:55

Reggie enters the room through the reception door and walks around the room. She steps over Adonis without looking down, and returns to her chair and begins scrolling through a document on her computer. Adonis wags his tail a couple of times, hitting the floor. Coral and Mark talk briefly about the sound of the tail, Mark moving his hands in a wagging gesture.

7/02/2007 11:08

Coral pats Adonis. Mark re-enters the room through the reception door, walks around the front of the room, and takes his chair, which is slightly angled towards the front. Adonis wags his tail which knocks against the leg of Dan's chair. Dan looks over his left shoulder behind him briefly.

Vocalising. The active spontaneous characteristic of the dogs' behaviour was also distinguished by the way Adonis vocalised through spontaneous barking and whimpering, which appeared to occur either in response to play with students or as a way of initiating interaction with them. This characteristic was evidenced by the following extracts from the running records:

7/02/2007 11:49

Reggie pulls her chair back in and sits down. Adonis walks behind me and stands between me and Alicia and lets out a single bark. Borat gets out of his chair, and walks around the front of the room to the coffee table and fills a paper cup with water, and returns to his seat. Mark looks behind him at Adonis, who is taking a drink from his water bowl and stands there.

7/02/2007 12:19

Mark who is standing up, goes and sits on the couch next to me rubbing Adonis saying that he is a big bully, and asking what is the matter, rubbing him, saying he is a good boy. Coral comes over and says that Mark is a dog seducer. Mark gets up standing next to and slightly in front of my desk and talks with Adonis, says can he speak, and Adonis barks.

8/02/2007 9:49

People are watching Mark as he talks and I can see Adonis behind him. So can others. Adonis gives a small sound. Andrea turns her head again briefly to her

left and smiles as she glances around again. Wade looks over, though I can't tell if he is looking at Mark or Adonis. As soon as Brad starts talking he looks in his direction, and then again when Danni talks. Adonis makes another small sound. He continues wandering around in the open space, sniffing near the fridge. Alicia gets up from her seat and goes to him briefly before sitting down again.

8/02/2007 11:02

A large truck drives nosily past on the road outside. Adonis gives a couple of loud barks, and a few people look around. Mark pushes his chair back and gets up to step across to the coffee machine and makes a cup of coffee.

One of the notable occasions on which Adonis vocalised took place towards the end of the first teaching period on the second day, when Adonis barked at two dogs who walked passed outside the classroom. Shortly afterwards, during the formal mid-morning break, the stray dogs entered the classroom. The following excerpt from the running records provides a detailed account of the event:

7/02/2007 9.52

Reggie pushes her chair back and stands up behind her chair. A couple of dogs walk past the exit door outside. Adonis' handler and I exchange a few comments, saying she was ready to grab Adonis. Reggie reaches for a bottle of water from the desk. The dogs outside pause at the door and look in. Mary, Reggie, Leigh and Wade, look outside briefly, smiling and laughing lightly. The dogs move on. Andy returns through the reception door, taking his seat and starts writing. Reggie walks around the front of the room and leaves through the reception door. Wynn timer, Danni and Morgan are talking, Borat leaning towards them listening as he works on his computer, laughing occasionally.

7/02/2007 10.05

Sam was bending over the desk near Borat. As Adonis saw the dogs he barked loudly many times and charged towards the door. His handler quickly grabbed him by the collar restraining him. The dogs outside (one very small terrier type, and one large Dalmatian ridgeback-type cross) barked aggressively at Adonis through the door. I can't remember who barked first, but it was only a split second between the first exchanges. Adonis barked loudly for several minutes and the room felt charged. Everyone immediately focused on the chaos. I pulled the curtain back across the door. A couple of people got out of their chairs, and walked over to the coffee table. Soon, people were disorganised, leaving the room, or going over to get a cup of coffee. Mark, Sharon, Danni, Borat, Andy, Wynnie in particular came over to get a cup of coffee and patted and talked to Adonis, pausing to spend a few minutes, saying, "Did they get you excited?" People came over in twos and threes, not all at once. In the middle of it all Sam continued providing help to someone at their desk. Someone opened the door and called to Dan to say he had a phone call. It appeared that the group had initiated their own 'break'.

7/02/2007 10.13

The group has just settled down with everyone back in their seats. Wynnie came back into the room, to say that the dogs were now in the reception area. The door was open after Dan went out to get the call. Mark came over to say that the dogs were still outside as well. Sam, who had not stopped providing help to someone (can't remember who) on the other side of the room, went back to her desk and sat down at the front of the room. She got up shortly after, and walked up around the open area and then patted Adonis, talking to him briefly about how he got excited. She then continued talking to the group.

7/02/2007 10.20

Adonis barks again as the dogs are obviously outside. Sam continues her presentation, sitting at the front desk. Adonis' handler pulls him back and he quickly settles back down, lying next to her. She puts the lead on Adonis when she found out the dogs were in the reception area.

7/02/2007 10.25

The office door opens and Sarah brings in a plate of sandwiches and sausage rolls and puts them on the dining table. Adonis' handler gets up and takes Adonis over to the exit sign. He reaches his nose forward sniffing the food.

Reggie, who is standing, laughs slightly. Andrea looks around with a disappointed and exaggerated frown. Sam breaks the class for morning tea.

Wade pats Adonis commenting that he is a barking boy (nicely) and smiling as he says it. After the event, when people broke for morning tea, I went outside to ask the reception girls if they knew anything about the presence of the two dogs.

They said they were strays who had only just appeared in the area today, and that they were thinking of calling the RSPCA. Narelle told me there were out

the back in the yard area they have out there. I went outside and saw the two

dogs. Borat was there, and Reggie came out and a few others as well. The dogs

were wandering in the yard. I thought at the time that was okay, as they

wouldn't be out front where Adonis could see them. Borat told me that he might

be interested in taking them home. Reggie, who pats the dogs, and Narelle and I

agreed that they didn't have collars so she should call the RSPCA. I came back

into the room, and spoke to Adonis' handler, who had Adonis on the lead.

Shortly after that I saw Tanya had come into the room. The two dogs had got

into the classroom. Alicia restrained Adonis as other people tried to capture the

two dogs. After Narelle had taken them out, she said she was taking them home. Adonis barked when they left. Tanya gave Adonis some food. Adonis' handler says that she is concerned that Adonis will not be allowed back.

7/02/2007 10.53

People have finally reformed from the break.

Playing. The active spontaneous characteristic of the dogs' behaviour and people's interaction with them was also distinguished by the way two students, Andy and Mark played with Adonis. For example, on one occasion Mark, who was seated in his chair, played with Adonis by offering his hand, and on another occasion he walked over to the couch where he played with him for several minutes. This characteristic was evidenced by the following extracts from the running records:

6/02/2007 12:15

Sam is standing at the front, leaning against the chair and asks people if they have had experience with an audit. Borat and Coral offer some comments.

Adonis goes up to Mark with his lead. Mark is turned in his chair and reaches over with his left arm and pats him, Adonis is trying to playfully bite his hand. Coral leans over her right hand side and looks at them playing. Mark puts his arm over Adonis and down his side, gently stroking and patting him. He offers him his finger to bite. When he stops, Adonis puts his nose towards Mark and whimpers. Mark whispers a comment. Coral leans over her right side and looks at them.

7/02/2007 12:19

Mark who is standing up, goes and sits on the couch next to me rubbing Adonis saying that he is a big bully, and asking what is the matter, rubbing him, saying he is a good boy. Coral comes over and says that Mark is a dog seducer. Mark

gets up standing next to and slightly in front of my desk and talks with Adonis, says can he speak, and Adonis barks. They are both smiling. He gives his finger which Adonis bites and then barks louder. Wynn timer gets out of her chair and comes over to get a cup of coffee and pats Adonis, talking gently with him as he stands next to Alicia who is sitting down in her chair.

Andy played with Adonis on one occasion during the second teaching period on the fourth day when Sam sat in front of Andy's computer and completed an exercise for him as Brad watched. Andy, who had walked over to the coffee table to get a cup of coffee, reached down and patted Adonis. He then began ten minutes of play which was evidenced by the following extracts from the observation records:

9/02/07 11.31

Andy crouches down and pats Adonis as he sips his coffee. Adonis standing in front of him and Adonis barks several times. Johannes returns to the front of the desk, leaning over, and uses the computer and talks. Andy is looking down at Adonis in front of him as he sips his coffee. Adonis lifts his nose to Andy's face, Andy lifts his nose as well, looking at him and Adonis barks again. Andy walks around behind Johannes and crouches down against the wall to the right of the big screen, followed by Adonis, patting him as they talk. Adonis stands in front of Andy, as he continues patting, sipping his coffee. Adonis barks again.

Wynn timer turns around in her chair to her right and looks at Andy asking what are you doing to the dog, you're tormenting him. People turn their heads and look over at Andy as he says that he's not. People return to their document. Johannes sitting down at the front desk operates the computer and creates a document. People work quietly. Andy remains crouched against the wall. Adonis lies down behind Brad's chair, facing towards Andy.

9/02/07 11.36

Andy sits down against the wall, his left knee raised and his left arm resting on it. He reaches his left arm out and waves his fingers in the air in front of Adonis briefly. Adonis turns to chew at his leg. Andy leans forward and kneels on one leg. Bending over the desk, he talks quietly with Sam. Johannes stands up and steps to the right side and slightly behind Sharon, pointing at the screen and talking with her quietly. He steps back to his desk and sits down, talking as he looks at his screen, and operates his computer. Adonis gets up and walks around behind Andy. Standing on Andy's left, he puts his nose under Andy's arm, who then puts his arm over him as he lets Adonis lick up towards his face. Sam turns and looks down towards Andy, who looks at the screen on the desk. Both nodding. Adonis makes a small whimper. I can hear him scratching. He is standing between Johannes and Andy. Andy is turned to his right facing Adonis. Adonis takes a few steps and stands behind Andy.

9/02/07 11.41

Sam gets up, bends down and pats Adonis. Andy stands up and resumes his seat in the chair.

Coaxing and commanding. The active spontaneous characteristic of the dogs' behaviour and people's interaction with them was also distinguished by the way students purposefully coaxed the dogs by clicking their fingers and calling their name. This was evidenced by the following extracts from the running records:

7/02/2007 9:32

Sam continues her explanation and moves between the whiteboard to add to the diagram and the front desk. Adonis walks to Leigh and then under the desks.

Sam says, "Adonis, you really like getting under there don't you?" Coral silently clicks her fingers coaxing Adonis out from under the table.

8/02/2007 9:06

Adonis appears from around the front of the room. Andy gives him a pat. Borat stretches his right arm out behind the desk, coaxing Adonis towards him. He comes to him and he pats him. Adonis wanders around back to Andy who reaches down and pats him, and then wanders under the table and comes out near the exit door. He wanders around the open space.

8/02/2007 10:10

Adonis wanders around the back of the room, past me and pauses at Andy's chair. His lead is on and he is carrying it in his mouth. He sniffs at Reggie's feet. Alicia looks up at me, and starts to get out of her chair. I look at her and nod an okay expression. Borat reaches for Adonis' lead and draws him close to him and pats him briefly. Reggie walks around the front of the room behind Alma back to her desk, followed by Adonis. Borat tosses his lead over Adonis' back.

13/02/2007 9:47

Something drops on the floor in front of Sharon. As Sharon stands, Sam turns to her right and says, "Buddy fetch." Sharon and Dan turn and look around at Buddy.

13/02/2007 10:54

Buddy wanders briefly under the desks near Andrea. Leigh clicks her fingers and then Buddy jumps up and puts his front paws on the desk between Andrea and Mark.

Coaxing was also distinguished by the way students crackled plastic bottles and papers that unintentionally coaxed the dogs, and this was evidenced by the following extracts from the running records:

6/02/2007 11:09

Sam continues her presentation, explaining what RTOs are, standing in front of the front desk. People are looking towards the front of the room. Mark is crackling his water bottle, sitting sideways forward in his seat. Adonis gets up and puts his nose to the bottle making the noise. He sits down next to and slightly behind Mark who pats him for several minutes. He gets up and comes to me and I give him a pat. Mark crackles his bottle again and Adonis goes back. He takes the label from the water bottle in his mouth and drops it on the floor. Mark is turned in his chair and is watching.

7/02/2007 11:49

Adonis wanders round the back of the room to Mary who has crackled paper opening a mint. She gives him a pat, with Alicia watching him.

7/02/2007 11:55

Sam continues scrolling through the document. Wynnie reaches over for a mint, crackling the paper. Adonis gets up from my side and wanders around near the exit door and couch, sniffing the floor.

9/02/2007 10:46

Sitting, Sam continues to talk to the group. Adonis wanders under the table towards Danni as she opens the packet of chocolates and crackles the paper. Danni and Morgan talk, commenting that Adonis wants the chocolates/ Danni moves her chair back, calling Adonis and coaxing him out. Johannes stands up and steps back briefly facing towards Adonis, and he looks down as well. They

coax him out and he wanders around the front of the room behind Sam and into the open space in front of the fridge.

Coaxing and commanding were also distinguished by the way students gave instructions to the dogs and the way one student, Reggie, during the fourth teaching period on the third day, clicked her fingers as a way to encourage Lady to move away from her. These behaviours were evidenced by the following extracts from the running records:

7/02/2007 12:19

Mark who is standing up, goes and sits on the couch next to me rubbing Adonis saying that he is a big bully, and asking what is the matter, rubbing him, saying he is a good goy. Coral comes over and says that Mark is a dog seducer. Mark gets up standing next to and slightly in front of my desk and talks with Adonis, says can he speak, and Adonis barks.

8/02/2007 14:39

Sitting, Alma talks and explains key competencies. Reggie starts to pace again between her desk and the whiteboard, back to her desk, around to the bookcase and back to her desk. Standing, she looks across to Heather and Lady and clicks her fingers. She picks up her book from the desk and sits down on her chair, which has been pushed back. I look over at Heather, who returns my glance. Reggie looks down at her book, and glances across at Lady again. I can see Lady's legs under the desks. She is walking around in the open space to the right of Heather and in front of and slightly to the left of Reggie. Helen looks across at me again seeking reassurance. Alma continues the discussion and document filling in this fashion. Andrea reaches over her chair with her left hand behind her and I can see she gently pats Lady. Reggie gets out of her chair and paces

again behind Leigh, Mary and Wade and pauses at the bookcase before walking back in front of her computer. Coral talks. Reggie glances down to the floor near Heather. She has a strained expression on her face.

8/02/2007 15:44

During the break I asked Heather what happened when Reggie clicked her fingers. She explained that Reggie has told her that she likes dogs, but that she is allergic to them. Heather had to pull Lady away when she went up to Reggie, which was often as Reggie was pacing a lot. Heather said she wasn't angry, but was very matter of fact and polite about it. She said she was worried yesterday when she saw Reggie, her facial expressions and body language. Just the look of her said to Heather that, "You don't want us to be here." She said that she felt a lot better now that Reggie had spoken to her. Reggie clicked her fingers once when Heather wasn't quick enough to pull Lady away. Reggie was telling Lady to go away. Heather said that occasionally Reggie would double back rather than walk past Lady when pacing the room. Some of the others who got up during the class were okay and gently patted lady.

13/02/2007 9:47

Something drops on the floor in front of Sharon. As Sharon stands, Sam turns to her right and says, "Buddy fetch." Sharon and Dan turn and look around at Buddy.

Feeding. The active spontaneous characteristic of the dogs' behaviour and people's interaction with them was also distinguished by the way one student, Andy on two occasions after asking permission from Adonis' handler, fed Adonis a mint. This was evidenced by the following extracts from the running records:

7/02/2007 12:01

Adonis gets up and wanders around the front of the room to Andy who looks over to Alicia. She says it is okay to give him a mint. Coral gets up and goes to the front of the room. Andy drops an unwrapped mint on the floor, which Adonis is licking and chewing. He reaches down and offers it to him several times. Morgan gets up and goes to the front to get her printing and goes back to her chair. Reggie gets out of her chair and walks round the front of the room and leaves through the reception door. Sam walks around the front of the room and leans over to Andrea, her hand resting on the back of Mark's chair. Alicia gets up and walks around the front of the room and checks on Adonis who is licking the mint near Andy.

8/02/2007 12:23

Alma walks around the room and stands leaning over Danni pointing at her computer. They are talking about competencies. Coral gets up and leaves the room. Andy goes up and gets a mint from the coffee table and returns to his seat, but stands up as Adonis is sitting beside him. He unwraps the mint and gives it to Adonis. People are walking in and out of the room. Andy sits down and gives Adonis a pat as he licks his mint. Andy says, "We should give him tic tacs."

Passive Disciplined

The passive disciplined characteristic of the dogs' behaviour and people's interaction with them was distinguished by the dogs lying down and sleeping, sitting on the coach, standing at the door and looking out, by people stepping over the dog, incorporating the dog into their presentations and exercises, and talking to and about the dogs. The passive disciplined characteristic of the dogs' behaviour was exhibited most

by Lady, to a lesser extent by Buddy, and occasionally by Adonis. This was evidenced by the temporal maps of observational data that are reported at Appendix I.

Laying and sleeping. Laying and sleeping were distinguished by the way Adonis interrupted his episodes of wandering and initiating with periods when he lay down awake, next to people's chairs. On occasion he lay down asleep. This behaviour was exemplified by the following extracts from the running records:

7/02/2007 9:07

Sue is pointing to the screen that has details of what is needed on the diagram.

Adonis is lying down in front of Alicia chewing a rawhide bone.

7/02/2007 9:40

Sitting at the front desk, her left elbow resting on the desk, hand at her chin,

Sam instructs people to click on certain links on the website, Adonis wanders in the open area, pausing to sniff the ground. Alicia walks after him, pulling him back when he starts to head under the table near Reggie, and then returns to her seat. Adonis wanders in the open area and settles, lying down behind Coral's chair, his back against the legs of her chair, his head facing Alicia.

7/02/2007 11:05

Sam is still talking to the group, discussing with them about assessment. Andy is asking a few more questions. Adonis is lying down, napping now in the same spot. He then gets up again and starts sniffing the floor. He walks to the exit door, and stands looking out through the small parting in the curtain.

7/02/2007 11:21

Adonis is still asleep with his back against the legs of Coral's chair.

7/02/2007 11:57

People are reading their documents on the screens in front of them. Adonis comes around behind me, and walks towards the back of Sharon's chair, and then lies down. Alicia who has returned to her chair, had pulled him back saying that she didn't want to get dog hair on Sharon's jacket. Dan has his phone to his ear again. Mary and Wade are talking quietly, smiling and quietly laughing. Adonis lies down behind Dan, facing towards Alicia.

Laying and sleeping were also distinguished by the way Lady frequently lay down asleep for extended periods next to her handler or students' chairs. This behaviour was exemplified by the following extracts from the running records:

6/02/2007 14:39

Andy and Borat leave the room. Brad is reading some material, looking down. Lady lies down behind Andrea, pointing toward Heather. Andy briefly returns and gets something from his desk or bag and leaves the room again through the reception door. Mark moves his chair back slightly so that the legs are against Lady.

6/02/2007 14:44

Mark pushes his chair back and nudges against Lady. He gets up and goes to the coffee table and makes a cup of coffee.

6/02/2007 14:46

Lady is still lying down, eyes open, behind Mark's seat, which is pushed back, pointing towards me.

6/02/2007 14:52

Johannes opens the door and re-enters the room, walks down the side and takes a seat at his computer, which he starts using. Lady sits down facing outward

towards the exit door. She looks outside the door, and then lies down along the door, looking outside.

6/02/2007 15:07

Alma thanks the group. Wade asks a question of Alma. Lady is still lying across the exit door asleep.

6/02/2007 15:26

Lady is still asleep across the exit door.

6/02/2007 15:33

Lady puts her head down pointing towards Heather.

6/02/2007 16:01

Lady lies down behind Mark's chair, in front of Heather, panting, head towards me.

6/02/2007 16:15

Lady walks back to the exit door, and lies down again, still panting slightly.

Alma reads from her laptop off the next slides.

6/02/2007 16:34

The assessment continues in this fashion. There is a banging noise from Borat's side of the room. Lady gets up and looks around. She walks to the back near Leigh briefly and walks back in front of Heather. She stands for a few moments, before lying down behind Mark and Andrea, who has her chair angled towards the front.

Laying and sleeping were also distinguished by the way Buddy sat on the couch for extended periods and intermittently sat up and looked around the room. These periods were occasionally interrupted by brief episodes when students approached

Buddy and patted him or when they coaxed him towards them. This behaviour was exemplified by the following extracts from the running records:

15/02/2007 9:41

Mark gets out of his chair and walks beside me on the right side and stands in front of Amanda. He bends over, talking to her, rubbing Buddy's ears as he does so. Alma gets out of her chair and steps to her left. Stepping on a plastic cup, bends over, picks it up and walks over to the bin on my left and puts it in. Mark and Amanda are talking about people they know. Mark rubs Buddy's ears.

Andrea is playing solitaire on her laptop. Mark returns to his seat. Amanda says, "It's a small world."

15/02/2007 10:02

Andrea and Amanda turn around to look at the sofa at Buddy. Amanda calls him over. Sitting in front of Amanda who is crouched on the ground, Andrea leans over the back of her chair and pats him, saying he is lovely.

15/02/2007 10:04

Andrea has her hand over the back of the chair, and is turned in her seat and occasionally looks down at her right side. She pats Buddy, rubbing his head.

15/02/2007 10:09

Buddy is sitting next to the couch on my right. Andrea turns around and says, "What are you doing over there? I want your attention." Buddy walks over and briefly jumps up on Amanda's legs before walking back and jumping on the sofa. Amanda and Andrea are talking about Buddy. They occasionally look over, and they are talking, laughing. They look over at Buddy. Morgan is watching Andrea and Amanda as they talk, smiling slightly. Andy returns

through the reception door briefly, walks over to his desk and picks up a piece of paper before leaving through the reception door, closing it behind him.

15/02/2007 10:12

Andrea has her hand down behind her chair, rubbing Buddy's ears.

Standing at the door. The passive disciplined characteristic of the dogs' behaviour was also distinguished by the way Adonis and Lady occasionally sat next to the rear exit door and looked outside the classroom. This characteristic was evidenced by the following extracts from the running records:

6/02/2007 11:16

Adonis gets up and stands in front of my exit door. Alicia gets up and stands next to him in front of, to the side of the exit door. Adonis stands looking out the door.

6/02/2007 14:52

Johannes opens the door and re-enters the room, walks down the side and takes a seat at his computer, which he starts using. Lady sits down facing outward towards the exit door, looks outside the door, and then lies down along the door, looking outside.

6/02/2007 15:10

Coral makes a further comment. Mark gets out of his chair and fills his bottle with water. Lady is lying in front of the exit door, next to Heather on the chair, and looks out the door.

6/02/2007 15:16

After finishing her discussion on Johari Window, Alma returns to her chair in front of her laptop, and asks how people can gain information from others about ourselves without inviting criticism. Lady is still looking out the exit door.

7/02/2007 11:05

Sam is still talking to the group, discussing with them about assessment, and Andy is asking a few more questions. Adonis is lying down, napping now in the same spot. He then gets up again and starts sniffing the floor, walks to the exit door, and stands looking out through the small parting in the curtain. He stands there for a few seconds and then continues sniffing the floor and comes up to me, sniffing my leg and I give him a pat.

7/02/2007 14:58

The room is quiet for a few minutes. Sam scrolls through her document, and others type material into their own documents. They are typing up an Assessment Plan. A car door closes outside. Lady gets up and walks to the exit door, looking out with her nose pushing open the closed curtain slightly.

Heather puts her hand down and strokes her back.

Stepping over. The passive disciplined characteristic of the dogs' behaviour and people's interaction with them was also distinguished by the way several participants stepped over the dogs. This was evidenced by the following extracts from the running records:

6/02/2007 14:49

Reggie opens the door and re-enters the classroom, walks around the front of the room, and steps over Lady. She glances down as she steps over her, but there is no real expression on her face.

7/02/2007 9:42

Coral puts up her hand. Sam gets up and walks around the open space and leans over the back of Coral's desk, pointing at the screen, leaning with her left hand on the back of the chair, stepping slightly over Adonis. Many people are now

talking with their neighbours and within their triad groups from yesterday, i.e., Andy, Brad and Borat; Wynn timer, Danni and Morgan, etc. Sam returns to her front desk sits down and asks how people are going. Leigh says that she needs help. Sam gets up from her chair again, and walks around the open space, stepping over Adonis. She leans over Leigh's desk, and then steps between Mary and Leigh, talking and looking at Mary's screen.

7/02/2007 9:55

Reggie enters the room through the reception door and walks around the room, stepping over Adonis without looking down. She returns to her chair and begins scrolling through a document on her computer.

9/02/2007 9:29

Dan and Sharon are leaning inward to each other, looking at a piece of paper Dan has held up between them. He is talking to her. Mark steps over Adonis and returns to his seat.

Incorporation. The passive disciplined characteristic of the dogs' behaviour and people's interaction with them was also distinguished by the way four participants, Andy, Mark, Sam and Sharon, incorporated the dog into their presentations and exercises, either by explicit or implied reference. For example, during Morgan's presentation, students were engaged in a discussion about immunisation and the prevention of diseases in children when Andy and Sam made indirect references to dogs. This was evidenced by the following extracts from the running records:

14/02/2007 11:08

Morgan asks people to answer the assessment questions on the sheets she has handed out. Andrea asks a question to clarify what they are expected to do.

Andy asks about cold sores. Wynnie and Sam make a few comments. Morgan is turned towards Andy, waving her hands in front of her, looking at Andy. She talks to him explaining how cold sores can be transmitted amongst children. "Fleas?!" exclaims Sam, sitting in Morgan's chair. Dan puts his hands on his head. So does Sharon. Danni asks a question briefly of Morgan.

14/02/2007 11:16

Dan leans across and whispers to Sharon. Both are laughing. Morgan continues talking, leaning her arms against the back of the chair. She looks at Dan who had asked a question about immunisations. Andy briefly says it's the same as dogs. Debbie asks about religious beliefs and immunisation.

The second occasion was during Dan's presentation. He handed out large sheets of paper to people who had formed small groups, and asked them to complete an exercise that involved brainstorming and drawing a safety inspection scenario. The drawing from Mark's group revealed a picture of a dog as a safety consideration. The third occasion took place during Sharon's presentation when she included pictures of dogs. This was evidenced by the following extracts from the running records:

13/02/2007 10:05

Sharon returns to the coffee table and makes a cup of coffee. She displays the first slide of her presentation titled, *Communicate Information to Personnel MNMC202A Communicate in the Workplace*. There is a large picture of a small Buddy type dog with his mouth wide open on the opening slide. There are a few laughs.

13/02/2007 10:06

Sharon stands in front of the laptop. She talks to the group, reading from a set of papers she is holding in front of her with her left hand. Johannes briefly enters

the room through the front reception door, and walks over to the coffee table.

Sharon makes a safety comments to watch out for hazards that include cords and our new dog. A couple of people laugh slightly.

13/02/2007 10:08

Sharon continues talking frequently looking down at the pieces of paper in front of her. She stands slightly towards the left of the screen and says that the dog is her assistant at work. He is alerting her that an email has just come in. Wynnie and Danni laugh, and a few people smile. Danni puts her face briefly into her hands.

13/02/2007 10:26

Sharon turns the next slide, holding the pieces of paper at her chest with her right hand. She stands between the whiteboard and desk, talking and asking questions of the group. She turns to look between the large screen and looking at the group. Sam and Andy respond. There is a small picture of two Buddy type dogs looking up and outwards to the group, on the bottom right hand of the screen next to, "Thank you for listening and don't forget to fill out the feedback sheet."

Talking to and about. The passive disciplined characteristic of the dogs' behaviour and people's interaction with them was also distinguished by the way teachers and students spoke to or about the dogs. For example, when talking to the dogs, students made comments and asked questions such as, "Hello," "It's not for puppies," "That's my lunch," "What's the matter?" "You've just woken up," "Are you a happy puppy?" "You're a nice dog," "Did you come to say hello?" "What's wrong, did I stop patting you," "What kind of bandana do you have today?" "What are you doing over there, I want your attention," "When are you coming back." Talking about

included talking to the handler and other students about the dogs' breeding and upbringing, their work for Delta Society Australia, their physical attractiveness, the strength and sound of their tail, the dogs wanting food, asking where the dog was, and sharing personal stories about the students' own dogs. From these conversations, two students, Leigh and Andrea, discovered that they shared mutual acquaintances with the handler.

The teacher made comments when talking to the dogs, about the dogs' behaviour such as, "You really like getting under there," "You can't go out there doggy," "and there goes Lady, you're not going without me mum," and "when are you coming back?" Sam also spoke to the handler about the dogs and recited personal stories about her own dogs. Alma spoke to Adonis on only one occasion. This was at the beginning of the first teaching period on the second day when she said that, "you can't go out there doggy."

Reported at Figure 3 is the number of occasions that teachers and students spoke to and about the dogs. Reported at Figure 4 is the frequency of these behaviours across each of the teaching periods. The comments made by students when talking to and about the dogs, appeared to imply latent messages that seemed to convey their thoughts and concerns. This was evidenced by the following extracts from the running records:

7/02/2007 15:26

Heather made a comment to Coral that Lady is only active when there's food. Coral says that it is more active than they have been in the past hour. [This may indicate that Coral had a preference for an active learning style that was not being met.]

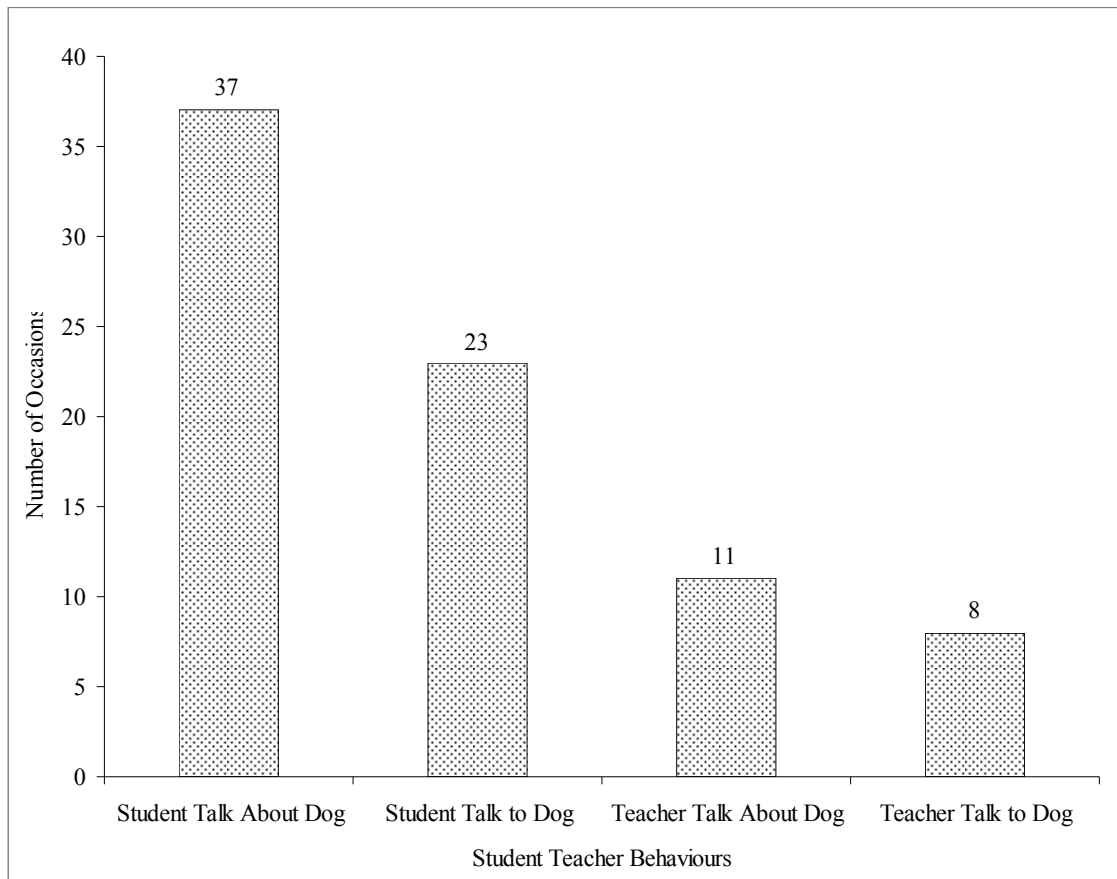

Figure 3. Number of occasions that participants talked about and to dogs.

9/02/2007 12:40

She stands up and looks across to Alicia saying, “Bye bye Adonis.” Andy pats him as he walks, Danni says he’ll be glad to get outside and run around.

Someone else says that they will be too. [This may indicate that the student was not stimulated and sought more active engagement.]

9/02/2007 13:54

Heather arrives with Lady through the exit door. Wynnie calls out and says, “Hello Heather, hello Lady,” and asks her [Lady] if she is looking forward to the weekend. [This may indicate that Wynnie was looking forward to finishing the week’s lessons.]

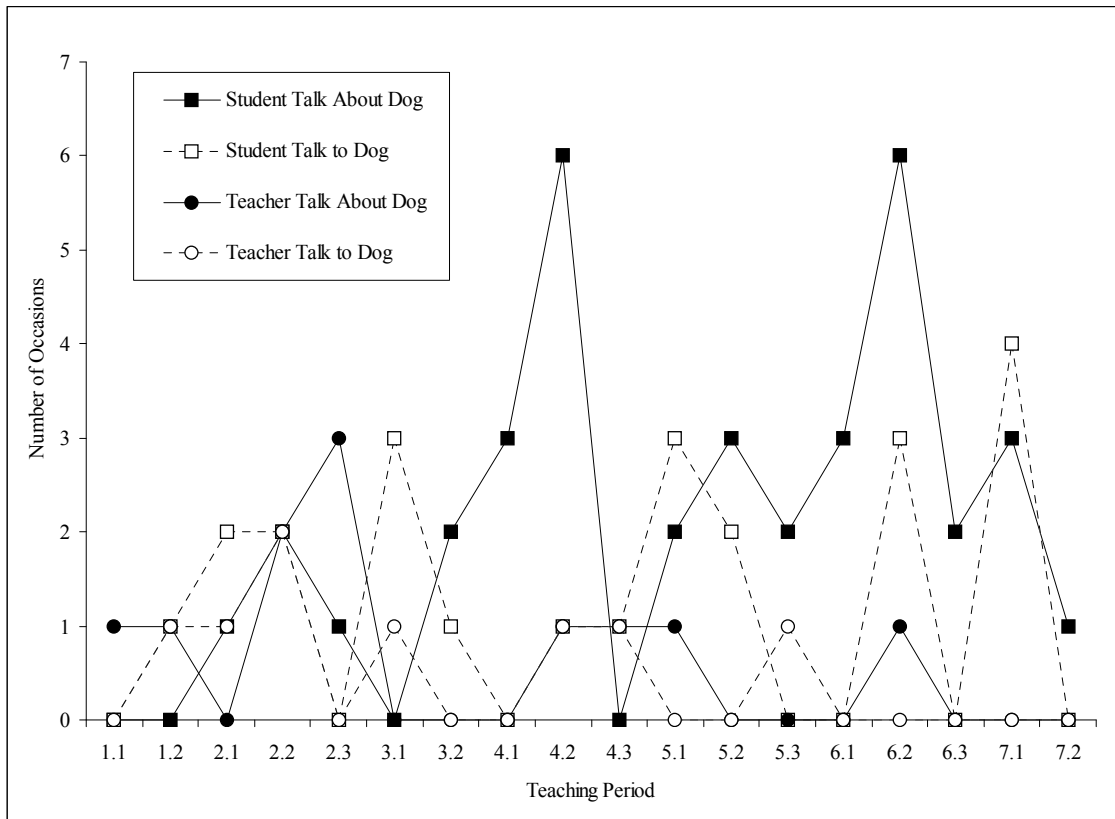

Figure 4. Frequency of participants talking about and to dogs.

13/02/2007 9:33

Brad, Danni and Mary each get out of their chair again and go to the desk with paper. Wynnie says that this is fun and that they have something to do. Morgan adjusts a tie on her shoulder. Wynnie again says that this is fun. I hear her say that she wants to play with the puppy. She continues to talk with Danni and Morgan who are turned inwards. [This may indicate that Wynnie was stimulated by active engagement.]

13/02/2007 10:15

Andrea returns to her chair and turning around in her seat and looks at Buddy. She says its hard work up there. Buddy leaps off the sofa and dashes to Andrea who is smiling broadly. She says she wants one before turning to face the group. [This may indicate that Andrea found the student presentations difficult.]

13/02/2007 12:49

The group has reformed after lunch. Heather and Lady have arrived. Heather and Lady sit in the corner next to and behind Leigh. She puts papers on the floor next to her. She leans down, pats Lady and asks, "Lady, are you going to help me out?" [This may indicate that Leigh was seeking assistance.]

13/02/2007 14:37

Heather is talking across Morgan to Danni. Danni looks down at Lady, talking about how she goes to nursing homes and they she can probably recognise that they [the students] are just stupid adults. [This may indicate Danni's low self-efficacy in the classroom.]

15/02/2007 10:29

People get out of their chairs. Leigh bends down and pats Buddy as she fills a glass of water. Mark is talking to Andrea and says, "get out and walk the dogs." [This may indicate that students were not stimulated and sought more active engagement.]

15/02/2007 11:27

Alma briefly leaves the room through the reception door, closing it behind her. Andy gets out of his seat and walks around the open space, standing next to me and looks across at Buddy. He asks Amanda what his name is. He calls Buddy's name saying that he is going outside with him. Amanda, sitting on the sofa says he won't go outside without her. [This may indicate that Andy was not stimulated and sought more active engagement.]

Similarly, the comments made by Sam when talking to and about the dogs, appear to imply latent messages that seemed to convey her thoughts and concerns. This was evidenced by the following extracts from the running records:

7/02/2007 12:31

Sam comes over to get a cup of coffee, saying that she'll take a break whilst people are finishing off. Adonis and Alicia are standing next to Alicia's chair. Sam pats Adonis and says that it was good that he was here as he provided some light comic relief as this is really heavy stuff. [This may indicate that the teacher was aware of students' cognitive load.]

7/02/2007 15:26

As a joke, Sam says to people around the coffee machine that she always gets a positive response from dogs so she must be a bitch. [This may indicate the teacher's low self-efficacy.]

7/02/2007 16:42

Lady is looking out the exit door whilst Sam is outside. Sam opens the exit door again and returns. Heather gets out of her chair to let Sam in. Sam says that Lady got stressed out when she left. [This may indicate that the teacher was experiencing anxiety.]

7/02/2007 16:46

Sam goes in and out of the room a couple of times to get the printing. Sam says that Lady gets stressed out when she leaves the room. [This may indicate that the teacher was experiencing anxiety.]

9/02/2007 11:04

Adonis is standing next to Andy. Sam leans down and pats him and asks, "What's wrong, do you want to go outside? You're bored, you've had enough exploring." She pats him again and stands up, leaning against the back of Andy's chair with her left hand, alternating between looking at the screen. [This

may indicate that the teacher was aware of students' cognitive load, lack of stimulation and preference for active engagement.]

Interview Data

Reported at Table 14 is a summary of student and teacher participation in event and post-course interviews. Many of those who participated in event interviews also participated in post-course interviews. Dan, Sharon and Andy were unavailable for event interviews despite having previously agreed to participate. Coral, who attended only the first three days of the course, was not available for the post-course interviews. Mark did not attend despite rescheduling twice, and did not respond when subsequently contacted.

Each event interview lasted between 20 and 45 minutes. Post-course interviews, which were combined with the repertory grid technique, lasted between 60 and 120 minutes each. A total of approximately 20 hours of interview data was recorded and transcribed into a text of 124,865 words that was analysed using emergent coding. These codes revealed the pattern of domains and related elements presented at Table 15. These codes also revealed patterns of facets within several elements, a number of which were also characterised by a set of defining attributes. For participants, these domains, elements, facets and attributes characterised the way people interacted with the dogs and the meanings they derived from them, which are reported in this section.

The analysis of emergent codes also revealed patterns of domains and related elements, facets and attributes presented at Table 16 that characterised the environmental context within which people interacted with the dogs. These further patterns are reported at Appendix L, which the reader is encouraged to examine alongside the results reported in this section. These patterns may help inform the

Table 14

Summary of Interview Participation

Name	Event interview	Post-course interview
Alma	Declined	Declined
Andrea	Declined	Declined
Andy	Unavailable	•
Brad	•	•
Borat	•	•
Coral	•	Left early
Dan	Unavailable	•
Danni	•	•
Leigh	•	•
Mark	•	No show
Mary	•	•
Morgan	•	•
Reggie	Declined	Declined
Sam	•	•
Sharon	Unavailable	•
Wade	Declined	Declined
Wynnie	•	•
Total	10	11

Table 15

Taxonomy of Domains and Characteristics of Dog Interaction

Domain	Element—facet—attribute
Physical domain	Dog interaction in the physical domain
Cognitive domain	Dog interaction in the cognitive domain
	Attentiveness
	Arousal
	Refresh
	Distraction
	Blindness
Affective domain	Dog interaction in the affective domain
	Emotion
	Amusement
	Anxiety
	Arousal
	Calm
	Enjoyment
	Emotional climate
	Motivation
	Empathy
Social domain	Dog interaction in the social domain
	Appeal
	Bond

Domain	Element—facet—attribute
	Energy
	Physical
	Handler
	Sociability
	Initiator
	Behaviour
	Personality
	Eye contact
	Human agency
	Desire
	Effort
	Opportunity
	Social hierarchy
	Pretence and conspicuousness
	Behaviour of others
	Normative behaviour
	Authority
	Enculturation
	Breed
	Regional
	Personal
	Technology

Domain	Element—facet—attribute
	Social axioms
	Socialisation

answers to the research questions by providing a deeper understanding of the context within which participants described characteristics of their interaction with the dogs.

Dog Interaction in the Physical Domain

Five students, Brad, Borat, Coral, Danni and Mary, described facets that characterised their interaction with the dogs in the physical domain. For example, Borat described how having to walk around other people was, “like barrier between me and the dog.” Similarly, Coral stated that the physical layout of the room was, “very challenging, this setup,” deterred the dogs from wandering freely and limited them to lying in the corner. In the following interview excerpt, Coral explained that the physical layout of the room created visual obstacles that restricted her line of vision and made it difficult for her to see the dogs:

So obviously the dog can't be there, and that's problematic because it would have been much nicer if the dog could've just wandered around like that. That was actually quite desirable I think. Having a dog in a corner that you can't see seems kind of pointless, really.

Brad, Borat, Coral, Danni and Mary described how they and others were concerned about physical aspects associated with dogs in the classroom. For example, Brad explained that he thought the dogs were, “going to pull something to pieces...I didn't want to see the joint fall in a heap.” Similarly, Borat, Coral, Danni and Mary expressed that they were concerned the dogs may damage equipment, unplug power

Table 16

Taxonomy of Environmental Domains and Characteristics

Domain	Element—facet—attribute
Physical domain	Layout and artifact use
Task domain	Structure
	Direction
	Professionalism
	Organisation
	Homogeny
	Time
	Teaching—learning style congruence and learning outcomes
	Teacher competence
	Self-efficacy
	Focus
	Emotion
	Confidence
	Interpersonal Skills
	Rapport building
	Dealing with conflict
	Behaviour management
	Communication
	Trusts

Domain	Element—facet—attribute
	Professional Practice
	Praxis
	Facilitating individual learning
	Presentation skills
	Technical knowledge
	Experience
Cognitive domain	Cognitive load
	Distraction
Affective domain	Emotional climate
	Annoyance
	Anxiety
	Disappointment
	Frustration
	Sufferance
	Unhappiness
	Positive characteristics
	Motivation
	Empathy
Social domain	Human agency
	Dominant voice
	Fear of retribution
	Prejudice

Domain	Element—facet—attribute
	Acquiescence
	Roles and hierarchy
	Normative behaviour
	Socialisation
	Forming
	Storming
	Mourning
	Movement
	Interaction

cords and that they posed an electrical safety risk. For example, Borat explained he thought that, “some people were cautious about, you know, their computers being unplugged.” However, in the following interview excerpt, Borat explained that he did not see this as a serious concern because he believed the dogs had natural abilities to untangle themselves. As Borat explained:

The dog has, you know, they are nature species. They get tangled all the time when they running in the woods or stuff, you know. They know how to untangle themselves, and I think personally I didn’t feel that it’s something to take care of. But I think yes, some people were more cautious of the dog being, you know, in the middle where the cables are. But I wasn’t at all, no.

These results appear to suggest that for some people, their interaction with the dogs was characterised by the layout of the room that created a physical barrier between them and the dogs, restricted the dogs’ freedom of movement, created visual obstacles

that limited visual contact, and for some, roused concerns about safety and protection of equipment.

Dog Interaction in the Cognitive Domain

All people who participated in event and post-course interviews, except Leigh, described facets that for them characterised their interactions with the dogs in the cognitive domain. These facets were attentiveness, distraction, and blindness.

Attentiveness

Five students, Andy, Borat, Coral, Mark and Wynnie, along with the teacher described attributes that for them characterised the attentive facet of their interactions with the dogs. These attributes were: arousal, that is, stimulation through interest and curiosity, breaking monotony and “waking up”; and refresh, that is, providing a refreshing mental break that helped students refocus. For example, Andy described how the dogs created arousal that, “broke the monotony. Runs around, fucks a few things up, wiring and that, ballses all the teachers up.” In comparison, Borat and Wynnie stated that the dogs woke them up and created arousal. For example, Wynnie explained that, “I was half asleep, the dog barked, it woke me up and I thought, ‘Oh Jesus, I was asleep, I better go and have a coffee.’” Wynnie’s comments were echoed by Borat, who explained that the dog created arousal through surprise:

It woke me up. It takes you out of your comfort zone because you get scared when something like that happens...surprised, surprised, that’s the word. Yes, so you kind of go, “Wow!” [Laughs] ... you go straight back to your, what you’ve been doing.

Mark described how the dogs were refreshing and, “alleviated the concentration levels for a while, and it was almost like refreshing, you know, just restart again.”

Mark’s comments were echoed by Andy, who explained that Adonis provided a short

mental release from concentration. He referred to the effect as, “breaking the ice,” a phrase that in other contexts is often used to refer to the process of initiating social interaction. Andy’s and Marks’ comments resonate with those of Sam, who described how the dogs provided short bursts of relief that she called, “brain breaks.” Sam explained that patting the dogs, “provides that relief...it provides that little, that short distraction which then allows you to regroup and then get back into the focus.” She also explained that she believed people’s attention spans were extended over a longer period through frequent, short interactions with the dogs. Sam stated that, “I think the main thing was those little distractions, that was the main thing...[Compared to] classes that I’ve had before, their attention span seemed to be longer.”

Coral and Andy used similes to describe attributes that characterised the attentive facet of their interactions with the dogs. Coral suggested that the dogs were, “like having one of those desk toys and things that you get at conferences where you can muck around with something, you know, looking at the dog doing that, and listening to other things coming.” This may suggest that for Coral the dogs acted as points of reflection or focus to aid concentration. Similarly, Andy described how the dogs were, “like an aide...towards the course,” that provided a focus for attention. In the same way, Sam implied a simile that likened patting the dog to having a cigarette, and said that, “Normally I’d go out and have a cigarette, but [laughs]. [If] I can’t have a cigarette, I’ll pat a dog, yes.”

These results suggest that for some people, their interaction with the dogs in the cognitive domain was characterised by short, frequent breaks that stimulated arousal and refresh that aided focus. For the teacher this appeared to extend students’ concentration spans over longer periods than expected.

Distraction

Nine students, Andy, Brad, Coral, Dan, Danni, Leigh, Mary, Morgan and Sharon, along with the teacher described attributes that for them characterised the distraction facet of their interactions with the dogs. Participants explained that they believed the dogs may have been a distraction for others by barking, by people looking at what they were doing, and by people attending to them such as keeping them from wandering under the tables and becoming entangled in cords. For example, Brad described how the dogs, “might have distracted other people at times, but you know, ‘Oh, there’s a dog there.’” Similarly, Danni said, “I think he’s [the dog] a bit of a distraction more than anything.” Coral also explained that she found the dogs distracting, “in order to keep the dog out [from under the tables.] So that was a distraction which probably wasn’t welcomed.” However, Leigh explained that the dogs, “unsettled more than distracted...or again being something that was unfamiliar.” Morgan explained that the dogs were unsettling because people were unsure of what was going to happen. Conversely, several students stated that the dogs were not distracting. For example, Dan explained that, “it certainly wasn’t a distraction at all at any stage, even when they had that barking, that was over in a minute for me. That wasn’t a problem.”

Dan explained that the distraction from the dogs was short-lived, did not have a significant impact and, “wasn’t really a distraction...It was over within ten or fifteen seconds.” On the other hand, Sharon explained that the teacher became annoyed when, “Adonis went under the desk and distracted Alma and she got a bit annoyed about it.” However Sam explained that the sociability of Adonis balanced out the negative aspects of distraction and that, “if he was like that all the time...people would probably find him more of a bad distraction...but because he’s sociable as well that counteracts.”

Six students and the teacher described distraction from the dogs in positive terms. For example, Sharon explained that, “when it got a bit boring it was a good distraction to see what they were doing...in fact it was more of a positive distraction.” Sharon’s comments were echoed by Andy, Danni and Morgan who described how the distraction from the dogs, by drawing attention to them, helped people maintain focus in the room rather than being distracted and looking out the window. For example, Andy explained that:

He [Adonis] took all the attention away from everything...the attention was on him. You didn’t see anybody sitting here all day looking out the window and all that did you? But someone was sitting there doodling with a pen in their mouth...they were watching what the dog was doing.

Similarly, Danni and Morgan described how the distraction from the dogs “brought him [Andy] back into it,” by drawing attention to them, and helped re-engage people who were distracted by other factors. For example, Morgan explained that, “even if they were elsewhere on the computer, it still distracted them again from what they were doing on the computer.”

Andy, Mary and Sam also described how the distraction from the dogs provided a short relief and refreshing break from concentration that allowed people to refocus and acted in a similar way to games used by trainers to stimulate their students. For example, Sam explained that:

You have that little interlude and then you’re back on task, and you can focus a lot easier...it’s like a distraction... but in a good way...[it] relaxes you, you’ve got more energy to get back into it...like games that trainers play to give them that distraction to bring them back on task.

Similarly, Leigh, Mary, Morgan, Sam and Sharon described distraction from the dogs as a, “nice distraction, a break from what you’re doing is a good break,” as a, “pleasant distraction when it became uncomfortable,” and as a, “nice distraction when people had nothing to do,” that provided people with, “something to look at, so the dog was entertainment.”

These results suggest that for some students, the volume of course content required focus and concentration. The dogs may have been seen as a distraction by some students, yet this distraction was seen as short-lived. It was seen as unsettling because it was unfamiliar. Yet for others the dogs were not a source of distraction. Half of the participants made the distinction between negative and positive distraction. They described how the distraction from the dogs was positive because it helped keep their focus in the room, helped re-engage people who were already distracted by drawing attention to the dogs, and provided a short relief and refreshing break from concentration that allowed people to refocus. For other students, distraction from the dogs was seen as nice, pleasant and comforting, and provided people with entertainment and something to look at when they had nothing to do.

Blindness

Seven students, Brad, Borat, Coral, Dan, Mary, Morgan and Wynnie, described attributes that for them characterised the blindness facet of their interactions with the dogs. For example, Brad and Morgan explained that their orientation towards dogs meant that they ignored them and did not pay attention to them. Morgan explained that, “I ignore dogs...I generally don’t pay attention to them. I concentrate on other things rather than them. However, Andy, Brad, Borat, Coral, Dan and Wynnie described how they quickly became familiar with having dogs in the classroom and were familiar with dogs in other contexts, and so forgot the dogs were there. For example, Dan explained

that, “sometimes I don’t think people knew they were there... Certainly interesting from the first day, but after the second, third, fourth day on, they were there, that was fine, they were part of the process.”

Borat, Coral, Mary, Morgan and Wynnie described how their focus on the course content was superordinate to their awareness of the dogs. For example, Coral explained that, “I’m used to dogs barking. Truly you’ve really got to stay pretty focused on the delivery. So the dogs haven’t really impacted that much I don’t think. You’ve just got to stay focused on what you’re doing.” The superordination of learning was echoed by Morgan who stated that she withdrew into a, “zone of learning something, that’s pretty much where I stay. I block out everything else.” Similarly Wynnie described how during the first week people were, “all keen, you know what I mean? Real keen, and we’re kind of not really observing the dog.”

These results may suggest that for some people, their interaction with the dogs within the cognitive domain was characterised by attributes of blindness that included being accustomed to dogs in the environment, and their subordination to learning.

Dog Interaction in the Affective Domain

All participants, except Brad and Mark, described facets that characterised their interactions with the dogs in the affective domain. These facets were emotion, emotional climate, motivation and empathy.

Emotion

All people who participated in event and post-course interviews, except Brad, described attributes that for them characterised the emotional facet of their interactions with the dogs. These attributes were amusement, anxiety, arousal, calm and enjoyment.

Amusement. Six students, Andy, Borat, Coral, Leigh, Morgan and Wynnie, as well as the teacher, described amusement by saying that the dogs were fun, created fun

for people, were entertaining and funny. For example, Borat recalled when the stray dogs entered the room, and said that, “people generally just had a fun, like, you know, ‘Hey, we’ve got more dogs than one, you know?’” The sense of fun created by the dogs was echoed by Coral, who said she thought it was, “a bit of fun, that these other dogs were like coming here and there was a dog here, it was like, ‘Oh, this is now the place where the dogs come.’ I thought was actually quite funny.” Sam described Adonis as, “the most fun,” which was echoed by Leigh. Morgan described amusement by saying that the dogs were entertaining and funny, “particularly for Danni, maybe she needed something to look at, so the dog was entertainment for her.” Similarly, in the following interview excerpt, Wynnie described amusement by saying that the situations created by the dogs were funny:

He was just running around sniffing crutches, and fair dinkum I was sitting there and I’m going, “Don’t laugh, don’t laugh.” And Sam’s looking at me, and I’m looking at her, and I’m trying not to laugh and I just started to laugh, and it was just funny.

Anxiety. Seven students, Borat, Leigh, Mark, Mary, Morgan, Sharon and Wynnie, described anxiety by saying that people were afraid, unnerved, upset, worried, shocked or scared when the dogs barked suddenly, which also created uncertainty. For example, Borat explained that, “it takes you out of your comfort zone because you get scared when something like that happens, you know like shock.” Though Borat said that there were, “people who were a little afraid,” Sharon explained that, “it wasn’t a fear, or is the dog going suddenly bite, or is it going to create a dangerous situation.” However Sharon balanced this by saying she was, “a bit of a nervy type when it comes to sudden things happening.” These comments were echoed by Leigh, Mark and Mary who said that the dogs, “may have upset people,” and that some people were a, “little

irked,” and a, “little bit worried,” when the dogs barked suddenly. Leigh explained that when the dogs barked suddenly, it created uncertainty that, “might have unnerved a few people because it was loud and it was aggressive, and it’s something that you’re not used to in a classroom situation... it’s just unusual.” The uncertainty created by the dogs’ behaviour was echoed by Morgan who said that she was, “unsure of what was happening, unsure of what was going to happen.” Wynn timer also described anxiety by explaining that she thought Adonis was attacking Reggie and said, “I had a little, little bit of a panic, a bit of flutter... I probably was a bit shocked... and then, ‘Oh, no, consequences for you, and consequences for the training people.’”

Arousal. Eight students, Borat, Coral, Dan, Danni, Lei, Morgan, Sharon and Wynn timer, as well as the teacher described arousal as the surprise and excitement created by the dogs. For example, Borat explained that he was, “surprised, surprised, that’s the word. Yes, so you kind of go, ‘Wow! We got a dog here.’” Borat’s comments resonated with Leigh who said, “a few people sort of jumped, like you could see they got a fright.” Similarly, Morgan said, “I did jump cause it was dead quiet and then it started barking.” Coral and Sam also described the surprise created when the dogs barked suddenly. For example, Coral stated that, “I think one of the dogs barked behind me at one stage and I got a bit of a surprise, it’s just that sudden loud noise.” Similarly Wynn timer explained that when the dogs barked suddenly, people woke up and that she, “could see them jump with a bit of a fright.”

Dan and Sharon explained that the unexpected behaviour of the dogs created, “excitement for the minute,” because it was, “more interest and it was excitement.” Wynn timer also described the excitement created by the unexpected behaviour of the dogs when she said, “it was good cause I was going to sleep and I heard them... excitement, excitement.” Danni described arousal by recounting that, “every time he [Adonis] came

near her [Sharon], she lit up and would respond to him.” Similarly, Morgan said that, “a lot of people got excited when they [the dogs] arrived. Like particularly after lunch it was sort of like the dogs brightened up their afternoon.”

Calm. Six students, Coral, Dan, Danni, Leigh, Mary and Morgan, as well as the teacher, described calm by saying that the dogs were relaxing, calming and comforting. For example, Coral explained that watching the dogs’ behaviour was relaxing because she was, “able to observe, sort of unconscious kind of doggy behaviour is perhaps a relaxing thing.” Similarly, Sam explained that the dogs, “really made me calm down...settles my nerves, relaxes me.” Mary, Morgan and Sam also described calm as feeling comfortable and at ease. For example, Mary explained that, “I think, for some people it’s a very positive thing, it makes them feel more comfortable and at ease.”

Enjoyment. Eight students, Andy, Borat, Coral, Dan, Danni, Leigh, Mary and Morgan, as well as the teacher, described enjoyment by saying that people felt happy and enjoyed having the dogs in the classroom, and that people experienced generalised pleasure and happiness. For example, Danni said that having the dogs in the classroom, “makes you feel happy,” which resonated with Borat’s comment that, “I think generally, yes. Because you had people who were cheery and happy about it.” Danni described her experience as, “very pleasant,” which echoed Coral’s comment that, “having the dog wandering around was nice.” Similarly, Leigh said that, “I like having them around...I think generally speaking, having the dogs there was a good thing that people enjoyed having them there, enjoyed their presence, enjoyed being able to pat them.” However Morgan, who was not positively oriented towards dogs, described enjoyment in neutral terms and said that, “doesn’t phase me, doesn’t, what’s the word, I’m not pleased by it.”

Summary. Reported in Table 17 is the frequency distribution of emotional attributes and comments made by participants. The most frequently reported emotional attributes by the largest number of participants were: arousal, that is, the surprise and excitement created by the dogs that for some people woke them up; and enjoyment, that is, feelings of generalised pleasure, enjoyment and happiness. To a lesser extent, emotional attributes of amusement, that is, entertainment and fun, along with calm through relaxation and comfort were also emotional attributes that characterised people's interaction with dogs in the affective domain.

Nine participants reported that their interaction with the dogs was characterised by at least three attributes, and six participants, Coral, Dan, Danni, Leigh, Morgan and Sam reported arousal, calm and enjoyment as common attributes. Seven students said they or others experienced anxiety. However, all of these people, except Mark, also said they or others experienced positive emotions of amusement, arousal, calm or enjoyment. Negative emotions of anxiety were reported only in relation to the barking event. However, those students who reported feeling these negative emotions, said that the experience was short lived and was followed by positive emotions. Wynnie described anxiety indirectly as the fear of Reggie being attacked and the fear of negative consequences for others should that have occurred.

Brad and Mark were the only students who did not describe attributes that for them characterised the emotional facet of their interaction with the dogs. This could be due to Brad's orientation towards and enculturation of dogs, and his perceptual blindness to them in the classroom. Mark did not describe any positive or negative emotional characteristics.

These results may suggest that people's interaction with dogs in the emotional domain, may be characterised primarily by arousal, calm and enjoyment. These results

Table 17

Frequency Distribution of Emotional Attributes and Comments

Participant	Amusement	Anxiety	Arousal	Calm	Enjoyment	Frequency	Distribution
Andy	1				1	2	2
Borat	2	2	2		1	7	4
Coral	1		1	1	3	6	4
Dan			1	1	2	4	3
Danni			1	1	1	3	3
Leigh	2	5	2	1	3	13	5
Mark		1				1	1
Mary		1		2	1	4	3
Morgan	2	2	6	3	1	14	5
Sam	2		1	3	3	9	4
Sharon		2	3			5	2
Wynn timer	14	4	3			21	3
Frequency	24	17	20	12	16	89	
Distribution	7	7	9	7	9		

may further suggest that for some people their interaction with dogs may be characterised by anxiety. However for those people it may also be characterised by amusement, arousal, calm or enjoyment.

Emotional Climate

Nine of the 13 participants interviewed, Andy, Borat, Coral, Dan, Danni, Leigh, Mary, Morgan and Sharon, described how their interaction with the dogs in the affective domain was characterised by a positive emotional climate that Andy said, “just felt like a warmer environment.” For example, Dan described the emotional climate as, “more peaceful.” Similarly, Leigh explained, the dogs, “just break up the vibe a little bit,” and created a, “less serious atmosphere...people by the end of the course dressed quite comfortably...They’re more informal and you’re quite able to talk more freely and that sort of thing as well.”

Borat explained that the dogs created a feeling of freedom where, “you are able to do things and not, I mean you know when I was back in Europe and I took Rocky with us on our holidays, it would be thrilling to be able to take my dog to work.” In the same way, Coral described the normalising effect of the dogs on the emotional climate in the classroom like, “the windows got open and you could be part of the outside world...it brings normality into the training room.”

For Morgan and Mary, the dogs were, “a very positive thing, it makes them [other people] feel more comfortable and at ease.” Similarly for Sharon, the dogs provided a non-controversial focus for conversation and for Dan, they helped relieve the stress associated with getting to know people. In the same way, Danni explained that for her and others, the dogs helped balance an emotional climate that was characterised by tension because, “were a bit more tense...and that dog seemed to calm

us down.” Morgan also explained that the teacher could contribute to fostering a relaxed and less formal emotional climate by interacting with the dogs:

It would have been more relaxed because by her walking around the room and patting the dog shows that she was relaxed, and relaxed enough to do that. So therefore we could have been relaxed enough to go and get a drink of water... It wouldn't have been such a formal thing where the teacher's at the front and all the students sit at the table and don't move. So less formal by her showing us that it's a relaxed environment, it's not such a tense environment.

These results may suggest that for many students, their interaction with the dogs in the affective domain was characterised by an emotional climate that was seen as warm, calm, relaxing, informal, and normalising with the outside world.

Motivation

One student, Morgan, described the opportunity for the teacher to contribute to students' motivation by interacting with the dogs that may have created interest and stimulation:

It would have given us a chance to digest whatever she had just read out by going over to the dog and then coming back to something else to digest. But because it was all just read, read, read...not a lot was taken in. It would have made us move. It would have been stimulating because...it was very rare for me to actually turn around to the table that was there.

These results may suggest that for at least one person, their interaction with dogs in the affective domain was characterised by motivation to learn, created by the teacher interacting with the dogs to create interest and stimulation.

Empathy

Four participants, Danni, Mark, Sam and Wynnie, described how their interaction with dogs in the affective domain was characterised by empathy and concern for the safety and well-being of the dogs. For example, Danni said that she, “didn’t have a problem with him [Adonis] going under there long as he didn’t hurt himself.” This was echoed by Wynnie who said, “and everyone’s going, ‘Oh, it’s not safe for the dog in there. It’s not safe for the dog.’” Wynnie and Danni also described how they were concerned for the health of the dogs, which may have been compromised by the introduction of strays. For example, Danni explained that, “they shouldn’t have been allowed to interact with a healthy dog like Adonis...that would be devastating if those other dogs had brought some sort of disease upon Adonis. Adonis was put in an at-risk situation.” Similarly, Sam expressed empathy for the dogs by saying, “How dare they come in a steal his thunder? [He is] our dog, yes, that’s our dog, what are those strays doing here?” In contrast, Mark expressed empathy because, “the dog was upset,” when the strays walked past and caused Adonis to bark. Wynnie expressed empathy for the dogs when they barked by saying that it was, “not his fault...leave him alone,”

These results may suggest that for some people, their interaction with dogs in the affective domain was characterised by empathy for the health and safety of the dogs, and for their emotional and moral well-being.

Dog Interaction in the Social Domain

All students who participated in event and post-course interviews described facets that characterised their interaction with the dogs in the social domain. These facets were appeal, human agency, enculturation, social axioms, and socialisation.

Appeal

All people who participated in event and post-course interviews, except Mark, described attributes of appeal that for them characterised their interaction with dogs in the social domain. These attributes were bond, energy, physical, handler, sociability, initiator, behaviour, personality and eye contact.

Bond. Reported at Table 18 are the comments and contrasting characteristics¹¹ that people used to describe bond as an attribute of appeal. These comments suggest that this attribute may be described as being able to relate to and communicate with the dogs, feeling close and drawn in by the dogs, feeling a connection with the dogs, and the dogs appearing to show empathy towards an individual.

Energy. Reported at Table 19 are the comments and contrasting characteristics that people used to describe energy as an attribute of appeal. These comments suggest that this attribute may be described as wandering and racing around, having energy and being energetic, interacting with people, and as the dog having fun by himself. This description contrasts with appearing to be well-trained, old, passive, placid, inactive, quiet and unnoticed.

Physical. Reported at Table 20 are the comments that people used to describe physical attributes as an attribute of appeal. These comments suggest that this attribute may be described as appearing clean, fluffy, beautiful, cute, soft with attractive facial features, hair and ears, and as breathing heavily and smiling.

¹¹ Contrasting characteristics were not used to describe the dogs as unappealing, but rather were used to distinguish those characteristics that people found appealing about the dogs.

Table 18

Comments Used to Describe Bond

Participant	Comment
Appealing characteristics	
Andy	I can sort of relate with dogs sort of, communicate with them.
Danni	Probably liked the fact that Buddy was there, because I felt closer to him than the other dogs.
Danni	Maybe that's personal, one-on-one.
Sam	The concern that she showed me that day we just sort of, yes, we had a thing going.
Sam	We formed this relationship.
Sam	The day that she was concerned about me, we formed a relationship.
Sharon	[I felt a connection] with the dogs.
Wynn timer	I like the dogs and I go and play with them but, it's like your friend, you know, you pick your friends, and it's like I relate to our dog.
Contrasting characteristics	
Wynn timer	I couldn't sit there and talk to him.
Wynn timer	I don't know Buddy enough.
Wynn timer	Didn't really connect.
Wynn timer	No real bonding or anything because you don't get enough time to bond with them either.

Table 19

Comments Used to Describe Energy

Participant	Comment
Appealing characteristics	
Borat	I just liked him wandering around.
Brad	The Labrador appeared to poke about a bit.
Coral	It would have been much nicer if the dog could've just wandered around like that.
Coral	But actually having the dog wandering around was nice.
Coral	It's quite interesting just observing dogs.
Coral	I guess maybe she could kind of lie around and people would look at her.
Dan	Adonis was down sniffing underneath, eating sausage rolls off the floor, he was having a good time.
Leigh	Adonis was more just, you know, rowdy Adonis.
Leigh	Well he wasn't as disciplined really in terms of sort of going where he wasn't supposed to go and that type of thing.
Mary	Adonis because he wandered around a bit more.
Sam	Probably the difference between Adonis being a younger dog and Lady being an older dog, he's a lot more energetic.
Sharon	Lady, she's probably more the calming.
Sharon	He was a relaxing chappy.
Wynnne	Adonis was more entertaining.

Contrasting characteristics

Participant	Comment
Andy	What did she do? She went and sat in the corner.
Andy	That little dog, little fluffy fella, he didn't do a real lot either.
Borat	These other dogs were well trained dogs.
Borat	Lady seems, just sitting there with her owner... I really didn't get much of that dog.
Brad	The other blokes just laid there.
Brad	The other blokes they just laid there.
Coral	Having a dog in a corner that you can't see, seems kind of pointless.
Danni	Cause Lady doesn't interact.
Leigh	Just sort of tended to sleep.
Leigh	You almost didn't know that Lady was there.
Leigh	Lady was a bit more kind of introverted, I think.
Mary	Lady kept to herself a bit.
Mary	If anyone was up the front of the room they wouldn't have noticed Lady.
Mary	Lady was more reserved.
Morgan	This one sits a lot more. Not as active.
Sam	Lady's more reserved.
Wynn timer	Lady was too quiet.
Wynn timer	Lady was very quiet. You never knew Lady was there.
Wynn timer	But the other ones were very well behaved and very placid kind of dogs.
Wynn timer	And you had the quiet dog, Lady, that didn't go anywhere in the afternoon.

Table 20

Comments Used to Describe Physical

Participant	Comment
Appealing characteristics	
Andy	The bigger one I really liked that dog, it was really nice.
Borat	I like the facial impression of that dog, because it had you know, little hair here, ears you know, and because they breathe so heavily, they look like they're smiling all the time.
Borat	I think that smile, you know and the hairdo.
Leigh	Buddy's beautiful. Buddy's gorgeous.
Leigh	Nice clean fluffy dog.
Leigh	I thought Buddy was beautiful.
Leigh	They're just, you know, beautiful dogs.
Mary	He was cute.
Wynn timer	Cause he's just cute, and fluffy and soft.
Wynn timer	Like I can go and touch Buddy and he's so cute.
Wynn timer	He was really cute.

Handler. Reported at Table 21 are the comments and contrasting characteristics that people used to describe the handler as an attribute of appeal. These comments suggest that this attribute may be described as appearing approachable, social and easy to get along with, outgoing, initiating conversation, and encouraging interaction with the dogs. This description contrasts with appearing reserved, and passive.

Table 21

Comments Used to Describe Handler

Participant	Comment
Appealing characteristics	
Leigh	The lady with Buddy...she's lovely and she was wanting to talk to everybody and she wanted everyone to see Buddy and for Buddy to talk to everybody.
Leigh	Alma being as outgoing as she was, you were more inclined to go up and talk to Buddy as well.
Contrasting characteristics	
Danni	It's not the carer of the dog either.
Danni	It didn't matter what the carer was like...because every one of them were happy for their animal to be interactive.
Leigh	Whereas Lady's owner was a bit more reserved, and read a book, and Lady didn't really wander around too much.

Sociability. Reported at Table 22 are the comments and contrasting characteristics that people used to describe sociability as an attribute of appeal. These comments suggest that this attribute may be described as appearing approachable, friendly, sociable, trustworthy, fun and entertaining, and fostering a feeling that, "you'd like to give them a pat." This description contrasts with appearing to be concerned with own self, not displaying interest, and not approaching people.

Table 22

Comments Used to Describe Sociability

Participant	Comments
Appealing characteristics	
Borat	She is approachable, trustworthy.
Dan	Like you could see Buddy was really a people pleasing type of dog.
Danni	He just was an approachable animal, friendly.
Danni	A nice dog, and he's approachable.
Leigh	Buddy was just friendly.
Leigh	They're just friendly creatures.
Leigh	Wanted to be patted, and you just feel like you'd like to give them a pat.
Mary	He's quick to socialise.
Sam	He's more sociable.
Sam	He's a sociable dog, a much more sociable dog.
Sam	But because he's sociable as well that counteracts.
Wynn timer	Buddy's a very well dog like, I think he really did get along with everyone.
Contrasting characteristics	
Sam	But he was also not sociable.

Initiator. Reported at Table 23 are the comments and contrasting characteristics that people used to describe initiator as an attribute of appeal. These comments suggest that this attribute may be described as appearing to seek people out, initiating interaction, approach rather than waiting to be approached, coming up to people, looking for and wanting to be patted, looking for recognition, and wanting to play. This description contrasts with appearing not to be inquisitive, curious, interactive, a responder rather than initiator, and as not approaching people.

Behaviour. Reported at Table 24 are the comments and contrasting characteristics that people used to describe behaviour as an attribute of appeal. These comments suggest that this attribute may be described as appearing young, cute and irresistible by displaying puppy-like behaviour, being mischievous and naughty, and appearing authentic.

Personality. Reported in Table 25 are the comments and contrasting characteristics that people used to describe personality as an attribute of appeal. These comments suggest that this attribute may be described as appearing to have a good attitude and being “cool,” having a nice personality, being lovable, and having brains and character. This description contrasts with appearing to lack personality, and as being a, “spoilt brat,” or “sook.”

Eye contact. Reported at Table 26 are the comments and contrasting characteristics that people used to describe eye contact as an attribute of appeal. These comments suggest that this attribute may be described as looking people directly in the eye and maintaining eye contact, and giving a person a particular look. This description contrasts with appearing not to make eye contact.

Table 23

Comments Used to Describe Initiator

Participant	Comment
Appealing characteristics	
Andy	And he kept coming back.
Borat	I just liked when he came in and you know, put his nose into my hand or something.
Borat	I didn't have to approach, he would approach me... that was easier for me.
Borat	Adonis, you know he just comes in, shovels his nose into your arms, you know, or into your palm.
Dan	Buddy would look people out wouldn't he? He'd go looking.
Dan	Although Adonis did it [sought people out] a little bit.
Dan	Buddy went looking for people too.
Dan	Adonis didn't care, he'd go to anyone.
Leigh	[The dogs] that come up and want to play.
Leigh	Buddy would come up and say, "G'day," and you'd pat him.
Mary	They wanted to pat him if he came near them.
Sharon	Buddy would come up to you.
Sharon	Buddy would actually come up to you as a dog.
Sharon	She came looking for you a couple of times.
Sharon	Oh he, sort of commands a little bit of attention, didn't he? He was trippy.
Wynn timer	Adonis, always, he come and sniffed everyone.

Participant	Comment
Contrasting characteristics	
Coral	I guess she's not such an inquisitive or curious or interactive kind of dog. If you interact with her, she's happy with that.
Leigh	She didn't come around as much.
Morgan	Doesn't walk in and around the people and stuff.
Sam	Lady is not an initiator, Lady will, Lady more responds to somebody else.
Sam	Lady responds to people.
Sharon	Lady didn't come over if she didn't want to come over to you.
Sharon	I found I wanted her to come to me and she wouldn't.

Summary. Reported at Table 27 is the distribution of comments made by participants to describe characteristics of appeal reported by participants, including contrasting characteristics and the dog for which each stated a preference. Buddy and Adonis were the dogs preferred by most students. However Lady was the dog most preferred by the teacher, Sam. During the interview, Mark did not describe any characteristics that he found appealing about the dogs and along with Morgan, did not state a preference for one particular dog. The attributes of appeal most frequently reported by participants were energy and initiation. Energy, that is, the extent to which the dog wandered around the room and was active, was reported on 34 occasions by 12 participants. Initiation, that is, the extent to which the dog approached people and initiated interaction with them, was reported on 23 occasions by ten participants. Other frequently occurring attributes of appeal were personality and sociability. Personality, that is, appearing to have a good attitude and being “cool,” having a nice personality,

Table 24

Comments Used to Describe Behaviour

Participant	Comment
Appealing characteristics	
Borat	I really liked that dog because it was, it acted as a puppy.
Borat	Being more, I mean he barked and everything, so he was a real dog.
Dan	The temperament of those dogs, it worked fine.
Dan	They were extremely well behaved.
Sam	Mischievous and those sort things.
Sam	It balances out the naughty bits.
Sam	When you get a naughty child, but they're just so cute and you can't resist them.
Sam	I mean he's a much younger dog, and of course he does things that puppies do, that, you know, that are just cute.
Contrasting characteristics	
Brad	I don't allow a dog to lick me... [I] can think of nothing worse.
Danni	I thought maybe he was a little immature, but then I learned today he's actually a four year old animal.

Table 25

Comments Used to Describe Personality

Participant	Comment
Appealing characteristics	
Andy	Just his attitude, mate.
Andy	Adonis has character, and mate he's got a brain that dog, eh.
Andy	Fair dinkum he's got a brain in his head that old dog.
Borat	The last dog...was so happy dog.
Danni	Adonis is fun loving.
Danni	Something can come out of that one particular personality of an animal.
Danni	It comes down to the dog itself.
Danni	I think it's the personality of the dog that comes into it.
Leigh	[The dogs] have nice personalities.
Sam	I enjoyed seeing the dogs, like the same dog and getting to know each of the different personalities of the dogs.
Sharon	Buddy was a very relaxed, nice dog.
Sharon	The dogs had different personalities.
Sharon	It wasn't as if, if you were an introvert, you wouldn't find a dog that was as quiet as you wanted to be, or if you wanted to be a really, like Andy was, you know with Buddy, out there.
Sharon	So it wasn't like you were just stuck with one dog with one personality type.

Contrasting characteristics

Participant	Comment
Coral	Lady was a little bit that way [aloof].
Dan	I thought Lady was a little bit aloof.
Danni	The other dogs were a bit more concerned about themselves.
Leigh	Lady just didn't have as much personality.
Sam	He was a sook.
Sam	I don't like sooky kids, I don't like sooky animals.
Sam	He had that pat me look, but he was a spoilt brat.
Sharon	We've always said that Lady's aloof.
Wynn timer	Whereas Lady's very prim and proper true.

being lovable, and having brains and character, was reported on 22 occasions by nine participants. Sociability, that is, is the extent to which people found the dog to be approachable, entertaining and fun, was reported on 13 occasions by seven participants.

An interesting characteristic described by Andy, Danni and Sam was the extent to which the dogs made eye contact with them that may suggest for these people, eye contact contributes to developing a bond with the dogs. The behavioural and physical attributes described by Borat, Dan, Leigh, Mary Sam and Wynn timer, suggest that for them the neotonistic qualities such as puppy-like behaviour and appearance are important attributes of appeal.

These results may suggest that for most people, their interaction with dogs in the social domain was characterised by two main attributes of appeal, that is, the energy and activity displayed by the dogs, and the extent to which dogs approached people and

Table 26

Comments Used to Describe Eye Contact

Participant	Comment
Appealing characteristics	
Andy	I was looking at him eh, and I've only got to make certain movements, especially with your eyes.
Danni	Looked at you with his eyes...drew you into him as well.
Danni	That last dog, you know, he'd give you eye contact.
Danni	Like when I was eating there, at one stage I turned around to get away from his gaze, you know.
Contrasting characteristics	
Danni	The other dogs, didn't give you eye contact, not to me anyway.

initiated interaction. These results may further suggest that for some people, their interaction with dogs in the social domain was also characterised by the perceived personality of the dogs and their sociability. For a smaller number of people, these results may also suggest that the ability to develop a bond with the dogs, maintaining eye contact with the dog, and the neotonic qualities of the dogs' physical appearance and behaviour were also important attributes of appeal.

Human Agency

All people who participated in event and post-course interviews described attributes that for them characterised the facet of human agency, that is, the capacity of people to exercise control over how they interacted with the dogs. These attributes were

Table 27

Frequency Distribution of Attributes of Appeal

Participant	Preferred dog	Bond	Energy	Physical	Handler	Sociability	Initiator	Behaviour	Personality	Eye contact	Frequency	Distribution
Andy	Adonis	1	2	1			1		3	1	9	6
Borat	Buddy		3	2		1	3	2	1		12	6
Brad	Adonis		3					1			4	2
Coral	Adonis		5				1		1		7	3
Dan	Buddy		1			1	4	2	1		9	5
Danni	Buddy	2	1		2	2		1	4	4	16	7
Leigh	Buddy		5	4	3	3	3		2		20	6
Mary	Adonis		4	1		1	1				7	4
Morgan	None		1				1				2	2
Sam	Lady	3	2			4	2	4	4		19	6
Sharon	Buddy	1	2				6		5		14	4
Wynn timer	Buddy	5	5	3		1	1		1		16	6
Frequency		12	34	11	5	13	23	10	22	5	135	
Distribution		5	12	5	2	7	10	5	9	2		

desire, effort, opportunity, social hierarchy, pretence and conspicuousness, behaviour of others, normative behaviour and authority.

Desire. Five students: Andy, Borat, Danni, Mary and Sharon, described attributes that for them, characterised desire as wanting to interact with the dogs. For

example, Borat explained that he thought would be, “more interacting with the dog than I am really interacting with the dog, which is really surprising to me.” Danni described how others displayed little desire to interact with the dogs and were, “shutting him out...I feel that they don’t want to know the dog’s there, just ignore the dog. Not the situation they expect to see a dog in maybe.” Danni’s comments were echoed by Andy who explained that he saw people pushing the dogs away and said, “the dog would come near and they would, ‘Oh, get away from me,’ sort of thing, ‘Don’t touch me.’ They haven’t got the time to sit down, say hello, and give him a pat.”

Sharon explained that for her, desire was connected to, “personality types as to...whether you want that human or that dog interaction.” Similarly Mary described how the desire to interact with the dogs was dependent on people’s disposition and whether people were, “really keen on dogs.” Mary also likened the desire to interact with the dogs to walking up and patting a stranger’s dog in public that, “some people would do...when they’re walking along the street, they’ll go up and pat a stranger’s dog. I wouldn’t probably do it.”

Effort and opportunity. Five students, Borat, Coral, Mary, Sharon and Wynnie, described attributes that for them characterised the effort of getting out of their chairs to initiate interaction with the dogs, and the opportunities available to interact with them. For example, in the following interview excerpt, Mary compared the effort of getting out of her chair to interact with the dogs, to the effort of interacting with the dogs when walking past or when the interaction was initiated by the dogs:

I probably wouldn’t have gone and made an effort to pat the dog by getting up from my chair to. But if I was walking past, then I would pat the dog. Or the dog came to me, yes, then I’d pat it...I think quite a lot of people probably would do

the same, they're not going to go up to a dog that's not theirs, and just go and pat it.

Similarly, Wynnie said that if Buddy had gone over, people would have interacted with him more but, "getting up out of your chair, no I don't think they would have...Alma wouldn't notice them sitting there on the internet." Sharon said that the effort to interact with the dogs would, "require some interaction, and perhaps at that point, for whatever reason, they were engaged in solitaire." Similarly, Borat described the effort of having to, "walk around you, or around the dog owner, and that's another distraction, you know, it's another like barrier between me and the dog."

Borat described opportunity as the time available to interact with the dogs, which he compared with getting a drink that he saw as a, "quick thing, with a dog, you need more time. And sometimes, personally I don't want to engage dog if I'm...limited. I want to engage dog as long as I or the dog are happy to." Borat's description of opportunity was echoed by Coral who explained that, "there was not much time to look around and see what the dog's up to."

Social hierarchy. In the following interview excerpt, Sharon described the facet of social hierarchy by saying that for some people, the dogs may have been subordinate to students in the social structure of the classroom:

I often wonder too whether it's a microcosm of what a community would be in because it's where the people in the room put the dogs in the scheme of things as far as the people were concerned you know....the way they perceive themselves as to, as where they fit into the social hierarchy... maybe they felt that the dogs were a bit beneath them as well as the rest of us.

Pretence and conspicuousness. Four students, Borat, Danni, Leigh, Mary and Wynnie, along with the teacher, described attributes that for them, characterised

pretence and conspicuousness as students used computers to perform personal tasks so that they would appear to the teacher to be working on lesson related content. They compared this to the overt action of interacting with the dogs that would draw attention. For example, in the following interview excerpt, Borat explained that using the computer was a convenient and covert form of distraction that he compared to interacting with the dog:

You have that computer at your fingertips, so if something happens you always can jump into your answer sheet and do it at that time. When you are here with the dog, you have to walk back to your table, you know, you have to walk in front of that overhead projector, so you brought more attention to yourself.

The comparison between overt interaction with the dogs and the covert pretence with regard to the use of computers, was echoed by Danni who said, “I think people can interact with their computers and not feel caught out, or that they’re seen as being involved, but they’re not.” Similarly, Wynnie explained that students believed the teacher would not notice what they were doing when they used the computers as a distraction, and described it as, “the old school kid trick.” She reasoned that, “if we all got up and played with the dog, she [the teacher] would notice.”

Borat explained that overt visibility was a significant concern for him, that he was conscious of his height and foreign accent, and that, “visibility’s a big thing for me and like especially now like I’m tall person and I have accent. So that’s another two aspects that increases the visibility of myself, you know?” Borat’s concern about conspicuousness was echoed by Mary who felt that standing up, getting out of her chair, walking away from the table and going over to the dog, would make her look, “a little more obvious.” Similarly, Leigh said that using the computer was easier than interacting with the dogs because it “did not draw attention.”

Sam described her lack of awareness of what students were doing when using the computers and implied that it was acceptable because, “while they’re sitting there playing cards, or looking up the web sites, I can’t see what they’re doing, so they look as if they’re paying attention...but its okay cause the teacher doesn’t notice.” Sam explained that she felt the classroom environment aroused student’s childhood education experiences to which she attributed this form of pretence, and likened it to passing notes in class.

Behaviour of others. Leigh explained that the behaviour of Reggie who sat next to her, and whom she perceived as not being comfortable with the dogs, discouraged her interacting with them because she felt, “I shouldn’t have the dog near her. And when Reggie wasn’t there it was great. I wanted to pat the dogs and when they were near me I was going to pat the dogs.”

Normative behaviour. Eight students, Brad, Borat, Coral, Dan, Danni, Mark, Sharon and Wynnie along with the teacher, described attributes that for them, characterised normative behaviour as the establishment of unspoken social rules that made students feel that it was not acceptable for them to play with the dogs during the lesson periods. However it was acceptable for the dogs to bark and wander freely. Wynnie reasoned that even if the acceptability of interacting with the dogs was reinforced, “I don’t think it would change it, because...you didn’t really notice the dog was there.” Conversely, Sam felt that she could have reinforced the acceptability of interacting with the dogs to, “make it more obvious, and I’d probably say it several times, even every day. Reinforce that it’s fully acceptable to do that.” In the following interview excerpt, Sam also surmised that her own behaviour may have influenced what was seen as acceptable behaviour:

I wasn't playing with the dog when I was talking, when I was passing on information. I was doing it when they were doing a task, and I was going around checking. That's when I actually pat the dog on the way past, or play with the dog on the way past, while they were busy. So that could have also been a bit of yes, modeling behaviour.

Borat, Coral and Sharon said that they felt the breaks and, "slack off time," were the most appropriate moments to interact with the dogs. Borat stated that students, "didn't feel appropriate to do it in that work time." Sam described work time, was when, "it was acceptable for them to get up and go and make a coffee. It was acceptable for them to get up and go to the toilet. It was acceptable for them to get stuff off the printer because that's work."

Five students, Borat, Brad, Dan, Danni and Wynn timer, along with the teacher, described characteristics of normative behaviour as the extent to which it was acceptable for the dogs to bark and wander freely because it was expected, natural and spontaneous. For example, Sam explained that it was acceptable for Adonis to bark because, "he does things that puppies do... that are just cute. Barking at the other dogs and all that sort of thing, it's acceptable because he's a pup." She compared Adonis to Lady, and said that it would not have been acceptable for Lady to bark because, "people are scared of Shepherds." Sam's comments were echoed by Dan and Mark who, in addition, saw the barking as short lived. For example, Dan explained that, "the whole thing was over with within a minute. It didn't seem to last too long all...and it was sorted out fairly quickly...that was over in a minute for me, that wasn't a problem." For Brad however, barking was, "bad news; you don't have barking dogs. Where I come from, if a dog barks you got a problem."

Wynn timer described the behaviour of the dogs as acceptable because it was a natural, “part of having the dog here. We all agreed to have the dog here, and like animals are unpredictable... that would be the dogs’ natural behaviour is to go for another dog.”

Wynn timer’s comments were echoed by Borat who explained that the wandering and barking behaviour of the dogs was a natural characteristic and people should, “let the dog be the dog... why do you have dog if you think it will not bark? Why do you have cat if you think it no meow?... That’s one of the things they do. It’s natural.”

Authority. Wynn timer described authority by saying that students knew they were, “supposed to be doing something, and I guess maybe respect for Alma not to be disruptive. Like if we all got up and went and played with the dogs and then the whole classroom environment’s blown out isn’t it?” Similarly, Morgan described authority by saying that she did not feel comfortable getting up and interacting with the dogs because, “it wasn’t comfortable. Like I didn’t even feel comfortable to get up and get a drink of water.”

Summary. Reported in Table 28 is the frequency distribution of attributes reported by participants that characterised human agency. Of the seven attributes reported, normative behaviour, which was reported on 20 occasions by eight participants, and pretence and conspicuousness, which was reported on 13 occasions by six participants, were the most frequently reported attributes of human agency. Desire, which was reported on 8 occasions by five students, and effort and opportunity, which were reported on ten occasions by five students, were also frequently reported characteristics of human agency.

Table 28

Frequency Distribution of Human Agency Facets

Participant	Desire	Effort and opportunity	Social hierarchy	Pretence and conspicuousness	Behaviour of others	Normative behaviour	Authority	Frequency	Distribution
Andy	2							2	1
Brad						2		2	1
Borat	2	5		5		4		16	4
Coral		1				1		2	2
Dan						2		2	1
Danni	1			1				2	2
Leigh				1	1			2	2
Mark						1		1	1
Mary	2	2		1				5	3
Morgan							1	1	1
Sam				3		7		10	2
Sharon	1	1	1			1		4	4
Wynnie		1		2		2	1	6	4
Frequency	8	10	1	13	1	20	2	55	
Distribution	5	5	1	6	1	8	2		

This table shows a wide distribution of facets and attributes reported by participants, and no discernable patterns between them. This may indicate that for each person, human agency was defined by only a few attributes, which were different for each participant.

These results may suggest that for most people, human agency as a facet of dog interaction in the social domain was characterised predominantly by the establishment of unspoken rules concerning the acceptable behaviour of people and the dogs. These results may further suggest that for some people, human agency was also characterised by a desire to play and interact with the dogs, and the effort required as well as the opportunities available to do so.

Enculturation

Six of the 13 people who participated in event and post-course interviews, Andy, Borat, Brad, Dan, Sam and Wynnie, described attributes that for them characterised enculturation. Grusec and Hastrings (2007) describe enculturation as the acquisition of values and behaviours appropriate to a particular culture. The attributes described by participants were breed, regional, personal and technology.

Breed. All participants who described attributes that characterised enculturation, described values and beliefs about different breeds of dogs. For example, Andy said that he saw Labradors who performed roles as guide dogs for the blind and in visiting aged care facilities as caring and, “smart them buggers.” In contrast, German Shepherds were seen as aggressive through their protective capacity associated with their roles in security, prisons, as guard dogs, and in the armed services. For example, Sam explained that, “people are scared of Shepherds because they’re always in security, prisons, guard dogs, RAF [Royal Air Force] you know, police, air force all of that sort of stuff, they’re seen as a vicious dog.” Sam also described German Shepherds as, “an intelligent dog

that they use...in the forces,” which contrasted with Andy’s, Brad’s and Borat’s description of them as aggressive and dangerous. For example, Andy described them as having, “the killer in them,” which distinguished them from Labradors, who Sam described as, “sociable animals, they’re known to be gentle with kids.” Sam’s description of Labradors was echoed by Brad who said that, “from what I know about Labrador’s, that’s a Labrador, they’re friendly, they race around.” These differences were echoed by Dan who said, “Stereotype of an Alsatian hey, isn’t it, aggressive type dog whereas Adonis is a Labrador, which is a more relaxed type of dog.”

Sam said that people’s values and beliefs about German Shepherds were similar to those of Pit Bulls and may have factored in their interactions with Lady. She explained that, “if you had a Pit Bull in there as well, they probably wouldn’t interact with the Pit Bull either.” Similarly, in the following interview excerpt, Brad compared people’s values and beliefs about German Shepherds to Alsations, which he saw as a different breed who, because of their aggression, were banned in Western Australia 30 years ago¹²:

¹² The German Shepherd and Alsatian are the same breed. The German Shepherd breed was renamed the Alsatian Wolf Dog at the end of World War I as the inclusion of the word ‘German’ was thought to harm the breed’s popularity (Palika, 2008; Rice, 1999). The breed was renamed German Shepherd in 1977 (Gordeeva, 2009). In 1929 the importation of new breeding stock was banned in Western Australia, which was later lifted in 1976 (German Shepherd Dog Association of Western Australia, 2010),

I think they're more dangerous. That's that German Shepherd, isn't it? They're banned in Western Australia aren't they, or the Alsatian? You can't have an Alsatian in Western Australia. Got the chop about thirty years ago. German Shepherd, but they look a bit the same.

Borat explained that, because of their perceived aggressive qualities, German Shepherds needed to be, "trained like that because you know, they can, dogs can impose fear in some people."

Regional. Andy, Brad and Wynnie described attributes that for them, distinguished regional enculturation as a characteristic of their interaction with dogs. For example, Brad described himself as someone who was, "was born in the bush. I live in the bush, I work in the bush," and as someone who is, "in the game with animals." Wynnie compared the differences between people from urban regions that she called "city people" and those from regional areas that she called "the country people thing, you know. That's how they are, like they're kind of shy and quite reserved." Wynnie also likened these differences to dogs from different regions, and described Adonis as a, "city dog...He does paper runs...I mean if it was a cattle dog it would be different, but Adonis, yes, he's a city dog...City people and country people are really, really different...we are country bumpkins."

Brad also described how regional values and beliefs characterised his interactions with dogs at home where, "I don't even have them in the fence let alone in the bloody house." Brad's comments were echoed by Andy who explained that, "If the dog walked into his [Brad's] kitchen when they were eating he'd shoot it, that's the law of the land." Brad further described dogs as working animals and as commodities that, "I never pay...as they could get killed in our game. The dog could get killed or hurt."

Both Andy and Brad explained that farmers in regional areas used Bull Terriers to herd wild cattle and often cross-breed them with dingos. The combined intelligence, cunningness and killer instincts create what Andy described as, “wrecking machines mate. They got the cunningness of the killer instinct of dingo, and the smartness of the other.” Brad also explained the dingo as a wild dog, on which there was a bounty where, “you get twenty bucks [dollars] for him if you hit him on the head...well what used to be sheep country.” Brad said that dingos had a, “killer instinct, eh, their natural, they’ll kill your chook, they just can’t help themselves. They don’t get that out of them.” Brad’s description was echoed by Andy who said that dingos were a, “wild dog, they’re totally different to these town mongrels. He [the dingo] had killer instinct.”

Brad further explained that he would play with a working dog, but that he would not, “go out of my way to muck around with the dogs.” He also said that a barking dog indicated a problem, and that, “as far as I am concerned [barking dogs are] bad news, you don’t have barking dogs...where I come from, if a dog barks you got a problem.” These regional values and beliefs about dogs were accented by Brad’s comment that, “when you’re looking for a working dog, Chihuahua? I don’t know what you’d use it for, feed it to the croc?”

Personal enculturation. Borat and Andy described personal enculturation as a characteristic of their interaction with dogs. For example, Borat said that, because dogs were seen as part of the family, people want to treat them the same as other family members and that, “you wouldn’t leave your kid at home...why wouldn’t you take your dog with you?” Borat’s comments were echoed by Andy, who in the following interview excerpt, described dogs as heroes within the family:

“Well Taylor will tell you what Dukie did when you kids were in that pool pretending you were drowning. He dived straight in, mate, and he grabbed them

by the back of the hair gently or he dragged them by the wrists...and he swam them to the edge of the pool. Now you tell me how that comes out of like a wild dog. There's a lot we don't understand, eh? Mate, you got to train RAF dogs to do that.

Wynnie contrasted people's interaction with dogs, with people's use of technology, and likened computers to television that are, "very antisocial things aren't they really? They're totally antisocial, but it's a big part of everyone's life...it's an addiction." In contrast she explained that dogs may:

"Take a second to the computer and TV, cause that's just the way we live nowadays...the TV you know, you walk into any house, and the TV's a centre point, isn't it? I don't know how many people do actually have dogs. So nobody thinks to go and play with the dogs."

Social Axioms

Six students who were interviewed after the course described the way they perceived other people's disposition and interaction with dogs by using three social axioms that were represented in the form of enthymemes¹³.

The first axiom, described by Andy, Wynnie and Dan, might be stated as: People who like dogs are good people and therefore people who do not like dogs are not good people. For example, Andy explained that, "dogs know, mate. If you're a bad

¹³ An enthymeme is a concept from classical rhetoric that is used to describe an incomplete logical inference and takes the form of a syllogism where one part, the major or minor premise or the conclusion is missing. An enthymeme is also characterised as a plausible or likely inference, which contrasts with the logically binding inference of a perfect syllogism (Feldman, Skildbert, Brown, & Horner, 2004).

person they won't come near you. They sense it straight away. If you're a good natured person, they'll have no hassles with you." This was echoed by Wynnie who said that, "some people are dog people and some people aren't." Similarly, Dan explained that, "how people relate to dogs tells something about a person...In my life I've had relatives who couldn't build a relationship with dogs, and they tend to be not particularly nice people."

In the following interview excerpt, Andy explained the corollary of this axiom was that people whom he did not see interact with the dogs, were therefore not seen as people with whom he would socialise:

Well they're toffy-nosed bitches as far as I'm concerned. That dog tells me what sort of people they are. They haven't got the time to sit down, say hello, and give him a pat, and the rest of it mate, well, that tells me a lot. They're the sort of people I wouldn't associate with. Someone come into me house and kicked the dog in the gut, he'd never set foot in the house again.

Another corollary of this axiom for Andy was that because he did not see Alma interact with the dog, he believed that, "Alma didn't have a lot of time for him [the dog]. I think Alma would have preferred not to have him in that classroom...she's only got time for herself and no one else." For Wynnie, the corollary of this axiom was that Reggie, whom she saw as someone who did not like dogs, was also seen as someone who was not trustworthy, "because you know, when you're dealing with people there's always going to be a few prudes, a few people that don't approve, a few people that want to cause problems for everyone else."

The second axiom, described by Borat, might be stated as: People who like dogs care about other people and therefore people who do not like dogs cannot care about others. In describing this axiom, Borat explained that because he believed Morgan was,

“a person who doesn’t like dogs and doesn’t care about them, how much can you care about kids? You know, because I didn’t feel that she does.”

The third axiom, described by Leigh, Mary and Borat, was described by Leigh as, “people that like dogs are comfortable having them there, and the people that don’t like dogs aren’t comfortable having them there.” This was echoed by Mary and Borat, who explained that the corollary of this axiom was that: because they believed that Reggie had an allergy to dogs, she did not like dogs and therefore was not comfortable with having them in the classroom. For example, Mary explained that, “probably Reggie was the only one cause she said she had an allergy to pets, so, and she wasn’t as comfortable, didn’t seem as comfortable with them.”

Socialisation

Six students, Andy, Dan, Leigh, Morgan, Sharon and Wynnie, along with the teacher described how their interaction with the dogs was characterised by the way they aided in breaking the ice and providing a shared reference for conversation that was value-neutral. For example, Wynnie explained that the dogs were, “a little bit of an ice-breaker at the beginning, you know? You notice people standing around talking about the dogs, and talking to each other, talking about dogs, and I’ve got this dog, and I’ve got that dog.” Wynnie’s comments were echoed by Sharon who explained that the dogs were a, “talking point, and it got people together to talk about whether they had dogs or didn’t have dogs. [The dogs] gave them something to talk about...it got the group talking about something that was non-controversial.” Similarly, Dan explained that the dogs, “might have broken the ice initially, yes? Especially when we, that first four hours can be sometimes stressful when you’re getting to know the trainer, getting to know other people around you.”

In addition, Sam explained that the stray dogs also provided a reference point for social conversation amongst students. They asked questions such as: “Where did the other dogs come from, you know, are they strays, who do they belong to, you know? How dare they come in a steal his thunder?” Conversely, in the following interview excerpt Morgan explained that the dogs held the potential for the teacher to increase social interaction by encouraging students to change the direction in which they were looking:

Even if she had have gone to Lady, you know and given Lady a pat, and said, and started reading from there. Or taking group discussion from there which meant that all of us had to turn around this way which means I may have been able to have a little bit more interaction with Leigh and Mary, who were at the back all the time.

Negative Cases

Three students, Mary, Danni, and Brad, stated that they saw no observable evidence of benefits gained by interacting with the dogs. For example, Brad explained that his orientation towards dogs may have factored in the perceived benefits but that they, “might affect other people differently, people who like dogs. I’m not a dog person, you know. As I say, the dog didn’t mean nothing to me....I don’t even think it distracted me.”

In contrast, Danni surmised that there were benefits of interacting with the dogs, “where people are unwell, where people need perhaps a calming environment. But I can’t see with normal adult learning environment there how it benefits us. I can’t, I haven’t seen that anyway yet.” In the following interview excerpt Mary described that she did not derive any benefit from interacting with the dogs and implied a different orientation than the positive one stated in the pre-course questionnaire:

It doesn't bother me either way. Hasn't affected me in anyway particularly. I don't mind them being there, but I don't think it makes a big difference. Really, at all. Yes, I think it does. I think, for some people it's a very positive thing, it makes them feel more comfortable and at ease. But, for me personally it doesn't do anything. Well that for some people they may have been a nice pleasant distraction when it became uncomfortable. For me personally, it didn't make an awful lot of difference, but I think it probably did for some. No, but then I'm not cat mad so, I mean I quite like dogs, but I think it doesn't bother me either way so I can have them around me or not. I don't think it made any difference to the whole training experience.

During the morning break on the third day, and during informal conversation, Reggie revealed that she was a dog person and knew that dogs were beneficial in therapy situations, yet they made her anxious because she did not know what they were going to do. She said that they made her, "on edge," and that she was cautious when interacting with them. She also explained that she could feel her eyes irritated and started to cough when the dogs were near.

Repertory Grid Data

A total of seven repertory grids were completed for eight participants. Individual grids were completed for Borat, Danni, Leigh, Mary, Sam and Wynnie. However, Sharon and Dan did not have the time available to complete their grids individually. Therefore, rather than forego the data, the technique was modified to complete their grid as a couple. This was consistent with applications of the technique in group and couple situations in other contexts described by Mendoza (1985) and Pike (2007). The interpretation of the results for Sharon and Dan's grid should therefore be read with the

understanding that it represents a shared construct map and not the construing of Sharon and Dan as individuals.

Three students who agreed to participate in the repertory grid technique, Andy, Brad and Morgan, experienced difficulty in construing and contrasting differences with other students and the dogs. Therefore the technique was abandoned for these people. Brad and Morgan explained that they found it difficult to construe and contrast elements because they could not recall people's names, behaviours or characteristics. This was exemplified by Brad's comment that, "to me those fellows there could have been on the moon."

Leigh and Mary also found it difficult to construe and contrast elements, and to rate elements on constructs. Yet both agreed to continue with the repertory grid technique. These difficulties are illustrated in the following excerpt from Mary's interview and may bear on the interpretation of the analysis and results of these grids:

I can't see any real similarities or any real differences in those two...All pretty much the same as each other. I didn't see, there's not one that stands out that was you know, in the crowd that stood out as this lot, as being extra loud or extra quiet, to me.

Leigh's difficulty was distinguished by the number of mid-range ratings given across all elements, except for Lady, Adonis, Buddy and Reggie. This may have been because of her reluctance to judge others and her desire to maintain harmony. For example, Leigh explained that, "I find it hard to perceive cause I try really hard not to judge people and that's sort of, I don't like to do that." Similarly, Mary also implied a reluctance to judge others, a desire to see other people's points of view and to maintain harmony.

Summary of Constructs and Principal Components

Reported in this section is an analysis of the principal components and biplots for each repertory grid. A sample of the detailed analytical process used to extract and understand these components is reported at Appendix M. This analysis included: rich descriptions of the meaning participants ascribed to each construct, bivariate statistics including, construct and element correlations, and cluster analyses.

Reported at Table 29 is a summary of the constructs and factor loadings extracted from each grid. These constructs and factor loadings appear to suggest three patterns of how people constructed their environment. The first contrasts characteristics of Outgoing, Gregarious and Approachable with Reserved, Aloof and Distant. The second pattern contrasts characteristics of Easy-Going, Accepting and Trusting with Serious and Vulnerable. The third contrasts Casual and Unstructured with Disciplined, Formal and Intense. This may suggest that people viewed their learning environment largely through a social lens.

Reported at Table 30 is a summary of the principal components extracted from each participant's repertory grid. The list of first components appears to emphasise a social construct of the learning environment by contrasting characteristics of Open, Sociable, Outgoing and Trustworthy with Critical, Reserved, Unapproachable and Distant. The list of second components contrasts characteristics of Spontaneous, Free, Trust and Accepting with Disciplined, Structured, Insensitive and Critical.

Borat

Unrotated Eigenvalues

Reported at Table 31 are the eigenvalues for each principal component extracted from Borat's grid. Two principal components account for 71.35% of the total variance. This means that 28.65% of the variance is not accounted for by the two principal

Table 29

Summary of Constructs and Factor Loadings

Constructs		Factor Loadings	
Emergent Pole	Implicit Pole	PC1	PC2
Borat			
Active	Quiet	0.06	-0.89
Experienced Altruistic	Novice Seeking Altruism	0.12	-0.33
Excited Naïve	Content Experienced	0.64	-0.67
Committed Passion	Distant Removed	0.22	-0.88
Approachable Trustworthy	Wary	0.76	-0.34
Happy Participative	Holds Back	0.70	-0.51
Down-To-Earth	Aloof	0.88	-0.24
Wants To Be Here	Needs To Be Here	0.80	-0.37
Accepting of others	Vulnerable	0.78	0.41
Danni			
Drawn Together	Separated	0.48	0.62
Communicator	Loner	0.83	0.44
Easy Going	Serious	0.84	0.46
Immature	Mature	0.29	0.90
Warm	Cold	0.83	0.43
Guarded Closed	Open	-0.87	-0.22
Fun Happy-Go-Lucky	Not Flippant	0.71	0.57
Unstructured	Judgemental	0.38	0.87

Constructs		Factor Loadings	
Emergent Pole	Implicit Pole	PC1	PC2
Leigh			
Reserved	Outgoing	-0.73	-0.05
Socialise	Serious	0.73	-0.37
Approachable	Unapproachable	0.72	-0.28
Simple	Complicated	0.29	-0.88
Difficult to Get To Know	Open	-0.86	0.24
Interesting	Uninteresting	0.70	0.18
Disciplined	Rowdy	-0.69	-0.48
Talks To Others	Isolated	0.69	-0.30
Obedient Loyal	Without Responsibility	-0.03	-0.92
Mary			
Reserved	Amusing	-0.30	-0.83
Tactful	Outspoken	-0.89	0.35
Socialiser	Evaluator	0.86	0.27
Friendly	Stranger	-0.09	0.89
Enthusiastic	Unenthusiastic	0.85	0.23
Sam			
Reserved	Confident Outgoing	-0.85	-0.44
Lovable Character	Unapproachable	0.26	0.88
Out There Initiator	Responder	0.68	0.47
Strong in Opinions	Strong in Principles	0.87	0.12

Constructs		Factor Loadings	
Emergent Pole	Implicit Pole	PC1	PC2
Young Excitable	Mature Settled	0.51	-0.05
Pragmatic Disaffected	Attention Seeking	-0.55	0.63
Friendly Lovable	Spoilt Brat	-0.18	0.87
Street Wise	Sheltered	0.18	0.86
External Recognition	Internal Reward	0.83	-0.25
	Sharon and Dan		
Commands Attention	Observes	0.87	-0.24
Connected	Disconnected	0.90	0.23
Gregarious Outgoing	Cautious	0.98	0.01
Calm Relaxing	Engaging	-0.06	0.98
Quiet Aloof	People Seeking	-0.97	-0.08
Quiet	Talkative	-0.97	0.02
	Wynnie		
Happy Energetic	Formal Precise	0.86	0.32
Outspoken Out-of-Turn	Disciplined	0.91	0.04
Philosophical Metaphysical	Practical	0.62	0.07
Casual	Intense	-0.92	-0.23
Purpose To Be Here	Not Sure Why Here	0.00	0.96
Tolerant Patient	Not Accepting Stroppy	0.14	0.84

Table 30

Summary of Principal Components

Principal component 1		Principal component 2	
Emergent pole	Implicit pole	Emergent pole	Implicit pole
Borat			
Positive Trustworthy	Critical Distant	Compassion	Aggressive
Social	Reserved	Respect	Insensitive
Danni			
Open Warm	Critical Reserved	Spontaneous	Disciplined
Optimism	Practical	Flexible	Structured
Unstructured			
Leigh			
Sociable Traditional	Reserved Original	Dependent	Independent Free
Approachable	Unapproachable	Obligated Agent	Agent
Mary			
Extroverted Social	Reserved Social	Trust	Unknown
Optimism	Cynicism		
Sam			
External Reward	Internal Values	Unapproachable	Approachable
Driven	Driven	Not Social	Attractive
Sharon and Dan			
Active Social	Reserved Distant	Approachable	Active Stimulated
Calm			

Principal component 1		Principal component 2	
Emergent pole	Implicit pole	Emergent pole	Implicit pole
Wynnie			
Spontaneous	Disciplined	Purpose Accepting	Desultory Critical
Extroverted	Reserved Practical		
Optimism			

components. Application of the Kaiser criterion¹⁴ indicates that three components should be included in the factor and principal component analyses. However, for practical purposes only two components have been included. Therefore the factor and principal component analyses should be interpreted mindful of a third significant component that accounts for 13.67% of the variance in the grid.

Factor Loadings

Reported at Table 32 are the factor loadings for each component. The first component appears to be heavily loaded on Constructs 5, 6, 7, 8 and 9, and to a lesser extent on Construct 3. The inclusion of Construct 9 is incongruent with the construct correlations. It is the only construct that is heavily loaded on the second component and therefore appears to be describing different facets. This suggests that it should not be

¹⁴ According to Garson (2008) variables are standardised to have means of 0.00 and variances of 1.00. Therefore an eigenvalue of less than 1.00 means that a component accounts for less than one construct and can be safely ignored. This is known as the Kaiser criterion or K1 rule.

Table 31

Eigenvalues and Component Variance for Borat's Grid

Component	Eigenvalue	% Variance	% Cumulative variance	Scree plot
PC_1	4.77	52.98	52.98	*****
PC_2	1.65	18.37	71.35	*****
PC_3	1.23	13.67	85.01	****
PC_4	0.46	5.11	90.12	**
PC_5	0.38	4.23	94.35	**
PC_6	0.25	2.75	97.10	**
PC_7	0.11	1.24	98.33	*
PC_8	0.08	0.85	99.18	*
PC_9	0.07	0.82	100.00	*

included in the description of this component. These factor loadings suggest that the first component may be characterised by approachability, trustworthiness, participative, positive energy and emotion, outgoing, and people who are grounded and personally motivated to attend the course. The extroverted facet of this construct is supported by the heavy negative loading on Constructs 1 and 4. These factor loadings suggest that the contrasting pole of this component may be characterised by people Borat saw as distant and removed, less trusting, reserved, “holding back,” aloof, and obligated to attend. These descriptions suggest that this component may be labeled Positive Trustworthy Social—Critical Distant Reserved.

Table 32

Factor Loadings for Borat's Grid

	Construct		Factor loading	
	Emergent pole	Implicit pole	PC 1	PC 2
1. Active	Quiet		0.06	-0.89
2. Experienced Altruistic	Novice Seeking Altruism		0.12	-0.33
3. Excited Naïve	Content Experienced		0.64	-0.67
4. Committed Passion	Distant Removed		0.22	-0.88
5. Approachable Trustworthy	Wary		0.76	-0.34
6. Happy Participative	Holds Back		0.70	-0.51
7. Down-to-Earth	Aloof		0.88	-0.24
8. Wants to be Here	Needs to be Here		0.80	-0.37
9. Accepting Helping	Vulnerable		0.78	0.41

The second component appears to be heavily loaded only on Construct 9, which suggests that this component may be characterised by compassion, acceptance and respect. These factor loadings also suggest that the contrasting pole may be characterised by self-concern, aggressive, conflict creators. These descriptions suggest that this component may be labeled Compassion Respect—Aggressive Insensitive.

Biplot

The biplot reported in Figure 5 presents a graphical picture of Borat's construct space. It places both the constructs and elements plotted against the two principal components. All elements and constructs except Vulnerable—Accepting, appear along

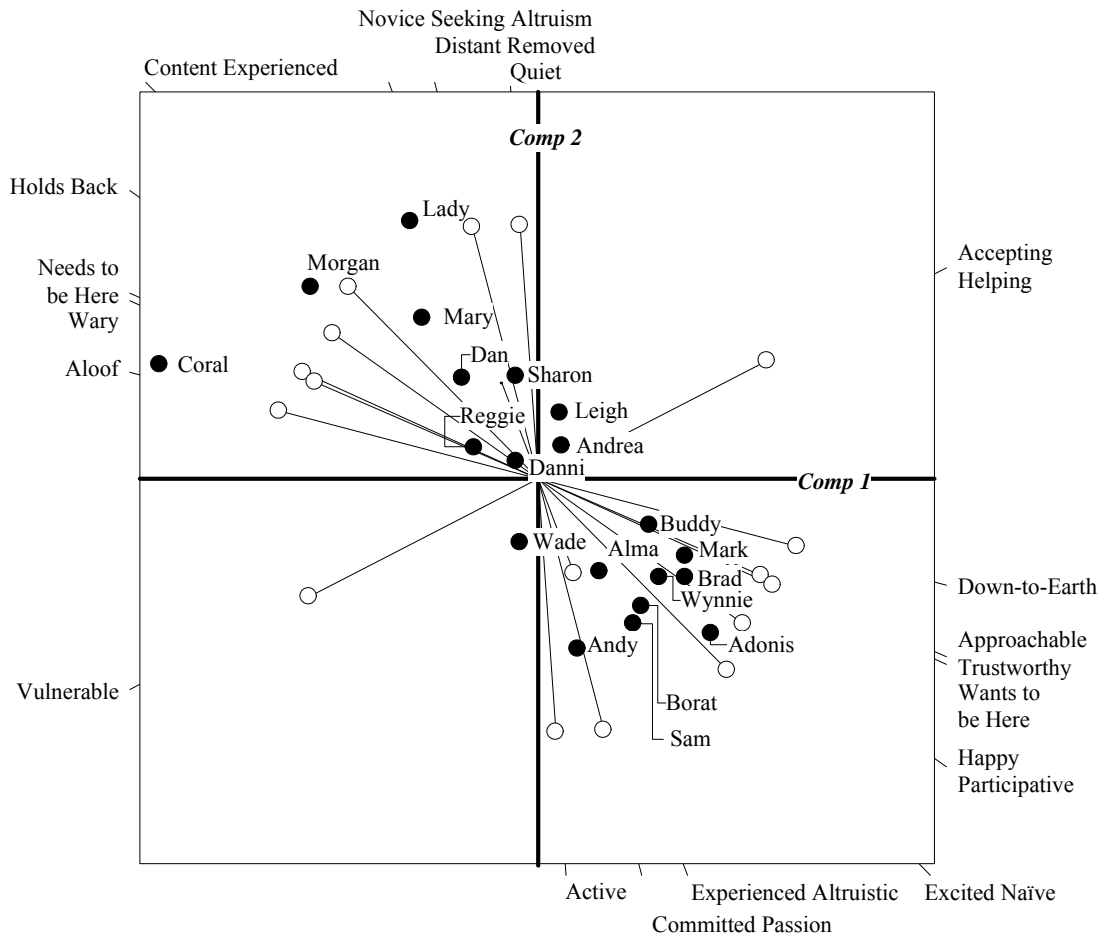

Figure 5. Biplot for Borat's repertory grid.

a diagonal line from the top left to the bottom right. This suggests a dichotomous structure of Borat's construct space. This pattern also suggests that Borat used both components dynamically to create groups of elements either side of the centre that are the inverse of others. It may also suggest that the two principal components operated in a relative manner. For example, where elements were construed high on the Compassion Respect component, they were also construed high on the Positive Trustworthy Social component. Conversely where elements were construed high on the Aggressive Intensive component, they were also construed high on the Critical Distant Reserved component. All elements therefore fall within either the top left or bottom right quadrants of the biplot. This may suggest a simple construct system, and "black-

and-white” thinking. The biplot also reveals that all constructs are moving towards the centre, which suggests they may not have been clearly defined within Borat’s construct space.

The one construct that appears obliquely across the dichotomous construct space is Vulnerable—Accepting. However, no elements are close to this construct. This may suggest that this construct was of less importance than others in defining Borat’s construct space. Coral stands out as separate to all other elements as the most critical, aloof distant and reserved. The clustering of elements in the bottom right quadrant suggests that many of these elements, including Borat himself, may have been seen as positive, trustworthy social and compassionate. Within this cluster are Adonis and Buddy who are located inversely to Lady who is located in the top left quadrant. This may also suggest that Borat saw Adonis and Buddy as similar to himself and Lady least like himself.

Danni

Unrotated Eigenvalues

Reported in Table 33 are the eigenvalues for each principal component extracted from Danni’s grid. Two principal components account for 84.38% of the total variance. This means that 15.62% of the variance is not accounted for by the two principal components. This is within acceptable limits for analysis and can be validated through the scree plot and application of the Kaiser criterion. The factor and principal component analyses should therefore be interpreted, mindful that the first principal component accounts for 75.24% of the total variance. Therefore, Danni’s construct space may be understood largely in terms of this one component. This echoes the dichotomous structure of Danni’s construct space that is indicated by the strong positive correlations between many of the constructs.

Table 33

Eigenvalues and Component Variance for Danni's Grid

Component	Eigenvalue	% Variance	% Cumulative variance	Scree plot
PC_1	6.02	75.24	75.24	*****
PC_2	0.73	9.14	84.38	***
PC_3	0.51	6.40	90.78	**
PC_4	0.30	3.80	94.59	**
PC_5	0.17	2.08	96.67	*
PC_6	0.15	1.88	98.55	*
PC_7	0.08	1.01	99.56	*
PC_8	0.03	0.44	100.00	*

Factor Loadings

Reported in Table 34 are the factor loadings for each component. The first component appears to be heavily loaded on Constructs 2, 3 and 5, and to a lesser extent on Construct 7. This suggests that this component may be characterised by interest in interacting with others, spontaneity, a sense of humour, easy to communicate with, open and down-to-earth, and emotionally and socially warm, with a facet of fun-loving optimism. The description of this component is supported by the heavy negative loading on Construct 6. These factor loadings may suggest that the contrasting pole of this component may be characterised by avoiding social interaction, practical, task-focused, critical and unapproachable. These descriptions suggest that this component may be labeled Open Warm Optimism—Critical Reserved Practical.

Table 34

Factor Loadings for Danni's Grid

Construct		Factor loading	
Emergent pole	Implicit pole	PC 1	PC 2
1. Drawn Together	Separated	0.48	0.62
2. Communicator	Loner	0.83	0.44
3. Easy Going	Serious	0.84	0.46
4. Immature	Mature	0.29	0.90
5. Warm	Cold	0.83	0.43
6. Guarded Closed	Open	-0.87	-0.22
7. Fun Happy-go-Lucky	Not Flippant	0.71	0.57
8. Unstructured	Judgemental	0.38	0.87

The second component appears to be heavily loaded on Constructs 4 and 8. This suggests that this component may be characterised by a lack of responsibility and discipline, spontaneity, flexibility, and energised by many things. These factor loadings suggest that the contrasting pole of this component may be characterised by structure, discipline, task-focused. These descriptions suggest that this component may be labeled Spontaneous Flexible Unstructured—Disciplined Structured.

Biplot

The biplot reported at Figure 6 presents a graphical picture of Danni's construct space. It places both the constructs and elements plotted against the two principal components. All elements and constructs appear along a diagonal line from the bottom left to the top right. This suggests a dichotomous structure of Danni's construct space.

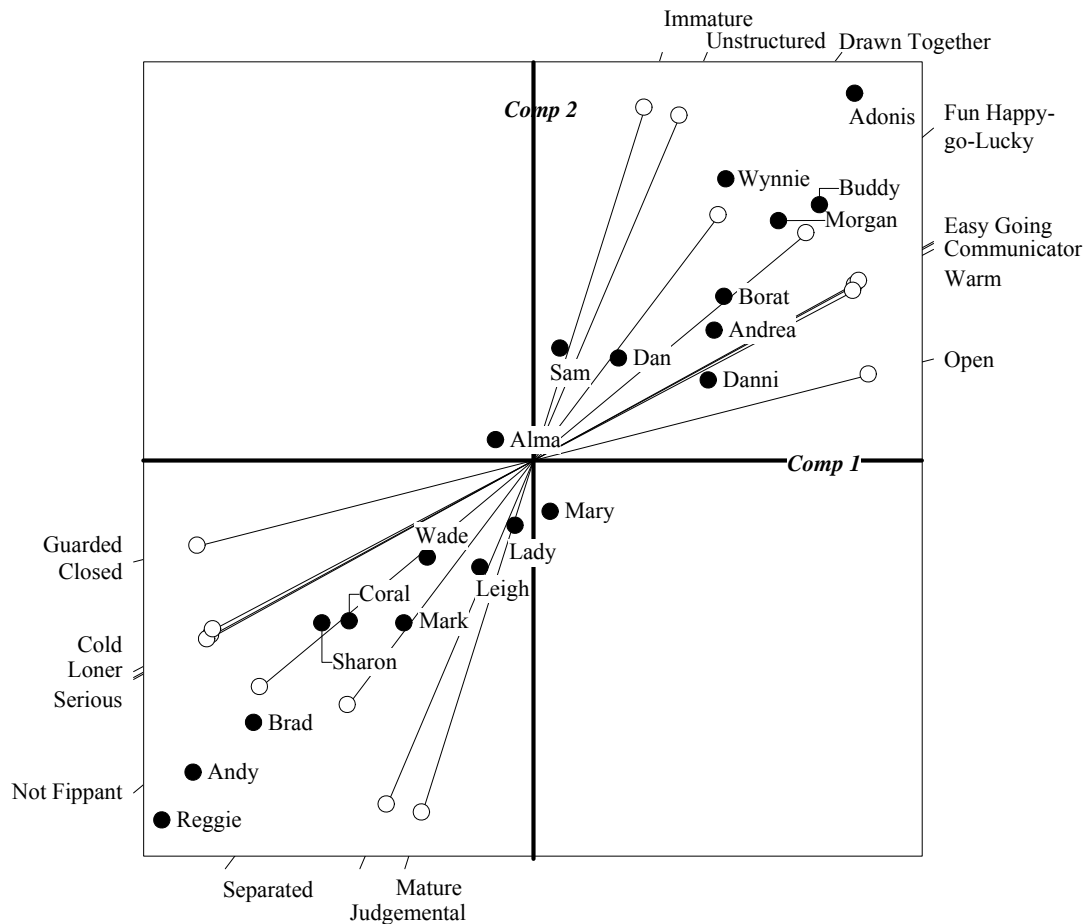

Figure 6. Biplot for Danni's repertory grid.

This pattern also suggests that Danni used both components dynamically to create groups of elements either side of the centre that are the inverse of others. It may also suggest that the two principal components operated in a relative manner. For example, elements that were construed low on the Spontaneous Flexible Unstructured component, were also construed low on the Open Warm Optimism component. Conversely elements that were construed high on the Spontaneous Flexible Unstructured component, were also construed as high on the Open Warm Optimism component. All elements therefore fall within either the bottom left or top right quadrants of the biplot, except Alma and Mary who are close to the centre. This may suggest a simple construct system, and "black-and-white" thinking.

Adonis and Buddy were seen as the most spontaneous, flexible, unstructured, open warm and optimistic. Adonis is also close to the extremes of both components. Danni placed herself in the same quadrant as Buddy and Adonis, which suggests she may have seen herself as open warm and optimistic, yet only slightly spontaneous flexible and unstructured. Danni felt more connected to Buddy than any other dog, yet he is located a distance away from her on the biplot.

Alma, Mary and Lady are close to the centre. This suggests that they may not have been clearly defined within Danni's construct space. No dogs are located towards the Critical Reserved Practical component or the Disciplined Structured component. There are no elements located away from the centre in either of the upper left or bottom right quadrants. This may suggest that Danni, may not have seen people as open warm, optimistic, and disciplined and structured at the same time. Similarly, she may not have seen people as spontaneous, flexible and unstructured, and critical reserved and practical at the same time. This may suggest that these components are exclusive of each other, and further points towards a simple construct system.

Leigh

Unrotated Eigenvalues

Reported at Table 35 are the eigenvalues for each principal component extracted from Leigh's grid. Two principal components account for 67.86% of the total variance. This means that 32.14% of the variance is not accounted for by the two principal components. This is within acceptable limits for analysis, and can be validated through the scree plot and application of the Kaiser criterion. However, the factor and principal component analyses should be read mindful that 32.14% of the variance is not accounted for by the two principal components.

Table 35

Eigenvalues and Component Variance for Leigh's Grid

Component	Eigenvalue	% Variance	% Cumulative variance	Scree plot
PC_1	4.06	45.16	45.16	*****
PC_2	2.04	22.70	67.86	*****
PC_3	0.88	9.83	77.69	***
PC_4	0.58	6.45	84.14	**
PC_5	0.52	5.73	89.87	**
PC_6	0.42	4.61	94.49	**
PC_7	0.31	3.42	97.91	**
PC_8	0.13	1.43	99.34	*
PC_9	0.06	0.66	100.00	*

Factor Loadings

Reported in Table 36 are factor loadings for each component. The first component appears to be heavily loaded on Constructs 2, 3, 6 and 8. This suggests that the first component may be characterised by sociability, quiet extroverted sociability, friendliness, shared interests and approachability. The extroverted sociability facet of this component is supported by the heavy negative loading on Constructs 1 and 5. The heavy negative loading on Construct 7 may suggest that within the quiet extroverted sociability description of this component, there may be a facet of discipline and conforming to expected social behaviour. For example, Leigh described people who

Table 36

Factor Loadings for Leigh's Grid

	Construct		Factor loading	
	Emergent pole	Implicit pole	PC 1	PC 2
1. Reserved	Outgoing		-0.73	-0.05
2. Socialise	Serious		0.73	-0.37
3. Approachable	Unapproachable		0.72	-0.28
4. Simple	Complicated		0.29	-0.88
5. Difficult to Get to Know	Open		-0.86	0.24
6. Interesting	Uninteresting		0.70	0.18
7. Disciplined	Rowdy		-0.69	-0.48
8. Talks to Others	Isolated		0.69	-0.30
9. Obedient Loyal	Without Responsibility		-0.03	-0.92

were not, “disciplined really in terms of sort of going where he wasn’t supposed to go and that type of thing.” These factor loadings suggest that the contrasting pole of this construct may be characterised by introverted seriousness, inapproachability, reserved and difficult to get to know. These descriptions suggest that this component may be labeled Sociable Traditional Approachable—Reserved Original Unapproachable.

The second component appears to be heavily negatively loaded on Construct 9. This suggests that the second component may be characterised by an absence of obligations, loyalty or responsibility towards others. This appears to be different to the logical opposite, which is irresponsible. These factor loadings suggest that the contrasting pole of this construct may be characterised by obligation, loyalty and responsibility towards

others. They also suggest that this component may be labeled Dependent Obligated Agent—Independent Free Agent. A further clue to understanding this component may lie in what appears to be the heavy negative loading on Construct 4. This may imply that Dependent Obligated Agents contain a facet of being easy to understand and that Independent Free Agents by contrast were more complicated and may not have conformed to traditional expectations. The construct correlations appear to support these factor loadings.

Biplot

The biplot reported at Figure 7 presents a graphical picture of Leigh's construct space. It places both the constructs and elements plotted against the two principal components. The spread of elements and constructs across the biplot may suggest a complex structure of Leigh's construct space.

The cluster of elements around the centre suggests that these elements may not have been well defined within Leigh's construct space. Conversely, it may echo Leigh's difficulty in discrimination, construct elicitation and attribute evaluation. Those elements that appear to be more clearly defined are located towards the poles of both components. These are the three dogs, Coral, Dan, Reggie and Sharon. Sharon and Dan are located towards the Reserved and Uninteresting constructs, which may suggest that these were important constructs in defining these people. The dogs appear to be the most clearly defined elements, since they are placed closest to the poles of each component.

Buddy and Adonis are not close to any constructs. This may suggest that no single construct was important in defining these elements. Located in the same quadrant are Sharon, Dan and Lady. Lady is placed close to the Disciplined construct, which may suggest that this was an important construct in defining Lady. Conversely Buddy

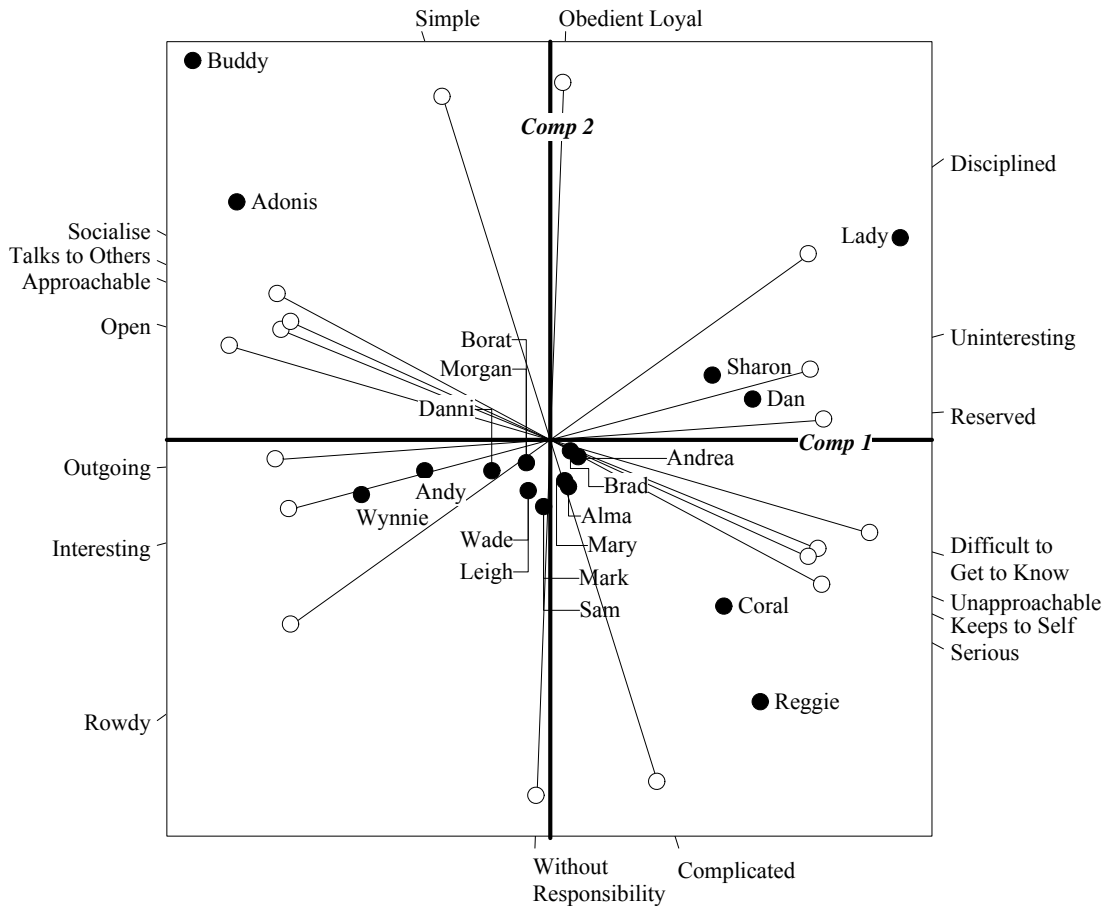

Figure 7. Biplot for Leigh’s repertory grid.

and Adonis are clustered together at the extreme opposite poles of both components. This may suggest that Leigh saw them as being the most social, approachable, friendly, loyal and obedient of all elements, and more social and approachable than either herself or Lady. Buddy and Adonis are the only elements to occupy space within the top left quadrant of the biplot.

Coral and Reggie are clustered together in the bottom right quadrant of the biplot and therefore stand alone as separate and different to all other elements. This suggests that Leigh defined these people as the most unapproachable, reserved and independent free agents within the group, and unlike any other element. Several constructs are located towards the centre, which may indicate that they were less well

defined within Leigh's construct space. Conversely, it may also echo Leigh's difficulty in discrimination, construct elicitation and attribute evaluation.

Mary

Unrotated Eigenvalues

Reported at Table 37 are the eigenvalues for each principal component extracted from Mary's grid. Two principal components account for a total of 81.67% of the total variance in the grid. This means that 18.33% of the variance is not accounted for by the two principal components. This variance is within acceptable limits for analysis and can be validated through the scree plot and application of the Kaiser criterion.

Factor Loadings

Reported in Table 38 are the factor loadings for each component. The first component appears to be heavily loaded on Constructs 3 and 5. This suggests that the first component may be characterised by outward focused, social energy, excitement and optimism drawn from what is happening around and being involved in what they are doing. These factor loadings suggest that the contrasting pole of this component may be characterised by negative disinterested energy where people are cynical, unenthusiastic, and cautious sociability, where people are distrusting, and observe and evaluate before acting. They also suggest that this component may be labeled Extroverted Social Optimism—Reserved Social Cynicism.

The second component appears to be heavily loaded on Construct 4. This suggests that this component may be characterised by trust, and people who were seen as friendly, comfortable to talk to and who, "mix well with others." Mary was unable to identify the contrasting pole of Construct 4. Therefore this remains unknown. The description of this component may suggest a label of Trust—Unknown.

Table 37

Eigenvalues and Component Variance for Mary's Grid

Component	Eigenvalue	% Variance	% Cumulative variance	Scree plot
PC_1	2.46	49.29	49.29	*****
PC_2	1.62	32.38	81.67	*****
PC_3	0.51	10.25	91.92	***
PC_4	0.27	5.36	97.28	**
PC_5	0.14	2.72	100.00	**

Biplot

The biplot reported at Figure 8 presents a graphical picture of Mary's construct space. It places both the constructs and elements plotted against the two principal components. The spread of elements and constructs across the biplot suggests a complex structure of Mary's construct space. No elements or constructs appear close to the centre. This may suggest clarity in Mary's construct space despite the difficulties she experienced in discrimination, construct elicitation and attribution. There is a large cluster of elements towards the Reserved Social Cynicism pole of Component 1, spread mid-way across Component 2. This may suggest that Mary saw these people as being similar to each other, as reserved observers who stood back and waited to see what happened before engaging with others, and as unfriendly and unapproachable. Leigh and Morgan are tightly clustered together with Mary, which may suggest that Leigh and Morgan were seen as most like herself. The clustering of elements suggests that Mary may have largely seen the group seen as introverted, reserved observers.

Table 38

Factor Loadings for Mary's Grid

Construct		Factor loading	
Emergent pole	Implicit pole	PC 1	PC 2
1. Reserved	Amusing	-0.30	-0.83
2. Tactful	Outspoken	-0.89	0.35
3. Socialiser	Evaluator	0.86	0.27
4. Friendly	Stranger	-0.09	0.89
5. Enthusiastic	Disinterested	0.85	0.23

Lady appears in the top right quadrant diagonally opposite Adonis and Buddy, who appear in the lower left quadrant. This may suggest that Mary saw Lady as the opposite of Adonis and Buddy and as reserved and largely unknown in terms of friendliness. It may also suggest that Adonis and Buddy were seen as enthusiastic, excited, involved, quick to socialise, friendly and providing amusing comic relief. Buddy and Adonis are located close to Wynnie and Andy. This may suggest Mary saw them as similar. Coral stands alone and separate from other elements, and shares the top left quadrant with only Reggie.

*Sam**Unrotated Eigenvalues*

Reported at Table 39 are the eigenvalues for each principal component extracted from Sam's grid. Two principal components account for 72.03% of the total variance in the grid. This means that 27.97% of the variance is not accounted for by the two

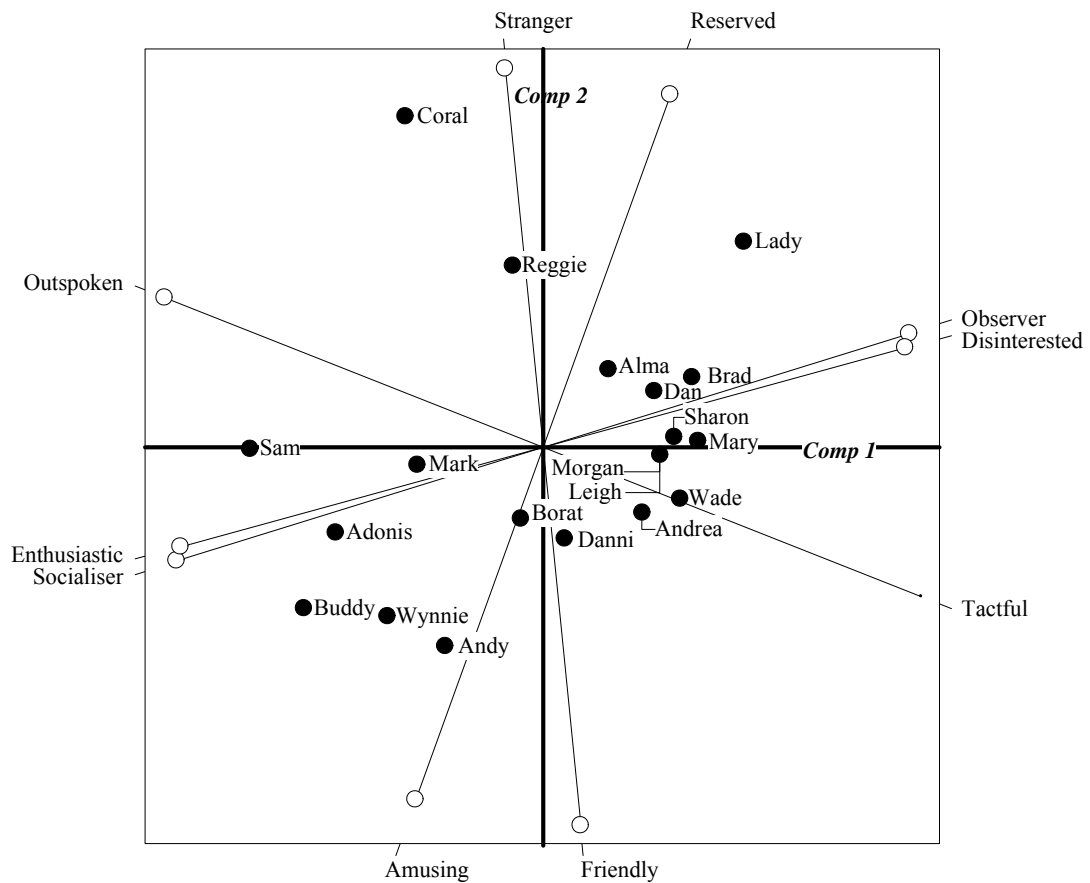

Figure 8. Biplot for Mary's repertory grid.

principal components. Application of the Kaiser criterion indicates that three components should be included in the factor and principal component analyses for this grid. However, for practical purposes, only two components have been included. The factor and principal component analyses should therefore be interpreted mindful of a third component that accounts for 12.71% of the total variance.

Factor Loadings

Reported at Table 40 are the factor loadings for each component. The first component appears to be heavily loaded on Constructs 4 and 9. This suggests that the first component may be characterised by external views and opinions, eager to please others and seeking outward signs of approval. The extroverted facet of this component is supported by the heavy negative loading of Construct 1. These factor loadings may

Table 39

Eigenvalues and Component Variance for Sam's Grid

Component	Eigenvalue	% Variance	% Cumulative variance	Scree plot
PC_1	3.70	41.13	41.13	*****
PC_2	2.78	30.90	72.03	*****
PC_3	1.14	12.71	84.74	****
PC_4	0.50	5.58	90.32	**
PC_5	0.32	3.51	93.83	**
PC_6	0.27	3.02	96.85	**
PC_7	0.11	1.26	98.11	*
PC_8	0.10	1.13	99.24	*
PC_9	0.07	0.76	100.00	*

also suggest that the contrasting pole of this component may be characterised by internal principles and values, and internal reward and recognition. Furthermore they may suggest that this component may be labeled External Reward Driven—Internal Values Driven. The second component appears to be heavily loaded on Constructs 2, 7 and 8. This suggests that this component may be characterised by trust, approachability, sociability, social attractiveness and experience in dealing with unexpected events. These factor loadings suggest that the contrasting pole of this construct may be described in terms of unapproachable, dependable on others. They may also suggest that this component may be labeled Approachable Attractive—Unapproachable Not Social.

Table 40

Factor Loadings for Sam's Grid

Emergent pole	Construct	Factor loading	
	Implicit pole	PC 1	PC 2
1. Reserved	Confident Outgoing	-0.85	-0.44
2. Lovable Character	Unapproachable	0.26	0.88
3. Out There Initiator	Responder	0.68	0.47
4. Strong in Opinions	Strong in Principles	0.87	0.12
5. Young Excitable	Mature Settled	0.51	-0.05
6. Pragmatic Disaffected	Attention Seeking	-0.55	0.63
7. Friendly Lovable	Spoilt Brat	-0.18	0.87
8. Street-wise	Sheltered	0.18	0.86
9. External Recognition	Internal Reward	0.83	-0.25

Biplot

The biplot reported at Figure 9 presents a graphical picture of Sam's construct space. It places both the constructs and elements plotted against the two principal components. The spread of elements and constructs across the biplot may suggest a complex structure of Sam's construct space.

The three dogs are located separately to each other. Adonis is seen as one of the most extroverted elements. He is also seen as trusting and approachable. Lady and Buddy on the other hand are located in the bottom right corner. However Lady is located closer to the Introverted pole of Component 1, and Buddy is located closer to the Not Social Unapproachable pole of Component 2. This may suggest that these two

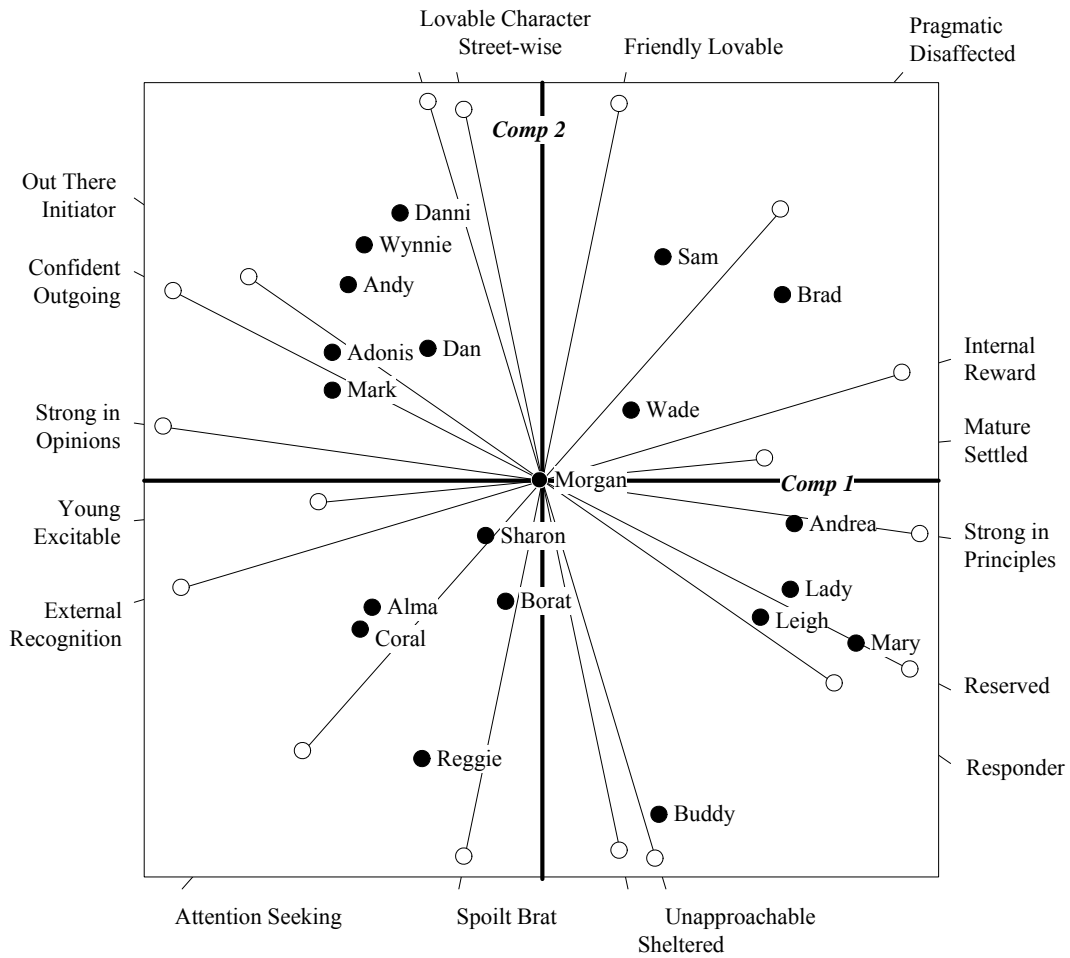

Figure 9. Biplot for Sam’s repertory grid.

dogs were seen as different to Adonis. However, Sam also saw them as different to each other. Lady was seen as more reserved and less unapproachable, and Buddy was seen as more unapproachable and less reserved. Buddy is located separately to other elements, which suggests that Sam saw him differently to all other elements.

Located towards the top left of the grid are elements that Sam saw as most extroverted, and at the same time, most approachable and trusting. These elements include Danni, Wynnie, Andy, Adonis, Dan and Mark. Adonis is the only dog that Sam saw as being Extroverted and Approachable Trusting, which during the dialogue discussion she expressed as being, “the most fun.”

Borat, Morgan, Sharon and Wade, are located close to the centre of the biplot. This suggests that these people may not have been well defined within Sam's construct space. The construct Young Excitable is also located closer to the centre than any other construct. This suggests that this construct may have been of less importance in defining Sam's construct space. Alma, Coral and Reggie are located together in the bottom left quadrant of the biplot. This suggests that these people were seen as more Extroverted. However they were also seen as Not Social or Approachable. Reggie and Buddy are located furthest down on the second component, and stand apart from all other elements. This may suggest Sam saw Reggie and Buddy as the most Unapproachable, Not Social elements, and Not Trusting in comparison to others elements. Buddy is located close to the Unapproachable construct, which may suggest that this may have been an important construct in defining how Sam saw him.

Clustered together with Leigh, Mary and Andrea is Lady. These elements are located towards the introverted pole of Component 1, and at the same time, located towards the Not Social Unapproachable pole of the second component. Though Lady was seen as more Introverted and Not Social Unapproachable compared to Adonis, and therefore possibly not as much fun; she nevertheless appeared to be the dog to which Sam felt most connected. This may suggest that for Sam fun was not an important element in connecting and forming a strong positive relationship with the dogs in the classroom.

Sam places herself distant from other elements including all three dogs, and shares the top right hand quadrant with only two other elements. This may suggest that Sam saw herself as being located moderately towards the Introverted pole of Component 1, and at the same time also moderating towards the Approachable Trusting pole of Component 2. This suggests that Sam saw all other Introverted elements, except

Brad, as being Not Social Unapproachable and not trusting.

Sharon and Dan

Unrotated Eigenvalues

Reported in Table 41 are the eigenvalues for each principal component extracted from Sharon and Dan's grid. Two principal components account for 91.5% of the total variance. This means that only 8.5% of the variance is not accounted for by the two principal components. This is within acceptable limits for analysis and can be validated through the scree plot and application of the Kaiser criterion. The factor and principal component analyses should be interpreted mindful that the first principal component accounts for 73.45% of the total variance. Therefore Dan and Sharon's shared construct space can be understood largely in terms of this one component. This echoes the dichotomous construction of Dan and Sharon's shared construct space that is indicated by the pattern of strong positive and negative correlations shared between the constructs.

Factor Loadings

Reported in Table 42 are the factor loadings for each component. The first component appears to be positively loaded on Constructs 1, 2, and 3, and heavily negatively loaded on constructs 5 and 6. This suggests that the first component may be characterised by active external energy, high sociability, active engagement, initiators of interactions, relationship building, free speaking and talkativeness. These factor loadings also suggest that the contrasting pole of this component may be characterised by reflective observers, separated, disconnected, cautious, distant from others, and quiet. They may also suggest that this component may be labeled Active Social—Reserved Distant.

Table 41

Eigenvalues and Component Variance for Sharon and Dan's Grid

Component	Eigenvalue	% Variance	% Cumulative variance	Scree plot
PC_1	4.41	73.45	73.45	*****
PC_2	1.08	18.05	91.50	*****
PC_3	0.29	4.89	96.39	**
PC_4	0.09	1.54	97.94	*
PC_5	0.08	1.29	99.22	*
PC_6	0.05	0.78	100.00	*

The second component appears to be heavily loaded only on Construct 4. This suggests that this component may be characterised by approachability and calmness and the contrasting pole by active, stimulated and positively stressed. These factor loadings suggest that this component may be labeled Approachable Calm—Active Stimulated.

Biplot

The biplot reported in Figure 10 presents a graphical picture of Sharon and Dan's shared construct space. It places both the constructs and elements plotted against the two principal components.

The biplot reveals a dichotomous structure of Dan and Sharon's shared construct space. All elements and constructs appear along the horizontal line that represents the first component. This suggests that Dan and Sharon's construct space was constructed largely in terms of Active Social—Reserved Distant. There are no elements towards the extreme poles of the second component. This supports a

Table 42

Factor Loadings for Sharon and Dan's Grid

	Construct		Factor loading	
	Emergent pole	Implicit pole	PC 1	PC 2
1. Commands Attention	Observes		0.87	-0.24
2. Connected	Disconnected		0.90	0.23
3. Gregarious Outgoing	Cautious		0.98	0.01
4. Calm Relaxing	Engaging		-0.06	0.98
5. Quiet Aloof	People Seeking		-0.97	-0.08
6. Quiet	Talkative		-0.97	0.02

dichotomous structure of Dan and Sharon's shared construct space. It also suggests that the second component was of less importance in locating elements within their construct space. This dichotomous spread of constructs and elements may suggest a simple construct system for Dan and Sharon, and a "black-and-white" mode of thinking.

Alma, Borat and Dan are located close to the centre of the biplot. This may suggest that these people were not well defined. The remaining elements are divided equally along the Active Social—Reserved Distant poles of Component 1. Adonis and Wade are located towards the Active Social pole of Component 1 and towards the middle of Construct 2. This may suggest that for Dan and Sharon, these elements were construed largely in terms of their active social engagement.

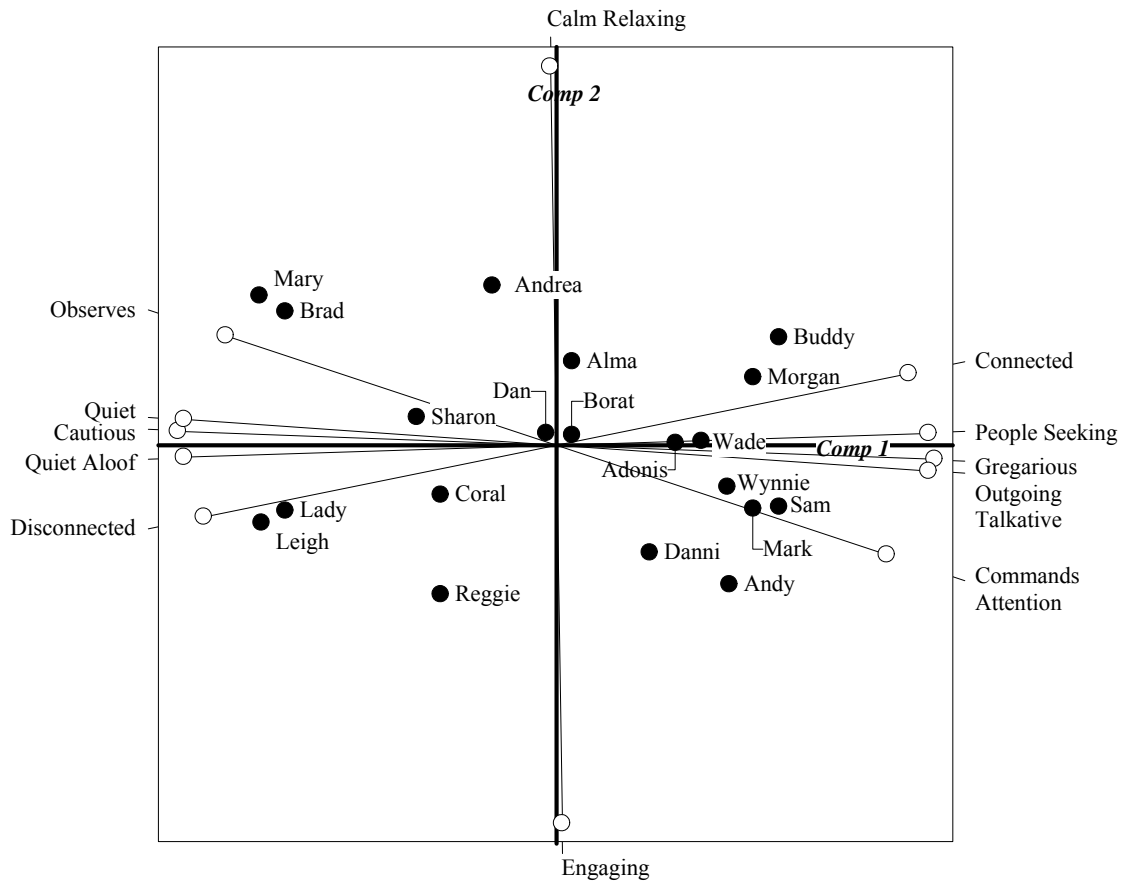

Figure 10. Biplot for Sharon and Dan's repertory grid.

Buddy is located towards the Active Social pole of Component 1 and towards the Calm Relaxing pole of Component 2. This may suggest that as well as being seen as actively social, he was also seen as somewhat calm and relaxing. Sharon and Dan are not located close to any dogs. This suggests they may have seen all dogs as different to themselves. Adonis and Buddy are located towards the Active Social pole of Component 1, which contrasts with Lady who is located towards the Reserved Distant pole of Component 1 near Leigh. This may suggest that Dan and Sharon saw Lady and Leigh as similar. They are also located close to the Disconnected construct, which may also suggest that this was an important construct in defining Lady and Leigh.

*Wynn timer**Unrotated Eigenvalues*

Reported in Table 43 are the eigenvalues for each principal component extracted from Wynn timer's grid. Two principal components account for 79.14% of the total variance. This means that 20.86% of the variance is not accounted for by the two principal components. This variance is within acceptable limits for this analysis and can be validated through the scree plot and application of the Kaiser criterion.

Factor Loadings

Reported at Table 44 are the factor loadings for each component. The first component appears to be heavily loaded on Constructs 1 and 2, and to a lesser extent on Construct 3. This suggests that this component may be characterised by spontaneous, boisterous, outgoing and positive emotion. The spontaneity facet of this construct is supported by the heavy negative loading of Construct 4. These factor loadings suggest that the contrasting pole of this construct may be characterised by formal, quiet, gentle, disciplined, practical and traditional. They also suggest that this component may be labelled Spontaneous Extraverted Optimism—Disciplined Reserved Practical.

The second component appears to be heavily loaded on Constructs 5 and 6. This suggests that this component may be characterised by the clarity with which Wynn timer understood people's purpose in attending the course, their motivation or reason for being there, and their tolerance and acceptance of others. Initially these constructs appear to be unrelated, however they share a correlation of $r = 0.70$ ($p = 0.05$). Therefore the second component may be characterised by tolerance, acceptance of others, non-critical and motivated to attend with purpose. These factor loadings suggest

Table 43

Eigenvalues and Component Variance for Wynnie's Grid

Component	Eigenvalue	%Variance	% Cumulative variance	Scree plot
PC_1	3.46	57.70	57.70	*****
PC_2	1.29	21.45	79.14	*****
PC_3	0.75	12.52	91.66	****
PC_4	0.30	5.03	96.69	**
PC_5	0.12	2.07	98.76	*
PC_6	0.07	1.24	100.00	*

that the contrasting pole of this component may be characterised by lacking purpose and critical of others. They also suggest that this component may be labeled Purpose Accepting—Desultory Critical.

Biplot

The biplot reported in Figure 11 presents a graphical picture of Wynnie's construct space. It places both the constructs and elements plotted against the two principal components. The biplot reveals a general tendency towards a dichotomous structure of Wynnie's construct space. It places all elements, except Buddy and Adonis, along a diagonal line from the bottom left to the top right. This may indicate that Wynnie used both components dynamically to create groups of elements either side of the centre that are the inverse of others. This may suggest that the two principal components operated together in a relative manner to define Wynnie's construct space.

Table 44

Factor Loadings for Wynn's Grid

	Construct		Factor loading	
	Emergent pole	Implicit pole	PC 1	PC 2
1. Happy Energetic	Formal Precise		0.86	0.32
2. Outspoken, Out-of-Turn	Disciplined		0.91	0.04
3. Philosophical Metaphysical	Practical		0.62	0.07
4. Intense	Casual		-0.92	-0.23
5. Purpose to be Here	Not Sure Why Here		0.00	0.96
6. Tolerant Patient	Not Accepting Stropy		0.14	0.84

For example, elements construed as low on the Accommodating Motivated component, were also construed as less on the Spontaneous Extraversion component. Conversely elements construed as high on the Accommodating Motivated component, were also construed as high on the Spontaneous Extraversion component. Therefore, the majority of elements fall within either the bottom left or top right quadrants of the biplot. This may suggest a simple construct system, and “black-and-white” method of thinking.

Buddy and Adonis are located in the bottom left quadrant closer to the right hand side of the Spontaneous Extraversion component, and at the same time towards the bottom end of the Accommodating Motivated component. They are separate to all other elements and are the only ones that contradict the overall diagonal dichotomous pattern within the grid. Adonis is the furthest away from any construct. This suggests

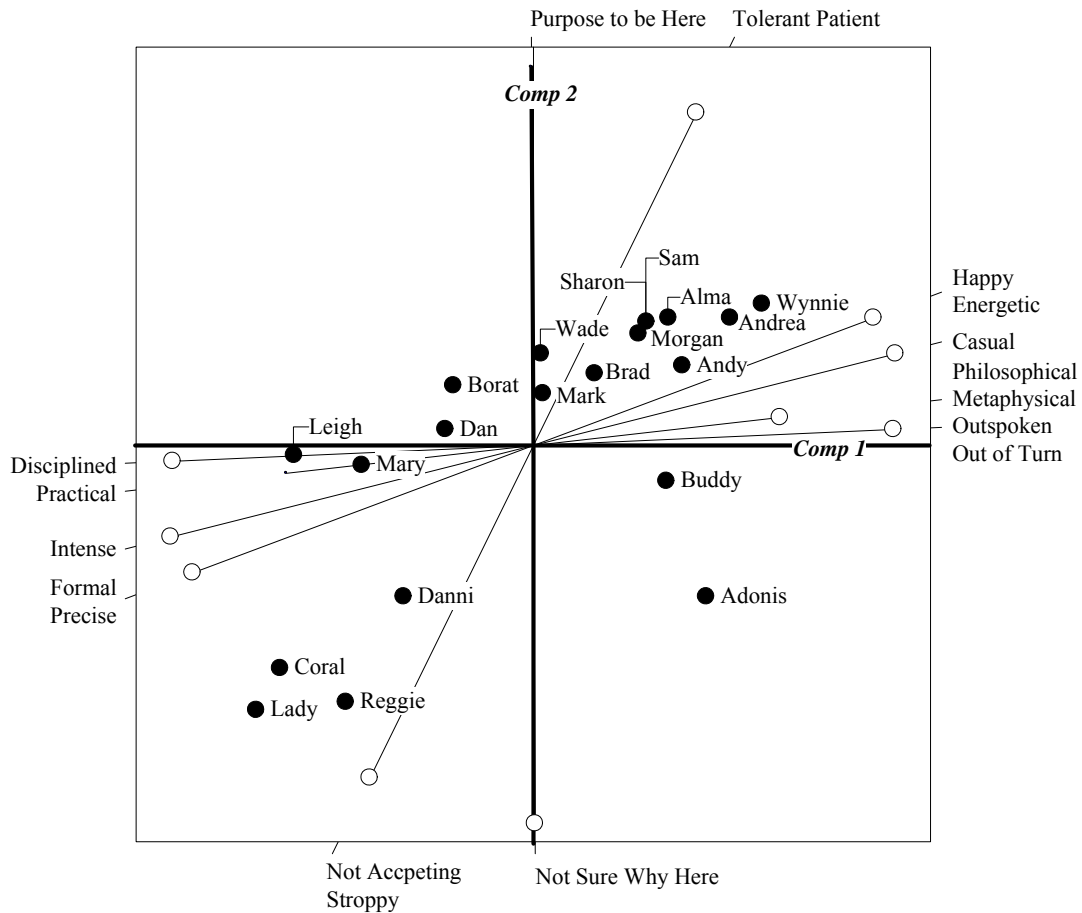

Figure 11. Biplot for Wynnie's repertory grid

that he was uniquely defined within Wynnie's construct space. Five elements, Borat, Brad, Dan, Mark and Wade appear close to the centre of the biplot. This suggests these people may not have been well defined within Wynnie's construct space. One construct, Philosophical Metaphysical—Practical, is located close to the centre of the biplot. This suggests that this construct may have been less important in defining Wynnie's construct space and can therefore be considered to be of less importance to her construct system. No elements appear in the upper left portion of the top left quadrant. This suggests that for Wynnie, no elements could be defined as high on the Accommodating Motivated component and low on the Spontaneous Extraversion component.

The grouping of Coral, Lady and Reggie towards the bottom left of the biplot, suggests that Wynnie may have construed these elements as distinctly separate from others, and as being less accepting, critical and formal without a clear motivated reason for attending the course. Reggie appears close to Not Accepting Stropky and Leigh and Mary close to Practical. This may suggest that Wynnie saw Reggie as the least accepting and most critical member of the group, and Leigh and Mary as the most practical, logical and analytical member of the group. The placement of Leigh and Mary close to the centre of Component 2 may suggest that Wynnie defined them primarily along the Spontaneous Extraversion component, and that Component 1 was less important in defining these people. Wynnie placed herself higher on each of the principal components than any other element. This suggests that she saw herself as the person who was the most accommodating of others and had a clearly defined, motivated purpose to attend the course. Andrea, with whom Wynnie described during the interview as having, “a little bit of a connection more than anyone in the class,” is placed very close to herself on the biplot.

Summary

This chapter presented and explained the results of the data collected through the pre-course questionnaire, critical events technique, classroom observations, post-course discussions and application of the repertory grid technique. These results included: profiles of the participants; patterns of dog behaviour and people’s interaction with them; patterns of elements and distinguishing attributes that characterised the way people interacted with the dogs and the meanings they derived from them.

The patterns of dog behaviour and people’s interaction with them, were distinguished by three aspects: socialisation, active spontaneous behaviour and passive disciplined behaviour. The pattern of elements that distinguished the way people

interacted with the dogs revealed four domains: physical, cognitive, affective and social domains. Dog interaction in the cognitive domain was characterised by elements of: attentiveness, distraction and blindness. The affective domain was characterised by elements of emotion, emotional climate, motivation and empathy. The social domain was characterised by elements of appeal, human agency, enculturation, social axioms, and socialisation. Finally, the analysis of the repertory grid data revealed a consistent set of constructs and components that people used to understand the classroom. These constructs and components suggest that people saw their learning environment largely through a social lens. The biplots revealed a dichotomous structure of several participants' construct space that represented uncomplicated and "black-and-white" thinking. The following chapter will discuss the interpretation of these results and explore answers to the two research questions.

CHAPTER 5: DISCUSSION

Introduction

Chapter 1 introduced to the aims of this research and highlighted two questions that it seeks to answer: In what ways do people use dogs as mediating artifacts in their meaning-making processes; and what are the effects of dogs in mediating individual and group learning processes?

Chapter 2 examined the body of literature surrounding the context within which the research is located and explored the vocational education and training sector in Australia as an example of contemporary models of teaching and learning. This view of adult learning was contrasted with the social constructivist framework that emerged from the Soviet school of sociocultural theory, central to which is the concept of artifacts that mediate human understanding. Finally several ways in which dogs may be seen to function as artifacts in society were examined, to provide a framework on which to scaffold thinking in answering the research questions.

Details of the research methodology were presented in chapter 3, which included a description of the data collection tools and methods used along with methods and techniques used in the analysis of data. Chapter 4 presented the results that built the logical chain of evidence used to develop emergent hypotheses and findings. This chapter will discuss the interpretation of those results and explore answers to the two research questions.

To be able to plausibly answer the first research question, it is first important to establish the premise that the dogs were used. It was pointed out in chapter 2 that Guribye (1999) and Sunder (2002) argue that in order to establish the use of an artifact, an intended goal must first be formulated and then an artifact selected or fashioned and used to help achieve that goal. It has previously been argued that dogs may be seen to

have been fashioned for particular uses through the process of domestication, and their use may also be implied by the outcomes achieved through interacting with them, irrespective of whether those goals are intentional or unintentional (Pearsall, 1999). Therefore, this discussion adopts the somewhat unconventional approach of answering the second research question first to establish the outcomes from people's interactions with the dogs and thus ascertain that the dogs were used. The discussion will then examine the patterns of people's interaction with the dogs from which use can be inferred. Factors of artifact use will also be explored to deepen and enrich this understanding. Finally, implicit in both research questions is a focus on students. However, this discussion will suggest that *people* may also come to encompass the teacher and the researcher, and may thus help develop an understanding of the ways in which they too used the dogs as artifacts.

With a limited base of data, the explanations provided are tentative and await refinement and elaboration in the light of more empirical data. This discussion does not aim to build a theory, but rather it seeks to illustrate through an exemplary analysis of a small but rich body of data, how an analysis of understanding dogs as mediating artifacts might be conducted. It thus aims to provide an analytical framework for understanding the mediating role of dogs in people's learning processes on which to scaffold strong theory building when more extensive data is available.

Mediation: The Effects of Dogs on the Learning Environment

To explore answers to the second research question, "What are the effects of dogs in mediating individual and group learning processes," the discussion will focus on three key findings. First, it will explore how it may be possible to interpret how dogs may have functioned as artifacts in mediating participants' individual cognitive processes by stimulating arousal, attention, focus and concentration through positive

distraction. It will then consider ways it might be understood that the dogs may have functioned as artifacts in mediating emotion by fostering positive emotional responses to arousal, stimulating feelings of enjoyment, calm, warmth, peace, and fostering a relaxed and informal atmosphere that may have factored in the emotional climate in the classroom. The discussion will also explore how it might be conceived that the dogs may have functioned as artifacts in mediating people's social learning processes by: serving as a social ice-breaker and providing a value-free conversation starter. Finally, the discussion will consider how it may be possible to interpret how the dogs may have functioned in people's perceptions of others through the use of social axioms, which may have factored in the construction of their social relationships.

Mediating Cognition

The patterns arising from the analysis of the interview data suggest that the dogs may have functioned as artifacts in mediating people's learning processes by stimulating arousal, attention, focus and concentration that Trzepacz and Baker (1993), Hastings and Bham (2003) and Helmke (1986) suggest are important conditions for learning and student achievement. Arousal was suggested by several students who said that the unexpected barking and behaviour of the dogs, "woke me up," and stimulated their state of responsiveness by creating interest and relief from a previous state of boredom. For example, Morgan described, "When the afternoon dog came, everyone sort of got excited." Yerkes and Dodson (1908) suggest that such arousal may lead to increased performance in learning simple tasks, and that when learning complex tasks there is an optimal level beyond which arousal may reduced performance. Thus, a moderate level of arousal from the dogs may create positive conditions for learning, however too much may have the opposite effect.

The dogs may have functioned as artifacts in mediating people's learning processes by stimulating attention. Trzepacz and Baker (1993) describe attention as the ability to focus and direct cognitive processes while in a physiologically aroused state that, when sustained for a period of time, leads to concentration. This description of attention resonates with several participants who described how short frequent interactions with the dogs provided a reprieve from cognitive fatigue, and likened the effect to a short "brain break" that allowed them return to the learning task feeling refreshed and with greater focus and attention. These findings appear to be consistent with Johnstone and Percival (1976) who point out that short breaks such as those provided by the dogs, may enable the teacher to command greater attention spans from students and eliminate the occurrence of attentional breaks. They also appear to resonate with Middendorf and Kalish (1996) who suggest that when teaching periods are interspersed with short breaks as brief as two to five minutes, students appear re-energised and better able to maintain attention, focus and concentration for the next 15 to 20 minutes.

The implications of the short breaks such as those provided by the dogs are accented by Middendorf and Kalish (1996). They argue that the ability for adults to maintain focus and attention during a standard 75-minute lecture period is limited to between 10 and 18 minutes at the beginning, and declines to between three and four minutes towards the end. However, the variance described by Middendorf and Kalish (1996) and Cashin (1985), appears to suggest that attention spans may differ from person to person. Thus, the short breaks provided by the dogs, which appeared to occur spontaneously at different times for different people often with great frequency, may point towards those breaks occurring at a time that was determined by individual attention spans. Additionally, the dogs may have mediated people's cognitive processes

by providing a continual flow of arousal and attentional reinforcement, rather than when attention was partially or fully depleted. Thus, the continual flow of arousal and attentional reinforcement provided by the dogs may be viewed as precautionary, and may have equalised the peaks and troughs in attention levels implied by the structured use of breaks in the manner suggested by Johnstone and Percival (1976).

The description by some students of the dogs as, “like desk toys that you get at conferences,” and as, “an aide...towards the course,” suggest that the dogs may also have stimulated attention, focus and concentration by providing a point of visual focus and aiding students’ ability to attend to incoming information. This resonates with the findings of Andrade (2010), whose study on doodling suggests that engagement in a secondary task can: aid concentration on a primary learning task; facilitate better recall by encouraging deeper processing of incoming information; reduce competition on cognitive resources from undesirable stimuli and thus reduce instances of daydreaming.

Smallwood and Schooler (2006) argue that daydreaming is a common response to student boredom. Student boredom was evidenced by people’s descriptions of the task environment that are reported at Appendix L, and their observed behaviours that are reported at Appendix K. However, several people described how the dogs helped reduce instances of daydreaming by drawing attention to them and maintaining focus within the room. For example, Andy explained that, “He [Adonis] took all the attention away from everything...the attention was on him...You didn’t see anybody sitting here all day looking out the window...they were watching what the dog was doing.” This suggests that the dogs may have helped reduce competition on cognitive resources from undesirable stimuli, and this appears to be supported by a number of students who explained that the dogs helped re-engage people who were already distracted by other factors. For example, Danni said the dogs, “brought him [Andy] back into it [the

lesson].” Similarly, Morgan said that, “Danni was beside me and she was on the internet doing something, and the dog ran under the table, and she stopped doing that, and got distracted for the second time by the dog.”

These findings resonate with those of Nicholls (2006) who reported that the interactions between her Year 7 students and her dog were characterised by the dog stopping and engaging with students who were gazing out the window, and drawing them back to the present by initiating interaction with them. Further evidence that the dogs may have aided in reducing daydreaming was suggested by students who described how the dogs provided people with, “something to look at, so the dog was entertainment,” and with a, “nice distraction when people had nothing to do.”

The notion that the dogs may have mediated people’s learning processes by stimulating arousal, attention, focus, and concentration, appears to resonate with the teacher’s perceptions. For example, Sam explained that through frequent and short interactions with the dogs, people’s concentration appeared to be extended over a longer period compared to similar classes. For Sam, this was evidenced by students who wanted to continue working during the lunch period and even after class. However, these perceptions appear inconsistent with the observational data reported in Appendix K, which revealed that students frequently requested early breaks and asked to leave early, were absent during the lunch period, and packed up and left promptly at the end of the class. This inconsistency may point towards incongruence between the teacher’s perceptions and her students’ learning processes that could possibly contribute to a divide between them. Conversely, it may also indicate a potential bias arising from the teacher saying what she believed the researcher wanted to hear.

It appears from this discussion that the dogs may have mediated people’s cognitive processes by stimulating arousal, attention, focus and concentration by being

anchored in the present and being imbued with a sense of now and the moment. Further, it appears that this mediation occurred through one source, the dogs, rather than through two or more sources of stimulation. It also appears that this mediation occurred at times and in ways that were individually determined to be most relevant and meaningful. It appears ironic that dogs, in mediating cognition, appeared to do so through what participants described as, “positive distraction.”

Several students stated in the initial questionnaire that they expected the dogs to be a distraction in the classroom. This preconception was shared with the researcher by several students, practitioners and colleagues, during the course of this study. Yet there was a lack of consensus amongst participants as to whether or not the dogs were a distraction. Nevertheless, students emphasised that the distraction from the dogs was, “positive,” “nice,” and, “pleasant.” The notion of dogs as a form of positive distraction was typified by Sharon’s comments that:

I found when it got a bit boring it was a good distraction to see what they were doing. I thought at first, when I heard about the idea of you having dogs in the class I thought, it’s going to be distracting. But in fact it was more of a positive distraction.

Implicit within traditional understandings of distraction is the negative concept derived from its meaning as an obstacle or diversion from attention (Thompson, 1995). Similarly, established views of distraction frequently place the teacher in competition with mobile phones, side conversations and technology in an attempt to gain their students’ undivided attention, as suggested by Barbazette (2006), Cummings (2003), Mortkowitz (2010) and Popp (2005). This gives rise to the irony in this study where distraction, which is traditionally viewed as a negative construct, was seen as positive when roused by interaction with the dogs.

Yet distraction as a positive concept is most often thought of in situations where the stimulus is undesirable. For example, Le Page (2010) reports that in cognitive behavioural therapy distraction is used by people experiencing depression and eating disorders to relieve anxiety and pain. Similarly, Shepley (2006) suggests that access to positive distraction, the most prominent of which are art, music, entertainment, humour and nature, may be a factor in reducing patient stress by allowing the individual to shift attention from negative foci.

However, this study suggests that the distraction caused by the dogs may have had a positive effect on students' learning processes by stimulating arousal, attention, focus and concentration. These results are consistent with Higgins and Turnure (1984), Ruff and Capozzoli (2003), and Turnure (1970) who suggest that on some occasions distraction may impede learning performance, and on others it may enhance performance. Additionally, Foulger (1977) reports that where distraction is enjoyable, the transfer of positive feelings from distraction to what is being conveyed by the teacher may serve as a positive reinforcement that can aid in students' acceptance of the message.

The results of this study appear consistent with others such as Miller et al. (2003), Heimlich (2001), Nathanson (1998), Netting, Wilson and New (1987) and Fawcett and Gullone (2001) who suggest that in therapy and childhood education settings, dogs may aid in improving concentration and attention spans, increasing short and long term memory and improving knowledge of concepts. However, the results of this study may extend this thinking by understanding how factors may contribute to these results. They may also provide the new understanding that this phenomenon may not be limited to therapeutic and childhood education environments, but may also occur amongst adults in workplace vocation education and training settings.

When distraction is viewed as a positive construct, the results of this study suggest a critical examination of established concepts of on-task and off-task behaviour in the classroom. Randolph (2007) suggests that off-task behaviour refers to all activities in the classroom where students have inappropriate interaction with others or attend to stimuli other than instruction. Off-task behaviour contrasts with on-task behaviour, which Thuen and Bru (2000) describe as those activities in the classroom where students pay attention during instruction or concentrate on individual or group work tasks. Doyle (2006), Emmer and Stough (2001), Helmke (1986), and Roberts (2010) argue that established thinking has mostly focused on the positive value of on-task behaviour and has treated off-task behaviour as undesirable with negative consequences.

However, the results of this study suggest that on-task and off-task behaviours may be more difficult to observe and define than has been traditionally thought. For example, some behaviour may readily be identified as undesirable such as playing solitaire or leaving the room. On the other hand, behaviour such as patting or playing with the dogs may ostensibly seem to the teacher to be off-task as the student may appear to be attending to stimuli other than instruction. Conversely, this behaviour may be functioning covertly on an individual's cognitive processes, and thus may be viewed as on-task. In a similar way, what may ostensibly seem to the teacher to be on-task behaviour, such as the use of computers, may in fact be undesirable. For example, the analyses of participants' descriptions of the task environment that are reported at Appendix L suggest that students chose to deliberately distract themselves from the learning task by using the computers to look up web sites, check email and play games.

Finally, implicit within the discussion of on-task and off-task behaviour is a binary that suggests students are engaged in either on-task or off-task behaviour, but not

in both at the same time. Such a view however, may appear to be an oversimplification, as students seem capable of engaging in more than one task at a time, such as doodling or observing and patting a dog, whilst still actively engaged in a learning task.

Mediating Emotion

The analyses of participants' descriptions of the affective and social domains reported at Appendix L, suggest that for most people, the emotional climate in the classroom was characterised principally by annoyance, anxiety, disappointment, frustration, sufferance and unhappiness arising from elements of the task environment. This notion is accented by the observation that of the 60 comments made by students to describe the emotional climate, 53 were negative; only seven comments described the emotional climate as friendly, comfortable, happy or supportive. These results support the suggestion that most students experienced the emotional climate as negative and unpleasurable.

However, against a background of a negative and unpleasurable emotional climate, the data analysis suggests that the dogs may have functioned as artifacts in mediating people's learning processes by: triggering positive emotional responses to arousal; stimulating feelings of enjoyment, calm, warmth and peace; and by fostering a relaxed and informal atmosphere that may have factored in the emotional climate in the classroom. For example, it was discussed previously that students described how the dogs stimulated arousal, which according to Mandler (1984), is a key element in triggering students' emotional responses. Some students described initial arousal from the dogs as surprise, fright and shock, yet for many it was accompanied by feelings of fun, excitement, humour and amusement. For example, Borat said that, "people generally just had a fun," Similarly, Wynnie said that Adonis was, "running around sniffing crutches...and it was just funny." Dan and Sharon explained that the

unexpected behaviour of the dogs created, “excitement for the minute,” and Danni explained that Sharon, “lit up,” when approached by Adonis. The positive emotional responses triggered by arousal were also reflected by people who smiled when they watched the dogs, and laughed at their behaviour.

A number of other students also recalled feeling afraid, unnerved, upset, worried, anxious and stressed that they explained arose from their unfamiliarity with and uncertainty of the dogs’ behaviour, and concern that one dog had shown what they perceived as aggression towards Reggie. However they further explained that these negative emotional responses were short-lived, and were quickly followed by a positive emotional residue that arose from the dogs’ unpredictable, mischievous, spontaneous and neotonistic behaviour. This positive emotional residue was characterised by similar feelings of fun, excitement, humour and amusement that were described by other students.

Additionally, many participants explained that their interactions with the dogs stimulated feelings of enjoyment, fun, pleasure and informality by, “break[ing] up the vibe,” and by, “bring[ing] normality into the training room,” which they likened to opening a window and being part of the outside world. The way these feelings may have factored in people’s learning processes was epitomised by Leigh who said that in an informal environment she felt able to talk more freely, and learned more when comfortable with her surroundings.

The data analysis further suggests that people’s interaction with the dogs may also have moderated feelings of stress and anxiety. For example, several students described how they found interacting with the dogs to be relaxing, peaceful and calming, and that the dogs made people, “feel more comfortable and at ease.” However, only two participants, Danni and Sam, described the moderating effects of the dogs on

their own feelings of stress and anxiety. For example, Danni explained that on the last day of the course:

We were the three that were probably of all of us, were a bit more tense...and that dog seemed to calm us down... people seemed to draw on that dog today that they didn't yesterday, and it was during a period where the room was tense.

This resonates with Sam who described how for her, the dogs, “really made me calm down...settles my nerves, relaxes me.” In contrast, other students described the moderating effects of the dog through generalised supposition. This was illustrated by Morgan's comments that, “some people, they may find it relaxing,” for which limited supporting evidence was offered. These results may support the view that the dogs mediated people's feelings of stress and anxiety. Conversely, they may also point towards potential bias arising from people saying what they believed the researcher wanted to hear.

In summary, this study suggests that people's interaction with the dogs may have mediated their emotions and the emotional climate in the classroom by moderating the unpleasurable aspects derived from elements in the task environment. Many people said that their interactions with the dogs appeared to moderate stress, anxiety and tension, and helped create feelings of enjoyment, fun, pleasure warmth and informality. However these results were not universal. This implies that the results of this study could be limited by the way people interacted with the dogs or by the time restriction imposed by the duration of the course.

Nevertheless, the results of this research appear to resonate with the findings of similar studies. For example, Fawcett and Gullone (2001), Townsend (2003), Katcher and Wilkins (1994), Katcher et al.(1983), Burgess (1997), Rossbach and Wilson (1992), Messent (1983), Serpell (1990) Soares (2003), Nicholls (2006), Anderson, Reid and

Jennings (1992) and Crowley-Robinson et al. (1996) suggest that dogs in childhood education and therapeutic settings may contribute to the creation of a positive climate that is pleasurable, less anxious or stressful, and one that is not subject to feelings of rejection. They also suggest that dogs enhance positive mood, reduce tension and lower levels of physiological response to stressors. Yet the results of this study may provide the new understanding that this phenomenon may not be limited to therapeutic and childhood education environments, but may also occur amongst adults in workplace vocation education and training settings.

The importance of these findings for practitioners is emphasised by several writers such as Le Doux (1996), who have attempted to show the connection between cognition and emotion. For example, Pert (1997) argues that emotions are critical to learning, have a powerful influence on people's cognitive processes, and shape how learning is stored in memory. Similarly, Bower (1981) concludes that emotions are part of the structure of memory, and argues that the efficacy of memory can be influenced by emotion and mood, and may lead to improved retention and recall. Additionally, Foulger (1977) suggests that one of the reasons for this may be that the positive feelings such as those roused from interacting with the dogs may serve as a positive reinforcement that can aid in students' acceptance of the content of learning. In contrast, Sieber and Tobias (1997), Spielberg (1966) and Sapolsky (1999) suggest that anxiety may impair performance in a wide range of cognitive functions including attention, concept formation and problem solving, and may have negative effects on memory and learning.

Mediating Socialisation

The patterns arising from the analysis of interview data suggest that the dogs may have functioned as artifacts in mediating people's social learning processes by:

serving as a social ice-breaker and providing a value-free conversation starter and, “something to talk about” that Tuckman (1965) suggests, characterises the first stage of effective group functioning. These patterns also suggest that the dogs may have functioned in people’s perceptions of others through the use of social axioms, which may have factored in the construction of their social relationships.

Tuckman (1965) and Tuckman and Jensen (1977) suggest that all small training groups progress through a number of distinct phases as they strive to realise their performance potential. These phases are forming, storming, norming, performing and mourning. During the first phase of group functioning people avoid conflict, orient themselves to the task at hand, and attempt to understand boundaries as they get to know each other. The second stage is characterised by competition and conflict that is followed by the third stage where the group develops cohesion by sharing feelings and ideas and developing a sense of belonging. During the fourth stage group morale is high as it realises its performance potential and becomes highly task and people oriented. The final stage is characterised by recognition for participation and achievement, and saying goodbye. Tuckman (1965) points out that the teacher’s role is to help students interact with one another in a productive and less defensive manner by facilitating their progress through each phase. This ensures that the group does not get stuck in any one phase, which may hamper both the ability of the group and individuals to function and perform effectively.

The description of the dogs by several students as an, “ice breaker,” that gave people, “something non-controversial to talk about,” appears to suggest that the dogs may have factored in people’s experience of Tuckman’s first phase of group functioning. This is supported by the observational data where on a number of occasions, people were seen approaching and greeting the dogs when they arrived and

during the breaks, engaging in social conversation with others about the dogs, and sharing their personal experiences with dogs in other settings. In these ways, the dogs may be seen to have fostered elements of group forming during which, as Tuckman (1965) suggests, people were orienting themselves towards each other, were looking to avoid conflict, and were looking to rely on safe, patterned behaviour. The notion that the dogs may have fostered elements of group forming also appears to resonate with the descriptions by Levinson (1969), Fawcett and Gullone (2001) and Saunders and Robins (1991), of dogs as social catalysts and facilitators who establish trust and stimulate safe conversation.

However, the analysis of participants' descriptions of the social domains that are reported at Appendix L, suggests a generalised absence of Tuckman's other phases of group functioning. This may point towards a generalised lack of socialisation amongst participants. For example, storming, which is characterised by conflict, was evidenced on only three occasions: twice on the first day of the course when Coral challenged the teacher, and on the last day when Danni voiced her concerns about watching a video. Most noticeably, there was limited evidence to suggest that the group progressed through Tuckman's norming, performing or mourning phases.

The absence of evidence to support effective group functioning also appears to be reflected in the social dynamics that operated in the classroom. For example, the analysis of participants' descriptions of the social domains reported at Appendix L, suggests that the social dynamics may have been moderated by elements of the task environment such as the power and control hierarchies, what may be interpreted as elements of oppression, and the possible imbalance between assessable outcomes and people's learning processes.

The dynamics of people's social relationships was acutely reflected in the number of people who, after spending approximately 50 hours together, were unable to recall the names of other students. This was vividly captured in Brad's comment that, "to me those fellows there could have been on the moon." These dynamics are also evidenced through the repertory grid data. For example, reported at Table 45 are the principal components that appear to describe aspects of socialisation. This suggests that for many people, the classroom was construed largely through a social lens. This social view of the learning environment seems to contrast with what appeared to be the teachers' focus on the task domain.

The biplots derived from the principal component analysis of each person's repertory grid suggest that people seem to have understood themselves in similar ways to the people whom they were seated next to or near, and in different ways to people who were seated further away. This suggests the formation of social factions. This was further evidenced by Sharon and Dan who described two main groups in the room as, "that side and our side," each of which they explained was constructed of smaller groups of two and three people. Similarly, several students explained that not at any time did they converse with students seated further away, and that they only interacted with those people whom they were seated near. Similarly, Sam explained that students, "weren't in a group...they were very isolated." This resonates with Coral's description that she felt people were confined in, "like a little universe...your own corral." The formation of social factions was further suggested by people's biplots that depicted Coral, Reggie and Lady as outliers and socially separate from others who were seen as the most unapproachable, untrustworthy, formal, disciplined, aloof, critical, guarded, cold and alone of all participants.

Table 45

Principal Components Describing Socialisation

Emergent pole	Implicit pole
Trustworthy Approachable Accepting Participative Motivated	Wary Holds Back Aloof Vulnerable
Active Excited Passionate	Quiet Settled Distant Removed
Open Warm Easy Going	Serious Guarded Cold Loner
Spontaneous Flexible Unstructured	Disciplined Structured
Outgoing Sociable Approachable Trustworthy Open	Reserved Unapproachable Difficult to Get to Know Isolated
Loyal Obligated Responsible Towards Others	Complicated Independent Free Agent
Outspoken Social Enthusiastic	Tactful Evaluator Unenthusiastic
Friendly Amusing	Stranger Reserved
Outgoing External Reward Opinion Driven	Reserved Internal Rewards Values Driven
Approachable Attractive	Unapproachable Not Social.
Active Social Outgoing	Reserved Distant Quiet
Calm Relaxing	Stimulated

Emergent pole	Implicit pole
Spontaneous Energetic Casual	Disciplined Formal Intense
Purpose Accepting	Desultory Critical

The biplots of each student except Leigh, revealed a distinct pattern of dichotomous construction of their social view of the learning environment. This was evidenced by people and the dogs appearing along a diagonal or horizontal line across the biplot. This may indicate a simple construct system and “black-and-white” thinking that may further point towards an absence of established processes and effective group functioning. This is further supported by Leigh’s biplot that shows a clustering of people and dogs around the centre, which suggests a lack of clarity and definition of her construct space.

In the absence of established processes, the social dynamics and group functioning appear to have been characterised by people’s perceptions of others that seem to have been factored upon by their use of the dogs in social axioms. For example, several students said that they evaluated the congruence of others’ orientation towards dogs, and their interactions with them, against their own axiomatic beliefs. They explained that this helped them to establish the perceived trustworthiness, approachability and sociability of others. These constructs were also used to describe the principal components derived from the repertory grid data that were previously reported at Table 45. The three axiomatic beliefs that emerged from the data analysis were: people who like dogs are good people and people who do not like dogs are not good people; people who like dogs care about other people and people who do not like

dogs cannot care about others; and people who like dogs are comfortable having them there and people who do not like dogs are not comfortable having them there.

It is important to point out that in epistemology, axioms are self-evident or universally recognised truths; principles that are accepted as true without proof (Pickett, 2006). Therefore, the social axioms used by participants do not represent objective truths. Instead, they represent people's fundamental beliefs that they hold to be true, despite the absence of supporting evidence. Implicit within each of these axiomatic beliefs, is a binary that precludes alternative logical conclusions. This "black-and-white" thinking seems to resonate with the simple construct system and dichotomous construing that characterised people's biplots, and may further point towards an absence of established processes and effective group functioning.

The way these axiomatic beliefs may have factored in people's perceptions of others and the construction of their social relationships was acutely evidenced by Borat, who explained that because he believed Morgan did not like dogs, he believed that she did not care about other people. It was also evidenced by several students who described how they believed dogs can discriminate between good and bad people. These students explained that good people were seen as socially attractive, approachable, trustworthy, and with whom they would like to associate privately. This was contrasted with bad people who were seen as socially unattractive, unapproachable, untrustworthy, difficult to get to know, guarded, cold, aloof, and with whom they would not like to associate privately. Students also explained that they believed dogs are more likely to approach and appear well-behaved near good people and would avoid and behave aggressively near bad people.

The way people's perceptions of others' orientation towards, and interaction with the dogs factored in their perceived trustworthiness, approachability and

sociability was exemplified by Andy who described, “those toffy nosed sheilas,” whom he believed did not want to interact with the dogs. He explained that he saw them as people who cared primarily for themselves rather than others and, “not the sort of people I would associate with.” Similarly he described Alma, whom he believed was averse to the dogs, as someone who was untrustworthy, unsociable and, “only got time for herself and no one else.” In the same way, several people described how they perceived Reggie, who was seen as someone who did not like dogs, to be aloof, cold, unapproachable and untrustworthy. This may have factored in Reggie’s social isolation that was suggested by the biplots. The way these axiomatic beliefs operated on people’s perceptions of others was keenly expressed by Dan who explained, “How people relate to dogs tells me something about the person...bad people are stupid and dogs can smell that.” However, rather than suggesting dogs have the olfactory acuity to detect a person’s intelligence, Dan explained that his belief was developed through experiences with people he saw as unable to develop a positive relationship with dogs, and who appeared to him to be, “not particularly nice.”

Though the evidence suggests that these axiomatic beliefs may have operated on people’s perceptions of others, it is not known whether they were used in a primary manner to establish perception, or in a secondary manner to validate perceptions derived from other means. Regardless, it appears that people’s use of these axiomatic beliefs was based on what they saw or believed to be true, which may have been moderated by factors of perception. These factors could account for incongruities with the observational data. For example, in contrast to what people reported seeing, Alma’s, Coral’s and Reggie’s interaction with the dogs may have gone unseen by others, which may account for the inconsistency with what people reported seeing. Additionally, several students explained that the physical layout of the room and the use of computers

created visual obstacles that made it difficult for them to see other people and their interaction with the dogs.

Further evidence of these incongruities was suggested by Andy who explained that Mark, “had bit of time, but ...it was just, he’d [Adonis] come through between the chairs and he’d pat him, and that was it...he didn’t have a real lot of time for him.” This contrasts with the observations of Mark engaging in play with Adonis, sometimes for extended periods, offering his hand to bite, attracting him by crackling a water bottle, and vigorously rubbing Adonis as he sat on the couch. Similarly, these incongruities suggest that people may not have seen Coral interact with the dogs. This may have operated on people’s perception of her as aloof, cold, unapproachable and untrustworthy, and may have factored in her social isolation that was suggested by the biplots. A further incongruity arose between people who were seen by others as not liking dogs, and how those people self-rated their orientation towards dogs on the pre-course questionnaire. For example, Coral, Leigh, Mark, Mary and Reggie who were seen by others as not liking dogs, all rated a minimum of 4 (*like dogs*) except Coral who rated 5 (*dogs are an essential part of life*).

These incongruities appear to suggest that people’s use of the dogs through social axioms as a factor in the perceived trustworthiness, approachability and sociability of others, may be founded not on what exists externally true in others, but on how people understand others’ orientation towards dogs, and what they see of their interaction with them. Put simply, to establish trustworthiness, approachability and sociability it may be insufficient merely to like dogs. One must also benefit from being seen within people’s field of view to interact with dogs in a manner that suggests a positive orientation.

These results resonate with studies reported by Lockwood (1983) and Griffin (2003), and Sanders and Robins (1991), who suggest that people with dogs are perceived as more friendly, less threatening, more approachable, happier, and more relaxed. They also appear congruent with Hart, Hart and Bergin (1987) and Lockwood (1983) who point out that the presence of dogs may increase people's perceived social attractiveness. Additionally, these results resonate with Ascione (1992), Bryant (1985), Johnson (2001), McIntosh (2001) Paul (2000) and Poresky (1996) and others who suggest that a positive disposition towards dogs is a good predictor of a positive disposition towards other people, and that people who are seen to care for dogs are also seen to care more for other people than those who do not.

The congruence of these results with other studies may suggest that there is an element of truth to the way that the dogs may have factored in the construction of people's relationships through their use in social axioms. However, these results also highlight the important distinction between what exists externally true in others, and how people understand others' orientation towards dogs and what they see of their interaction with them. This notion resonates with Kusuma-Powell and Powell (2005) who suggest that because much learning occurs unconsciously, perception may be more important than objective logic and that students will trust what they perceive and see of others' behaviour more than what is said verbally. In other words, actions really do speak louder than words.

The results of this study also highlight how a teacher who is focused on assessable outcomes and the task environment may view their students' world through that same lens. However, the students in this study constructed their learning environment through a social lens founded not on what exists externally true in others, but through what they understood and held to be true, and what they saw within their

field of view. This may point towards a divide between the teacher's view of the world, and the way her students constructed their learning environment.

Artifact Use: The Ways in Which People Use Dogs as Mediating Artifacts

This section of the discussion will explore answers to the first research question, "In what ways do people use dogs as mediating artifacts in their meaning-making processes?" It will examine four dichotomous dimensions of people's use of the dogs as mediating artifacts: Active—reFlective (A—F), Initiating—Responding (I—R). It will also explore the functioning of individual preferences within these dimensions, which may have been moderated by a number of factors. The notion will also be posited that the dimensions of artifact use, and the dynamics between them, may also share possible relationships with dimensions of personality and individual learning styles.

The Nature of Interactions

The analysis of observational data suggests that the use of dogs as artifacts was dominantly characterised by frequent, short interactions during periods when the dogs were active. These periods seldom exceeded a few minutes and on many occasions lasted for only a few seconds. These short, frequent interactions included talking to the dogs, patting as the dogs wandered past participants or when participants walked past the dogs, as well as briefly looking at the dogs and smiling or laughing. These characteristics were reflected in the interview data by several participants who described the relief from concentration that came from the frequent, short interactions with the dogs, which they found energising and allowed them to refocus.

In contrast to the frequent, short bursts of interaction, there were only five occasions when participants interacted with the dogs for periods of several minutes. These occasions were initiated by the participants and included when Andy played with Adonis for ten minutes whilst Sam used his computer, when Andy fed Adonis several

mints over a 30-minute period, when Mark played with Adonis on two occasions for five minutes, and on the last day when Andrea patted Buddy as she spoke with his handler. The frequent, short bursts of interaction during the lessons contrast with the extended periods of engagement during the breaks when people approached the dogs to greet them, pat them, talk to them, talk about them with their handler, and engage in social conversation about their own dogs. One factor that may explain this behaviour was the emergence of informal or unspoken rules, which is explored in more detail later in this chapter. For example, several students spoke about, “slack off time,” and breaks as the most appropriate time to interact with the dogs because it was not, “work time.”

People’s interaction with the dogs when they were active, contrasts with the few occasions on which participants interacted with the dogs when they were inactive. For example, on one occasion, Sam walked over to Lady who at the time was lying down, and patted and spoke with her. On another occasion, Danni coaxed Buddy who was sitting on the sofa next to his handler. An analysis of the data revealed that Lady, who was the least active of the three dogs, went largely unnoticed by participants. Students appeared to make limited effort to initiate interaction with her or respond when she wandered around the room or near them. This was evidenced by the few occasions when students interacted with or observed Lady, which contrasted with the frequency with which Sam walked over to Lady and patted, hugged and spoke to her.

The analysis suggests that many people’s interactions with the dogs were subtle and covert such as watching, and patting when they were near, which often went unnoticed by others. For example, Andy explained that he did not often see Mark interact with the dogs. Similarly, rather than seeing Leigh and Mary interact with the dogs, Andy saw them as pushing the dogs away.

Nevertheless, the pattern of people's interactions with the dogs that imply their use may be understood by exploring the dimensions of artifact use and factors that may have moderated individual preferences.

Dimensions of Artifact Use

The patterns of people's interactions with the dogs that arose from the analysis of observational and interview data appear to suggest four dichotomous dimensions of artifact use: Active—reFlective (A—F), Initiating—Responding (I—R), Material—Conceptual (M—C) and Spontaneous—Planned (S—P).

Active—reFlective (A—F)

The Active (A) dimension was suggested by people's outgoing, gregarious and enthusiastic interaction with the dogs, and the way they displayed a sense of external energy by patting, hugging, playing, feeding and coaxing the dogs. Patterns of interaction in the Active (A) dimension included: Andy getting out of his chair and playing with Adonis for ten minutes whilst Sam used his computer; Andy feeding Adonis several mints over a 30-minute period; Mark playing with Adonis for five minutes by offering his hand to bite; Mark getting out of his chair, sitting on the couch next to Adonis, and vigorously rubbing him and speaking to him; and Danni calling Buddy's name and clicking her fingers to attract him towards her.

In contrast, the reFlective (F) dimension was suggested by people's contained, personal and quiet interaction with the dogs, and the way they displayed a sense of internal energy by: quietly sitting and watching the dogs as they wandered around the room or were near them, often smiling or laughing as they did so; sitting in their chair and patting the dogs as they walked past; talking about the dogs with other people; stepping over the dogs; and incorporating the dogs into their presentations. Patterns of interaction in the reFlective (F) domain included: Wynnie containing her laughter at

Adonis when he wandered under the tables; students quietly smiling as they watched Adonis; Reggie and Sam stepping over Adonis as they walked around the room; students speaking privately with others during the breaks about the dogs; Sam reaching down and hugging Adonis and Lady; and both students and the teacher using the dogs through which to voice or convey their thoughts and concerns. The third letter of *reflective* is capitalised to avoid confusion with the next dimension, Initiating—Responding (I—R).

Initiating—Responding (I—R)

The Initiating (I) dimension was suggested by people instigating interaction with the dogs, often by attracting the dogs towards them, starting interactions with others by talking about the dogs, commencing play by offering the dogs their hand or other objects to play with, and by offering food to the dogs. Patterns of interaction in the Initiating (I) dimension included: Andy getting out of his chair and playing with Adonis; Mark crackling a water bottle to which Adonis responded by putting his nose against the bottle as Mark patted him; Mark removing the label from the bottle and offering it to Adonis who played with it; Leigh clicking her fingers as Buddy wandered around, to which Buddy jumped up and put his front paws on the desk; Sam walking up to Adonis and Lady and hugging and patting them; and Wynnie getting out of her chair to retrieve printing and approaching Adonis and patting him.

In contrast, the Responding (R) dimension was suggested by people reacting to the behaviour of the dogs by observing, watching or patting them when they wandered around the room or near them. Patterns of interaction in the Responding (R) dimension included: Andy, Borat, Leigh, Mary, Andrea, Coral, Mark, Sharon and Dan frequently patting Adonis as he wandered past them; Mark playing with Adonis in response to Adonis putting his nose towards Mark and whimpering; students commenting about the

noise made by the wagging of Adonis' tail; and students looking around at Adonis when he barked or whimpered.

Material—Conceptual (M—C)

The Material (M) dimension was suggested by people's concrete, practical and physical interaction with the dogs by playing, patting, coaxing and feeding them. Patterns of interaction in the Material (M) dimension included: Mark rubbing Adonis' coat; Andy and Mark playing with Adonis; students patting the dogs; and Sam hugging Adonis and Lady.

In contrast, the Conceptual (C) dimension was suggested by people's abstract, conceptual and imaginative interaction with the dogs by incorporating representations of them in their presentation or exercises; and speaking about them. A distinguishing feature of the Conceptual (C) dimension appears to be that the idea or representation of the dogs, rather than the dog in its physical form, was used to convey ideas and concepts. Patterns of interaction in the Conceptual (C) dimension included: Sharon incorporating pictures of dogs in her presentation; Mark including a drawing of a dog in an exercise; participants speaking with others during the breaks about the dogs, about their own and others' dogs, and about their therapeutic roles in visiting aged-care and medical facilities; and both students and the teacher using the dogs through which to voice or convey their thoughts and concerns.

Spontaneous—Planned (S—P)

The Spontaneous (S) dimension was suggested by people's casual, spontaneous, emergent, open-ended, unplanned and unstructured interaction with the dogs. Patterns of interaction in the Spontaneous (S) dimension included: Andy and Mark impulsively getting out of their chairs and playing with Adonis; students spontaneously patting Adonis as he wandered around the room; Andrea impulsively turning in her chair to

coax Buddy and pat him; Wynnie getting out of her chair to get a printed document and suddenly approaching Adonis to pat and speak to him; Danni unexpectedly attracting Buddy towards her by clicking her fingers and calling his name; Wynnie spontaneously laughing as Adonis wandered under the tables; and by Andy impulsively feeding Adonis mints.

In contrast, the Planned (P) dimension was suggested by people's structured, disciplined, scheduled and methodical interaction with the dog. Patterns of interaction in the Planned (P) dimension included: people interacting with the dogs during structured breaks and when formally introduced to the dogs by the handler; and Sharon's planned incorporation of the dog in her presentation.

Linking Artifact Use with Personality Theory and Learning Styles

These descriptions of the dimensions of artifact use appear to resonate with dimensions of personality that have been used to understand the different ways in which people learn. This suggests that people's use of the dogs as artifacts may share possible relationships with dimensions of personality and people's learning styles.

Eysenck (1978) and Hashway (1998) suggest that educational psychology has often used theories of personality to help explain and understand how people learn and their learning processes. These theories include those developed by Costa and McCrae (1989), McCrae and John (1992), Cattell (1946); Briggs-Myer (1980); Saville, Holdsworth, Nyfield, Crap and Mabey (1984) and Gough (1957). Two notable contributions to educational psychology have been through the application of Myers-Briggs' theories by Kolb (1984) to his Learning Styles Inventory and Experiential Learning Cycle, and by Honey and Mumford (1982) to their Learning Styles Questionnaire.

Eysenck (1978) and Hashway (1998) argue that learning styles may not only be closely linked with personality, but they may also be personality-based. In support of this, Drummond and Stoddard (1992) found an overlap between learning styles and the Myers-Briggs Type Indicator. Similarly, Furnham (1992) reported that there were correlations with Eysenck's four dimensions of personality and Kolb's Learning Styles Inventory (1984), Honey and Mumford's Learning Questionnaire (1982), and Whetten and Cameron's Cognitive Style Instrument (1984). Additionally, Shadbolt (1978) and Busato, Prins, Elshout and Hamaker (1999) have also shown positive correlations between learning styles and dimensions of personality. It is noted at this point that the only insights offered into the learning styles of participants in this research were the self-claimed ones volunteered by only five students. It is also noted that analyses of different learning styles is a tangentially related issue that is not pursued beyond the possible relationships suggested by dimensions of artifact use and the possible relationship they may share with dimensions of personality.

McCrae and John (1992) suggest that many personality theories identify similar traits and characteristics, which Buckley (1994) points out, have been shown to share positive correlations. These positive correlations point towards five common dimensions of personality often referred to as the Big Five. These dimensions are described as Openness, Conscientiousness, Energy, Agreeableness and Neuroticism (McCrae & John, 1992).

Presented in Table 46 is a comparison of descriptions of the dimensions of artifact use and three of the Big Five dimensions of personality: Openness, Conscientiousness and Energy. In addition, patterns emerged from the interview data that provided a clue to a dimension of artifact use that was absent from the observational data, Emotional—Logical (E—L). This dimension appears congruent with the Big Five's Agreeableness. The congruence shared by the dimensions of artifact use and personality, suggests a possible relationship between the two, and in turn with individual learning styles.

The Emotional (E) dimension was suggested by people's description of their interaction with the dogs as being empathetic, emotional, compassionate,

Table 46

Comparison of Personality Dimensions and Artifact Use

Personality dimension	Description	Comparative dimension of artifact use	Description
Openness	Artistic, curious, imaginative, insightful, original, wide interests	Material—	Concrete, practical, physical
		Conceptual	Abstract, conceptual, imaginative
Conscientiousness	Efficient, organised, planful, reliable, responsible, thorough	Planned—	Structured, disciplined, scheduled, methodical
		Spontaneous	Casual, spontaneous, emergent, open-ended
Agreeableness	Appreciative, forgiving, generous, kind, sympathetic, trusting	Emotional—	Empathetic, accommodating, values-driven
		Logical	Logical, reasonable, critical
Extraversion	Active, assertive,	Active—	Outgoing,

Personality dimension	Description	Comparative dimension of artifact use	Description
	energetic, enthusiastic, outgoing, talkative	reFlective Initiating— Responding	gregarious, energy Quiet, intimate, contained Instigates interaction with others Responds to interaction from others
Neuroticism	Anxious, self-pitying, tense, touchy, unstable, worrying	—	—

accommodating and values-driven. Examples of people's interaction in the Emotional (E) dimension included Wynnie who expressed empathy and compassion for Adonis when she said that his barking was, "not his fault...leave him alone." Wynnie and Danni also expressed empathy and compassion for Adonis when they described their concern for his safety when he wandered under the tables, and for his health that may have been compromised by the introduction of stray dogs into the room. Sam also expressed empathy for Adonis when she described the stray dogs as "stealing his thunder" saying, "How dare they come in a steal his thunder. [He is] our dog, yes that's

our dog, what are those strays doing in here.” Similarly, Leigh expressed empathy and concern by not allowing the dogs near Reggie, who appeared to be uncomfortable with the dogs. People’s use of social axioms, where value-driven beliefs about people and their interaction with them factored in people’s perceptions of others and the construction of social relationships, may also suggest the Emotional (E) dimension.

In contrast, the Logical (L) dimension was suggested by people’s description of their interaction with the dogs as being logical, questioning, critical, tough and reasonable. Examples of people’s interaction in the Logical (L) dimension included Brad who appeared critical when he described barking as unacceptable behaviour that for him indicated that something was wrong. Similarly, Borat and Coral explained that the need to focus on the lesson and assessment tasks, along with the physical layout of the room and visibility, may have been factors in their interaction with the dogs. In the same way, several students described the need for a specific purpose for the dogs to be there, and appeared critical when they said that they did not see any direct observable benefits from the dogs.

The dimensions of artifact use also appear to resonate with the findings of Serpell (2004), who identified two motivational determinants of people’s attitude towards animals that he referred to as Affect and Utility. Affect represents people’s affective or emotional responses to animals, and resonates with Agreeableness and with the Emotional (E) dimension. Utility represents people’s perceptions of the instrumental value of animals, and resonates with Openness and with the Material (M) and Logical (L) dimensions for artifact use.

Similar to Serpell (2004), several other studies have attempted to explain people’s behaviour towards animals through theories of attitude and personality (Broido & Manning, 2002; Kellert & Berry, 1980; Mathhews & Herzog, 1997). However, these

studies have limited their enquiry to specific patterns of attitude and behaviour towards animal welfare. Mathews and Herzog (1997) suggest that one of the reasons for the paucity of research into the relationships between people's interaction with animals and personality may be the lack of current favour for theories of personality trait and type within the scientific community.

Dimensional Dynamics

It appears that the Active—Reflective (A—R) and Initiating—Responding (I—R) dimensions may share similarities. However there also appear to be differences that seem to distinguish between them. For example, Active—Reflective (A—R) appears to describe people's energy when interacting with the dogs, which compares with the stimulation or instigation of interaction that describes the Initiating—Responding (I—R) dimension. These differences suggest that the dimensions of artifact use may share dynamic relationships. For example, an Active Initiating (AI) dynamic was suggested by Andy getting out of his chair and initiating active play with Adonis. Similarly, an Active Responding (AR) dynamic was suggested by Mark responding to Adonis by engaging in active play when Adonis pointed his nose towards him and whimpered. In the same way, a reFlective Initiating (FI) dynamic was suggested by students speaking privately about the dogs with others during the breaks. Equally, a reFlective Responding (FR) dynamic was suggested by students who quietly watched and personally responding to the dogs by patting them as they wandered around the room.

Figure 12 illustrates how these dimensions may be plotted in a two-dimensional space when they are construed as axial constructs. This provides a graphical representation of the dynamic relationships between these dimensions. Similarly, the distinguishing differences between the other dimensions suggest comparable dynamic relationships. For example, a Material Spontaneous (MS) dynamic was suggested by

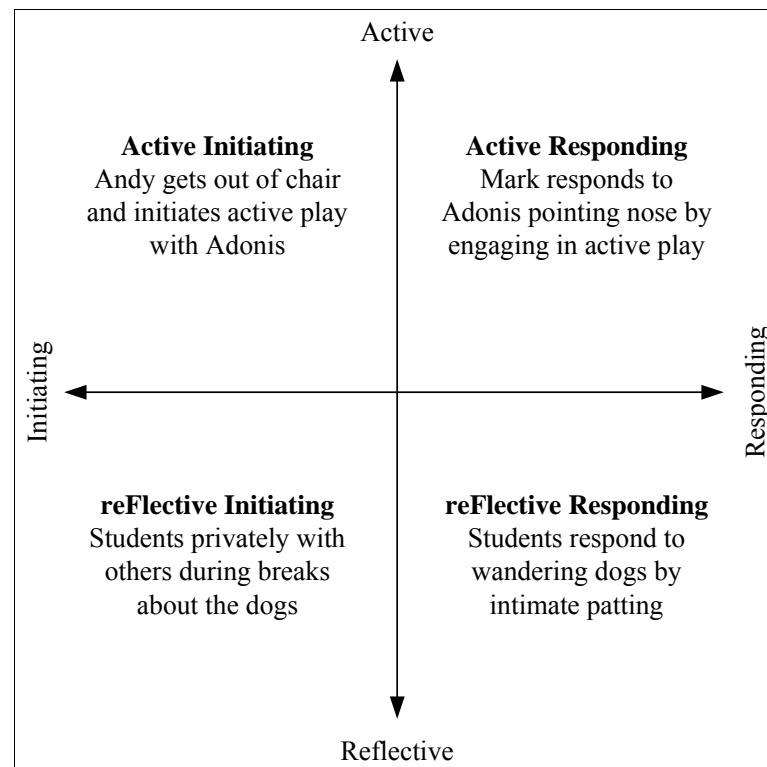

Figure 12. Graphical representation of dimensional dynamics.

Wynn timer who got out of her chair to get a printed document and on impulse, approached Adonis, and physically engaged with him by patting and speaking to him. Similarly, a reFlective Conceptual (FC) dynamic was suggested by Danni who used the dogs through representation to express her limited self-efficacy.

Figure 13 illustrates that a total of six axial grids would be needed to explain all possible dynamic relationships shared between the four dimensions. However, each provides only a two-dimensional view. Six grids also appear cumbersome to use and understand, and insufficient to simply and fully explain the dynamic relationships across all four dimensions. For example, the Material Spontaneous (MS) way Wynn timer interacted with Adonis described earlier, also suggests a personal and contained method of engagement that indicates a further relationship with the reFlective dimension. This relationship could be described as reFlective Material Spontaneous (FMS).

	Initiate	Material	Spontaneous	
Active	1	2	3	Reflective
Initiating		4	5	Responding
Material			6	Conceptual
	Respond	Conceptual	Planned	

Figure 13. Axial grids required to explain dynamics of preference.

Additionally, Wynnie's instigation of the interaction with the Adonis, may suggest a further relationship with the Initiating (I) dimension that could be described as reFlective Initiating Material Spontaneous (FIMS). Similarly, the reFlective Conceptual (FC) way Danni personally and on an impulse, used the dogs through representation as described earlier may suggest a further relationship with the Spontaneous (S) dimension. This relationship could be described as reFlective Conceptual Spontaneous (FCS). Danni's impulsive instigation of the interaction may suggest a further relationship with the Initiating (I) dimension that could be described as reFlective Initiating Conceptual Spontaneous (FICS). Figure 14 illustrates another way to express

		Initiating		Responding	
		Material	Conceptual	Conceptual	Material
reFlective	Planned	<p>FIMP Individually initiating patting at breaks</p>	<p>FICP Talking about at breaks</p>	<p>FRCP Mark's use in drawing exercise</p>	<p>FRMP Quietly keeping dogs from under tables; Individually responding to dogs at breaks</p>
	Spontaneous	<p>FIMS Sam hugs Adonis and Lady; Wynnie pats Adonis when getting printing</p>	<p>FICS Like a refreshing break; voicing through dogs to others</p>	<p>FRCS Voicing through dogs in response to others; laughing at dogs; like a conference toy</p>	<p>FRMS Patting and watching as dogs wander; look at dog when whimpering or making noise</p>
Active	Spontaneous	<p>AIMS Mark and Andy playing with dog; coaxing and feeding</p>	<p>AICS None identified</p>	<p>ARCS None identified</p>	<p>ARMS Mark responding to Adonis through play</p>
	Planned	<p>AIMP Heather taking Buddy to people; engaging with others during the break with dog</p>	<p>AICP Sharon incorporating pictures of dogs in her presentation</p>	<p>ARCP None identified</p>	<p>ARMP Patting and talking to Buddy when introduced; engaging with others during breaks in response to dogs behaviour</p>

Figure 14. Matrix descriptions of dimensional dynamics.

the complex dynamic relationships between the four dimensions. This matrix¹⁵ contrasts each dimension against the remaining three. Presented in this way, all 16 possible relationships, each of which may be described in the form of a four element string, are easily observed and understood through one representation. These dynamic relationships also appear to share congruence with the dynamic relationships between the Big Five dimensions of personality. Therefore, a deeper understanding may arise when each of the dimensions are looked at not separately, but in the context of how they work and interact together, as suggested by Briggs-Myers (1980), McCrae and Costa (1989), McCrae and John (1992), Cattell (1946), Saville, Holdsworth, Nyfield, Cramp and Mabey (1984), and Gough (1957). This resonates with the findings of Serpell (2004) who suggested that his dimensions of Affect and Utility do not operate independently, but rather interact in complex ways that suggest they share a similar dynamic relationship.

Most noticeable by their absence from the data, are three Active Conceptual (AC) dynamics. One explanation for this may lie in understanding what people knew about how to use the dogs as artifacts. This may point towards the opportunity for the teacher to show people how to use the artifact in different ways that are tailored to their individual needs. This notion is supported by the patterns of teacher student behaviours

¹⁵ Similar matrices have been used by Marston (1979), Briggs-Myers (1980) and Keirsley (1978) to explain the dynamic relationships between dimensions of personality, and by Kolb (1984) to explain the relationships between learning styles. They have also been used by Sayers (1978), Hersey, Blanchard and Johnson (1988) and Blake and Mouton (1985) to explain the dynamic relationships between styles of leadership and management.

that are reported at Appendix K, which suggest that students and teachers were not adequately taught how to use other artifacts such as the books, projector and software, effectively. This may also account for the difficulties that the participants experienced in using them. A further explanation may lie in understanding individual preferences within the domains of artifact use, and the factors that bound them.

Preference

Reported at Table 47 are descriptions of comments made by participants that suggest the functioning of individual preferences within the dimensions of artifact use. These descriptions also suggest that the dominant preference was for the reFlective Responding Material Planned (FRMP) use of the artifacts. Reported at Table 48 are constructs that were elicited from the seven repertory grids, which further suggest the functioning of individual preferences. When people described these constructs they implied that for some, one pole was more desirable than the other, as illustrated in the sample detailed analysis of the repertory grid data at Appendix M. These preferences are indicated by the positive and negative symbols appearing next to those constructs.

Reported at Table 49 are six principal components that were extracted from six of the seven repertory grids, which resonate with the Active—reFlective (A—F) dimension. The frequency of constructs and principal components that appear to describe facets of the Active—reFlective (A—F) dimension may suggest that this dimension also operated as key construct in the way people formed their understanding and made sense of the environment within which the dogs functioned as artifacts. The descriptions of these constructs and principal components suggest a dominant preference for the Active (A) dimension. This appears to contradict the interview data

Table 47

Description of Preferences in Each Dimension

Participant	Emergent pole	Implicit pole
Active—reFlective (A—F)		
Borat	Described how he thought he would interact with the dog more than he did.	
Coral		Described how it was interesting to observe dogs.
Mary		Likened desire to interact with the dog with patting a stranger's dog, which she would not be inclined to do.
Mary		Explained that she would probably not have go up out of her chair just to go and pat the dog.
Wynn timer		Described how people did not want to get out of their chair to interact with Buddy.
Initiating—Responding (I—R)		
Borat		I didn't have to approach, he would approach me...that was easier for me. Adonis, you know he just

Participant	Emergent pole	Implicit pole
		comes in, shovels his nose into your arms, you know, or into your palm.
Danni		Every time he [Adonis] came near her [Sharon], she lit up and would respond to him.
Mary		They [students] wanted to pat him if he came near them.
Sam		Lady is not an initiator, Lady will, Lady more responds to somebody else. Lady responds to people.
Material—Conceptual (M—C)		
Borat	Described how having to walk around other people acted like a physical barrier between himself and the dog.	
Coral	Described the physical layout of the room as problematic for the dog to wander freely.	Described the dog as like a conference toy that brought the outside world into the classroom.
Coral	Described how the physical layout of the room created visual obstacles that restricted her vision of the dog.	
Sam		Described the dog as like having a

Participant	Emergent pole	Implicit pole
		cigarette break.
Sam		Described the dog as providing a refreshing break similar to games trainers play.
Several	Described practical concerns for the dog becoming entangled in cords and damaging equipment.	
Several		Use of the dog through social axioms.
	Spontaneous—Planned (S—P)	
Leigh		Described the dog's behaviour as unusual and, "something that you're not used to in a classroom."
Borat	Described Adonis as, "he just comes in, shovels his nose into your arms."	
Brad		"I didn't want to see the joint fall in a heap."
Dan and Sharon	Described the unexpected behaviour of the dog created, "excitement for the minute."	
Leigh		Described Adonis as being

Participant	Emergent pole	Implicit pole
Several	Described the spontaneous barking and wandering behaviour of the dog as expected, natural, spontaneous and acceptable.	undisciplined and, “going where he wasn’t supposed to go... Adonis was more just, you know, rowdy Adonis.” Described Lady and Buddy as being well-trained, well-behaved and disciplined.
Wynnies	“unpredictable... and that’s their natural behaviour.”	Described the appropriate time to interact with the dogs was during the breaks or, “slack off time,” rather than during, “work time.”

Table 48

Constructs Describing Preferences in Each Dimension

Emergent pole	Implicit pole
Active—reFlective (A—F)	
Active +	Quiet -
Excited Naïve	Content Experienced
Committed Passion +	Distant Removed -
Approachable Trustworthy +	Wary -
Happy Participative +	Holds Back -
Down-to-Earth +	Aloof -
Drawn Together +	Separated -
Communicator +	Loner -
Warm +	Cold -
Open +	Guarded Closed -
Outgoing	Reserved
Socialise +	Serious -
Approachable +	Unapproachable -
Open +	Difficult to Get To Know -
Talks To Others +	Isolated -
Amusing	Reserved
Outspoken -	Tactful +
Socialiser	Evaluator
Friendly +	Stranger -

Emergent pole	Implicit pole
Enthusiastic +	Disinterested -
Confident Outgoing	Reserved
Lovable Character +	Unapproachable -
Friendly Lovable +	Spoilt Brat -
Street Wise	Sheltered
External Recognition	Internal Reward
Commands Attention -	Observes +
Connected +	Disconnected -
Gregarious Outgoing	Cautious
People Seeking +	Quiet Aloof -
Talkative -	Quiet +
Emotional—Logical (E—L)	
Easy Going	Serious
Accepting of Others +	Vulnerable -
Socialise +	Serious -
Strong in Principles +	Strong in Opinions -
Tolerant Patient +	Not Accepting Stroppy -
Spontaneous—Planned (S—P)	
Easy Going	Serious
Immature	Mature
Fun Happy-Go-Lucky -	Not Flippant +
Unstructured -	Judgemental +

Emergent pole	Implicit pole
Rowdy	Disciplined
Young Excitable	Mature Settled
Happy Energetic +	Formal Precise -
Outspoken Out-Of-Turn -	Disciplined +
Casual +	Intense -
Not Sure Why Here -	Purpose To Be Here +

that suggested a dominant preference for the reFlective (F) dimension. One explanation for this incongruity may lie in understanding factors that appeared to bind individual preferences.

Factors in the Use of Preferences

During this discussion it has been suggested that the dominant preferences for artifact use suggested by the data were reFlective Responding Material Planned (FRMP), which contrasts with the three Active Conceptual (AC) dynamics that were most noticeable by their absence, and the dominant Active (A) preference that was implied through the construct descriptions derived from the repertory grids. This incongruity appears to suggest individual preferences may have been moderated by a number of factors that paradoxically, may provide further evidence of the functioning of individual preferences.

The notion that a range of factors operated on people's individual preferences resonates with the findings of both Serpell (2004) and Briggs-Myers (1980). For example Serpell (2004), in a study of factors influencing human attitudes to animals and their welfare, suggested that the two determinants of Affect and Utility can only

Table 49

Principal Components Describing Active—Reflective (A—R) Preferences

Emergent pole	Implicit pole
Active Excited Passionate	Quiet Settled Distant Removed
Open Warm Easy Going	Serious Guarded Cold Loner
Outgoing Sociable Approachable	Reserved Unapproachable Difficult to Get
Trustworthy Open	to Know Isolated
Outspoken Social Enthusiastic	Tactful Evaluator Unenthusiastic
Outgoing External Reward Opinion Driven	Reserved Internal Rewards Values Driven
Active Social Outgoing	Reserved Distant Quiet

account for a certain portion of the variance in people's attitude. Serpell (2004) concluded that a range of other factors he called *attitude modifiers* account for changes in people's affective and emotional responses to animals, and their perceptions of their utility. These attitude modifiers include: the specific attributes of the animal; the individual characteristics and experience of the person evaluating the animal; and a range of cultural factors. Similarly, Briggs-Myers (1980) suggests that individual preferences within dimensions of personality are moderated by a range of factors that include culture, family and environment. For example in the business environment, people are often expected to operate within an environment that encourages structure and order to achieve deadlines, comply with policy and procedures, and adhere to legislation that fosters planned, logical, analytical, practical and concrete behaviours (Briggs-Myers, 1980).

Similarly, the data analysis in this study appears to suggest that a range of factors may have moderated individual preferences. These factors appear to share congruence with those identified by Serpell (2004) and Briggs-Myers (1980) and include: the context; the physical environment; ease and effort; what may be interpreted as elements of oppression; rule making; perception; enculturation; and artifact functioning and appeal.

Context

The learning context within which this research study was situated was constituted by the *TAA40104 Certificate IV in Training and Assessment*, which in turn was located within the broader context of the Australian Quality Training Framework that was discussed in chapter 2. Within this context people are often expected to operate in a learning environment that encourages structure and order and that requires compliance with policies, procedures and legislation governing training and assessment outcomes as well as adherence to assessment and competency criteria. The influences of this context were evidenced by people's description of the environmental domains that are reported at Appendix L. These influences include: a focus by the teachers on assessment tasks; the teachers' compliance with standards for teaching and course delivery; the patterns of teacher—student and student—student socialisation; and the incongruity between individual preferred learning styles and teaching technique. Thus, the context within which this study was located may have fostered people's orientation towards introverted, structured, practical and analytical thinking. This may have operated on people's preferences by fostering reFlective (F), Responding (R), Material (M), Logical (L) and Planned (P) patterns of interaction with the dogs.

Physical Environment

Another factor that may have operated on individual preferences may have been the physical layout of the room. For example, several students described the layout as, “very challenging,” and problematic for the dogs to be able to freely wander around. This may have operated on some people’s preferences in the Active (A) and Material (M) dimensions by making it difficult for them to physically interact with the dogs in a manner that was outgoing, gregarious and enthusiastic. Several students also said that the layout created visual obstacles that made it difficult for them to see the dogs. This may have operated on some people’s preference in the reFlective (F) dimension by inhibiting visibility. This appears to be supported by people’s descriptions of the physical environment that are reported at Appendix L. For example, several students described how the layout of the room made it difficult to see others and created a, “shield in front of us,” and likened the isolating effect to, “little invisible cubicles around each one of us.” This was compounded by the isolation students felt from the use of the computers that put people, “into like a little universe, a little corral in the library.” Another aspect of the physical environment described by students was their concern for electrical cords and equipment. This may have been a factor in people’s preferences by focusing concern on Material (M) and Logical (L) factors such as the dogs becoming entangled in cords, or unplugging and damaging equipment.

Ease and Effort

The effort required to get up and purposefully interact with the dogs may have been another factor that operated on individual preferences in the Active—reFlective (A—F), Initiating—Responding (I—R) and Spontaneous—Planned (S—P) dimensions. This was suggested by several students who said that they felt disinclined to get out of

their chair to purposefully interact with the dogs. This was exemplified by Mary's comment that:

I probably wouldn't have gone and made an effort to pat the dog by getting up from my chair to...but I probably wouldn't have got up and then I don't think I ever did, just go and pat the dog, but I did pat it when I walked past if I'd just got myself a drink or something. And I think quite a lot of people probably would do the same.

Ease and effort may also have operated on people's preferences by requiring greater exertion to initiate and actively engage with the dogs, than to interact with them in ways that were responding and reflective. This contrasts with the ease afforded by spontaneously responding to the dogs by watching and observing them or patting them as they wander past. However, the data appears to suggest that the way ease and effort may have operated on people's preference of artifact use, may have had less to do with languor or convenience, and more to do with what may be interpreted as elements of oppression.

Elements of Oppression

Reported at Appendix L is an analysis of participants' descriptions of the social domain that suggests the learning environment was characterised by sufferance, frustration and annoyance. This was suggested by several students who commented that they had to "suffer." For example, Danni said, "we had to suffer for it," and Mary described her release from sufferance by saying, "Thank God it's over." Several students also expressed frustration, annoyance and unhappiness with the structure and presentation of the course and with the behaviour and competence of teachers. These comments suggest that students may have experienced elements of oppression.

Also reported at Appendix L are comments made both the teacher and students that appear to describe characteristics of human agency. These characteristics may provide further indicators of elements of oppression. However, they were not described in ways that distinguished people's capacity to exercise control over how they operated in the world as suggested by Bandura (2001). Rather, they were described in ways that appeared to limit this capacity. These factors of human agency were: dominant voice, where the needs of one person were imposed on the group; fear of retribution from the teachers; acquiescence; roles and hierarchy, where students were seen as subordinate to teachers and felt that they must play within the expectations of a particular character; and normative behaviour through the establishment of unspoken social rules that included patting or playing with the dogs during what was seen as, "work time."

A further indicator of elements of oppression was suggested by the behaviour of students who used the computer to perform personal tasks under the pretence that they were working on lesson-related content. Wynnie described this as, "the old school kid trick." She explained that students believed the teacher thought they were doing work and would not notice that they were looking up web sites, checking email and playing games. Students compared this behaviour to the overt action of getting up and playing with the dogs that they felt would be conspicuous and draw negative attention. For example, Wynnie explained that, "if we all got up and played with the dog, she [the teacher] would notice."

The indicators of elements of oppression described by students resonate with those described by the teacher. For example, Sam felt that she was, "on probation," and that that Tanya had control over the class, the teaching style and methods used that included the way people used the computers. Sam also said that felt she did not have control over the class or the behaviour of students.

It is speculated that the elements of oppression described by students and the teacher may have been a reflection of the underlying hierarchical power and control structures operating in the environment. The data analysis reported at Appendix L, suggests that several students felt subordinate to teachers, could not be themselves, and had to play within the expectations of the character of a student. Several students also commented that the dogs were subordinate to students in the social structure of the classroom. The underlying hierarchical power and control structures operating in the environment were also suggested by the seating arrangements that put the teacher at the front, and by aspects of authority that are reported at Appendix K. In this context, students appeared with limited agency or political voice, and had narrow control over their environment.

When interpreted as elements of oppression, these indicators may have moderated people's preferences in the Active (A), Initiating (I) and Spontaneous (S) dimensions by fostering ways of engaging with the dogs that were more reFlective (F) and Responding (R). They may also have fostered ways of interacting with the dogs that were not conspicuous and that were Planned (P) where structured breaks were seen as the appropriate time to interact with the dog. This further suggests that people may have experienced low grade stress arising from annoyance, frustration and what may be interpreted as elements of oppression that may also have operated on people's preference in similar ways to those reported by Briggs-Myers (1980).

It appears ironic that through the lens of oppression, one of the interesting findings about how people used the dogs as mediating artifacts emerges. Only two students directly voiced their concerns to the teachers. However several students, along with Sam, appeared to use the dogs as vehicles to voice their thoughts and concerns. This was suggested by what appeared to be latent messages conveyed within the

comments made by students when talking to and about the dogs. These latent messages concerned the temperature in the room, the degree to which they were stimulated, their enjoyment of the course, and their self-efficacy. Similarly, Sam's comments also appeared to convey latent messages about her awareness of the students' cognitive load, her self-efficacy and anxiety, and her awareness of the students' stimulation. A further indicator of elements of oppression was suggested by the way these voices went unacknowledged by the teachers.

The notion that participants used the dogs directly or through representation as vehicles to voice their thoughts and concerns resonates with the ideas of Burt (2001) and McKay (2001). It was pointed out in chapter 1 that Burt (2001) and McKay (2001) suggest that through representation and anthropomorphism, animals become bearers of human concerns and are used to voice human ideas by acting as proxies and speaking for humans. Keeley (2004) and McKay (2001) argue that anthropomorphism is taboo in scientific study. However, Burt (2001) and Marvin (2001) suggest a central notion of anthropomorphism is the use of animals as the bearers of human concerns to voice ideas. In this way, the dogs may have functioned as artifacts by helping people present hidden and inner thoughts or suppressed self-talk in a manner that was safe and easy for others to understand. The anthropomorphised dog may thus have helped people present that which may otherwise have remained unseen by others. In this way, the dogs may also have factored in the construction of people's social relationships by providing them with additional information on which to make judgements and decisions about others. In a similar way, the use of the dogs to voice ideas may have helped people verbalise and externalise their unconscious thoughts and thus made conscious to the self that which was previously locked in the realm of the unconscious. This may suggest that for

some people, the use of the dogs to voice ideas may have reflected their unconscious thoughts that in turn may ultimately lead to greater self-awareness and understanding.

Lore versus Law: Establishing Rules for Behaviour

A further factor that appears to have operated on people's preferences may have been the emergence of spoken and unspoken rules concerning people's interaction with the dogs. For example, at the beginning of the course the researcher explained to participants that they were free to interact with the dogs at any time, and in any manner that they felt comfortable and that was safe for the dogs and others. However, only two students got out of their chairs and actively played with the dogs. One explanation for this may have been the emergence of unspoken rules regarding when it was acceptable to interact with the dogs. For example, several students described the breaks and, "slack off time," as the most appropriate time to interact with the dogs, and that they, "didn't feel appropriate to do it [play with the dog] in that work time." Sam explained that work time was time when it was, "acceptable for them to get up and go and make a coffee; it was acceptable for them to get up and go to the toilet; it was acceptable for them to get stuff off the printer because that's work."

For Leigh, a further rule that appeared to emerge, which may have operated on her preferences, was the need to keep the dogs away from Reggie, whom she perceived did not like dogs. The emergence of unspoken rules regarding the behaviour of the dogs, was suggested by participants who described the dogs' active, gregarious and outgoing behaviour as attractive, and those who described the intrusion by stray dogs as unacceptable.

The emergence of unspoken rules was also suggested by the teachers' interaction with the dogs. For example, Sam commented that, "I didn't play with the dog when I was passing information onto them...I played with the dog when they were

on task doing something else. So that could have also been a bit of yes, modelling behaviour.” Similarly, Alma may have implied that it was not acceptable for people to interact with the dogs by ignoring them. This suggests that the teachers’ interaction with the dogs may have operated on people’s preferences by implicit rule making. These implicit rules appear to have emerged from the teacher demonstrating particular ways of interacting with the dogs and by modelling selective behaviours.

The emergence of unspoken rules may have moderated people’s preference in the Active (A), Initiating (I) and Spontaneous (S) dimensions by discouraging their outgoing, gregarious and enthusiastic interaction with the dogs. They may therefore have fostered conformance to normative behaviour in the reFlective (F), Responding (R) and Planned (P) dimensions.

Reported at Appendix K is an analysis of teacher and student behaviours that suggest the emergence of unspoken rules regarding other behaviours. These behaviours included leaving the room, getting printing, getting drinks and using mobile phones. The patterns of these behaviours resonate with and appear to support the emergence of unspoken rules regarding people’s interaction with the dogs, and may deepen an understanding of how they emerged. The patterns of these behaviours seemed to surface slowly, and occurred infrequently at the beginning of the course. They increased over time, appeared to have durability for the length of the course, and ostensibly went unquestioned by both teachers and students. However, further evidence appears to imply that their acceptance was not universal. For example, on one occasion when Mark’s phone rang, Sam commented that, “We don’t like Mark’s phone.” Similarly, as Mary explained, she felt the use of mobile phones was not acceptable:

Well, I do find the mobile phone, well, its one non-rule, a bit unusual...Certainly having a mobile phone in the room, and letting it ring and

then answering it...while someone's presenting. Yes, that surprised me and no one said, "People could we turn our phones off?" That surprised me.

The patterns of these behaviours suggest that normative rules may have been cultivated by the apparent tacit approval they received, and by people observing the behaviour modelled by others. Tacit approval was suggested by the absence of negative consequences. The absence of negative consequences was suggested by the few occasions Sam attempted to correct students when they engaged in social conversation, and by Sam's description that she did not have control over the classroom or students' behaviour. The tacit approval given to behaviours through lack of consequences, either reward or punishment, suggests that they may have been fostered by Bandura's notion of vicarious reinforcement (Bandura, 1977). For example, observing other people using mobile phones or leaving the classroom without consequence may have reinforced the acceptability of these behaviours. However, vicarious reinforcement through tacit approval did not appear to figure in people's Active (A) and Initiating (I) interaction with the dogs as suggested by the way Andy's and Mark's outgoing, gregarious and enthusiastic playing went unquestioned and unrewarded, yet was not imitated by others.

The emergence of unspoken rules regarding people's interaction with the dogs through modelled behaviour resonates with the way other animals learn how to use artifacts through observational learning as suggested by Baber (2003). It also appear to be supported by social learning theories purported by Ormond (1999) and Bandura (1977), who suggest that people learn by observing the behaviour modelled by others.

The emergence of unspoken rules contrasts with those that were formally established in written form. Unlike Nicholls (2006) who reported that her Year 7 students constructed a set of guidelines for taking responsibility for her dog, participants in this study did not construct a set of formal rules regarding their

interactions with the dogs. They were noticeably absent when the teacher attempted to establish a formal set of agreed ground rules for classroom behaviour. However, as Borat explained, such formal rules in written form may have had fewer efficacies than rules that were implied or unspoken:

Reggie said, “Hey, relax this is, just not even five minutes ago we put all these rules down and you are ignoring them now, you know...it’s like one of those things, when you have put a budget. You know people perceive it as bullshit, even though we participate in it...We work on it, we put what we want...and then you forget about it. It’s weird.”

In summary, this discussion points towards the emergence of unspoken rules and the development of normative behaviour as factors that may have operated on people’s preferences. The efficacy of unspoken rules, which also appear to have emerged regarding the behaviour of the dogs, appears to contrast with the ostensible futility of formal rules that seemed to be forcibly cultivated. Unspoken rules regarding people’s interaction with the dogs appeared to develop by people observing the behaviour modelled by others, by the teacher showing and teaching people ways of using the artifact by modelling behaviour, and by the use of vicarious reinforcement through tacit approval. This appears to resonate with the way unspoken rules regarding other behaviours emerged. However, vicarious reinforcement through tacit approval did not appear to figure in people’s Active (A) and Initiating (I) interaction with the dogs.

Perception

A further factor that may have operated on individual preferences may have been the effects of attention and habituation, and orientation and culture on people’s perception of the dogs. Selective attention describes the voluntarily focusing on a single object while excluding others (Coon & Mitterer, 2010). The failure of people to

perceive the dogs through selective attention was suggested by several students who explained that their focus on learning and the course content was superordinate to their awareness of the dogs. For example, Coral explained that, “you’ve really got to stay pretty focused on the delivery.” The influence of selective attention was exemplified by Morgan who explained that she withdrew into, “like a zone of learning something, that’s pretty much where I stay. I block out everything else.”

Habituation describes the diminished response to a stimulus after repeated predictable and unchanging presentations (Coon & Mitterer, 2010). For example, a novel sound may initially draw attention. However when played repeatedly, response to the sound diminishes as people become accustomed to hearing it. The failure of people to perceive the dogs through habituation was suggested by several students who explained that because they quickly became familiar with them in the classroom, and were familiar with dogs in other contexts, they forgot the dogs were there. The influence of habituation was exemplified by Dan who explained that, “sometimes I don’t think people knew they were there...Certainly interesting from the first day, but after the second, third, fourth day on, they were there, that was fine, they were part of the process.”

A further aspect that may have factored in people’s perception of the dogs may have been their orientation, that is, the extent to which people described whether they liked dogs, as reported through the pre-course questionnaire. For example Brad was the only participant to rate his orientation towards dogs as 1 (*don’t like dogs, but will tolerate them*). Morgan who did not complete the pre-course questionnaire, described her orientation towards dogs as as 2 (*don’t like dogs, but will tolerate them*). Both Brad and Morgan described how dogs did not figure in their field of vision. For example,

Morgan explained that, “I’ve never had an animal, never been an animal person, so I generally don’t pay attention to them.”

Culture may also have factored in people’s perception of the dogs. The influence of culture on perception is often thought of in terms of the differences between European, American and Asian cultures (Coon & Mitterer, 2010). For example, people from European and American cultures tend to focus on themselves and their sense of personal control, and tend to perceive changes in foreground objects. This contrasts with people from Asian cultures who tend to focus on their personal relationships and social responsibilities, and tend to perceive changes in background objects (Coon & Mitterer, 2010). In this study, the data analysis suggests that similar differences between metropolitan and rural cultures in Queensland, Australia may have factored in people’s perceptions of the dogs, and may have moderated their Active—reFlective (A—F), Material—Conceptual (M—C) and Spontaneous—Planned (S—P) interaction with them. For example, Andy, Brad and Wynnie explained that the difference between people from metropolitan areas and those from rural areas was that the later were quiet, reserved and reflective, and operated at a slow pace to the former. Brad described dogs as working animals, and as commodities that could be bought or sold often for low monetary value. Brad also said that he would not, “go out of my way to muck around with the dogs,” that he would not allow them within the fence of his property and that for him, the barking behaviour of dogs signaled a warning that there was a problem or that something was wrong. The influence of culture on people’s perception of the dogs also appears to point towards enculturation as another factor that may have operated on people’s preferences.

Enculturation

As discussed in the chapter 1, enculturation refers to the embodiment within an artifact of certain values and behaviours appropriate to a particular culture that create normative behaviour and suggest a certain way of using it (Baber, 2003; Grusec & Hastings, 2007; Guribye, 2003). The operation of enculturation on people's Material—Conceptual (M—C) and Spontaneous—Planned (S—P) preferences was evidenced by several students who described how their cultural beliefs and values positioned dogs as working animals who function in concrete and practical ways with structure and purpose. For example, Wynnie described Adonis as a city dog who, “does paper runs,” which she contrasted with working dogs from rural areas. This resonates with Brad and Andy's description of dogs as working animals of utility and as commodities.

The influence of enculturation on people's preferences was also suggested by several participants who described characteristics that they most often associated with different breeds of dogs. For example, several participants described Labradors as smart, social dogs who assisted the visually impaired and who were gentle with children. In contrast several participants described German Shepherds as aggressive, vicious and intelligent dogs who were well-trained, who were often used as guard dogs, and occupied roles in security, prisons, police and armed services. The operation of enculturation on people's preference was exemplified by Sam who explained that, “they [the students] actually did interact with Buddy and Adonis more than they interacted with Lady, and I do think it's because she's a German Shepherd.”

Enculturation also appears to point towards another factor that may have operated on people's preferences, that is, the way the dogs functioned and operated in the environment, constituted by their behaviour and the characteristics that people found appealing.

Artifact Functioning and Appeal

The analysis of observational data revealed patterns of the dogs' behaviour that may be described as: active and wandering; barking and tail wagging; spontaneously initiating interaction with people; lying quietly; and responding to the actions of others. These patterns appear to describe the way the dogs functioned and operated in the environment. Furthermore, these patterns appear to resonate with the descriptions of the four dimensions of artifact use. For example, wandering and barking appears to resonate with the outgoing, gregarious and enthusiastic characteristics that describe the Active (A) dimension. Similarly, Adonis' behaviour of approaching, pushing his nose towards people and whimpering appears to resonate with the instigative characteristic that describes the Initiating (I) dimension. In the same way, Lady's behaviour of lying quietly and acting in response to people's behaviour appears to resonate with the quiet, contained and personal characteristics that describe the reFlective (F) dimension. Correspondingly, Adonis' barking and becoming entangled in cords, and Buddy's impulsive jumping towards people, appear to resonate with the casual, spontaneous, emergent and open-ended characteristics that describe the Spontaneous (S) dimension. Buddy's formal introduction to people appears to resonate with the disciplined, scheduled and methodical characteristics that described the Planned (P) dimension.

The descriptions of characteristics of the dogs that people found appealing also appear to resonate with the descriptions of dimensions of use, and at the same time, appear to add support to the operation of individual preferences. For example, the characteristics that most people found appealing in Adonis and Buddy were energy, physical attractiveness, initiating, and spontaneous puppy-like behaviour. This appears to suggest a preference for the outgoing, gregarious, initiating, material and spontaneous functioning of the dogs. This preference appears to resonate with the

descriptions of the Active Initiating Material and Spontaneous (AIMS) dimensions. Similarly characteristics that some people found appealing in Adonis and Buddy were personality, bond and eye contact. This appears to suggest a preference for the creative, imaginative and abstract functioning of the dogs. This preference appears to resonate with the description of the Conceptual (C) dimension. In the same way, characteristics that students did not find attractive in Lady were lying passively, being well-trained, and responding to people's interaction. This appears to suggest an inverse preference for the quiet, contained, responding, scheduled, disciplined and planned functioning of the dogs. This preference appears to resonate with the contrasting descriptions of the reFlective Responding and Planned (FRP) dimensions.

The different patterns of behaviour that constituted the dogs' functioning, and the different characteristics that people found appealing, suggests that different people may have perceived different affordances¹⁶ for using the dogs, which may have operated on their preferences. For example, the Initiating (I) functioning of the dogs, which was characterised by approaching, pushing their noses towards people and whimpering, may have suggested Responding (R) affordances. These affordances may have conveyed ways of interacting with the dogs by reacting to their behaviour. Similarly the reFlective (F) functioning of the dogs, which was characterised by lying down, may have suggested reFlective (F) affordances. These affordances may have

¹⁶ Latour (1992) and Norman (1988) describe affordances as the perceived and actual properties of an artifact that provide clues, and suggest a certain way it can be used. For example, a handle suggests a certain way of holding a cup, a ball suggests throwing or bouncing and a knob suggests turning.

conveyed ways of interacting with the dogs that are quiet, personal and reserved, such as watching and observing.

The way most people seemed to find the Active Initiating (AI) functioning and characteristics of the dogs most appealing, and the way people appeared to interact with the dogs principally in the reFlective and Responding (FR) dimensions, appears to suggest a possible relationship between functioning, appeal and preference. For example, people with a preference for Active (A) interaction may have found the functioning characteristic of energy congruent to their preference. They may therefore have only perceived the outgoing, gregarious and enthusiastic affordances and may not have been cognisant of ways of interacting with the dogs in ways that were quiet, personal and reserved. Alternatively they may have found those ways of interacting unfamiliar or uncomfortable. In contrast, people with a preference for Material (M) interaction may have found the functioning characteristic of bond, personality and eye contact complimentary to their preference. They may therefore have perceived the concrete, practical and physical affordances, as well as the conceptual, abstract and imaginative. The suggested relationship shared between functioning and appeal through perceived affordances and preferences of dimensions of use is exemplified by Sharon's comment that:

It wasn't as if, if you were an introvert, you wouldn't find a dog that was as quiet as you wanted to be, or if you wanted to be a really, like Andy was, you know with Buddy, out there. So it wasn't like you were just stuck with one dog with one personality type.

In summary, this discussion may suggest that people's interaction with the dogs may be understood by aspects of functioning and appeal, that may share a relationship with individual preferences.

Relationship to Other Studies

The dimensions of artifact use suggested by this study resonate with the way dogs and other animals have been used in therapy and childhood education settings. For example, one study by Katcher et al. (1983) that looked at the physiological effects of observing animals and pictures of animals, may be seen as an example of reFlective Responding Material Spontaneous (FRMS) use of the artifact. Similarly, the use of dogs in studies situated in therapy settings by Burgess (1997), Crowley-Robinson et al. (1996), Henderson (1997) and Myers (1998), may be seen as examples of the Active Material Planned (AMP) dimensions. In the same way, the method of using dogs in structured educational programmes such as *Reading with Rover*, *Paws to Read* and *Reading Assistance Education Dogs* described by Townsend (2003), may also be seen an example of the Active Material Planned (AMP) dimensions. Equally, the way Lacoff (1999) reported Boris Levinson's use of his dog to build rapport and dialogue with patients, suggests a quiet, personal, contained, spontaneous responding to the material and practical use of the dog that may be viewed as reFlective Responding Material Spontaneous (FRMS).

However, in many of these studies the animals appear to be used in one principal dimension, for example, either Active (A) or reFlective (F), Material (M) or Conceptual (C). The single manner of artifact use resonates with the suggestion by Engeström (1987) that artifacts are often seen through their principal function and affordances. However, it is proposed that using the artifact in principally one dimension may account for some of the variance in results produced by studies into animal-human interaction. One reason for this may be that for some people, the principal functioning or use may be incongruent with their individual preferences. For example, people with an Active (A) preference may find it difficult and stressful to interact with dogs in ways

that are quiet, contained and personal because those methods are unpractised, uncomfortable and unfamiliar. However, the results of this study suggest that there may be opportunities for different people within the same setting to use the same artifact in different ways through the use of individual preferences.

The way many studies appear to use animals principally in one dimension resonates with the researcher's initial expectations. At the beginning of this study, the researcher anticipated that people's interactions with the dogs would principally be in active and material ways that would be overt and directly observable such as patting, playing and feeding. People's limited Active (A) and Material (M) interaction with the dogs aroused initial concerns that people were not interacting with the dogs, and therefore the dogs could not be seen to be functioning as artifacts. However, the results of this study suggest that artifact use may not be limited to active and material ways that are overt and directly observable. They also suggest that meaningful functioning may manifest itself in passive, reflective, conceptual and representational ways that appear to be less overt or obvious. Additionally, covert uses of the dogs such as quiet patting and observing, which appeared principally through the reFlective (F) and Conceptual (C) dimensions where the object of mediation seemed to be intrapsychological, may go largely unseen by others. This may suggest that caution should be exercised in drawing the conclusion that when a dog is lying around, or when people are not actively patting and playing with a dog, that they are not using or interacting with it.

Summary

This chapter discussed the interpretation of the data analysis, and explored answers to the two research questions: In what ways do people use dogs as mediating artifacts in their meaning-making processes; and what are the effects of dogs in mediating individual and group learning processes? To be able to plausibly answer the

first research question, this discussion adopted the somewhat unconventional approach of answering the second research question first to establish the premise of *use*; a premise that implies purpose or outcome.

To answer the second research question, the results of this study suggest that the mediating role of the dogs may be understood by the way they appeared to have function as artifacts in three domains of the learning environment: cognitive, affective and social. The dogs may be seen to have functioned as artifacts in the cognitive domain by stimulating arousal, attention, focus and concentration through positive distraction. In the affective domain, the dogs may be seen to have functioned as artifacts by: triggering positive emotional responses to arousal; stimulating feelings of enjoyment, calm, warmth and peace; and by fostering a relaxed and informal atmosphere by moderating the unpleasurable aspects derived from elements in the task environment. The dogs may be seen to have function as artifacts in the social domain by: serving as a social ice-breaker and providing a value-free conversation starter; and by functioning in people's perceptions of others through the use of social axioms, which may have factored in the construction of their social relationships.

Having established the premise of use, answers to the first research question were then explored, and the discussion examined the patterns of people's interactions with the dogs in four dichotomous dimensions: Active—reFlective (A—F), Initiating—Responding (I—R), Material—Conceptual (M—C) and Spontaneous—Planned (S—P). The descriptions of these dimensions appear to resonate with three of the Big Five dimensions of personality, which have been used to understand the different ways in which people learn. This suggests that people's use of dogs as artifacts may share possible relationships with dimensions of personality and people's learning styles. Exploring these relationships suggested a previously hidden dimension of artifact use,

Emotional—Logical (E—L), that may be congruent with a further dimension of personality, Agreeableness.

The discussion further suggested that these dimensions appear to share dynamic relationships that may provide a deeper understanding of how people used the dogs as artifacts by looking at how the dimensions work and interact together. The discussion also revealed the functioning of individual preferences within the dimensions that may have been moderated by a number of factors, which paradoxically provide further evidence of the functioning of individual preferences. These factors included: the context; the physical environment; ease and effort; what may be interpreted as elements of oppression; rule making; perception; enculturation; and artifact functioning and appeal.

The final chapter will present a summary of the key findings and conclusions of this study, along with their implications for practitioners, and will explore the value of further research. It will also examine the significance and limitations of this study, along with key learnings that arose from the researcher's use of the dog as artifact, and learnings that emerged from the researcher's reflections on the methodological approach.

CHAPTER 6: SUMMARY AND CONCLUSIONS

Introduction

The aim of this research was to explore and develop a framework for understanding the mediating role of dogs in people's learning processes in vocational education and training settings. It set out to achieve this by answering two research questions: In what ways do people use dogs as mediating artifacts in their meaning-making processes; and what are the effects of dogs in mediating individual and group learning processes?

This research was founded on the question: If animal—human interactions can help realise cognitive, affective and social benefits in therapeutic and childhood educational settings, what is their potential for adult learners? The choice of dogs as the animals for this research was informed by their use in animal assisted therapy and education settings. They are also the subject of a large number of studies that were drawn on to help shape and inform this research. It was further informed by the rich symbiotic co-evolution and relationship they enjoy with humans that is unequalled by any other domestic animal.

This study focused on the lived experiences and reflections of 15 students and their teachers who interacted with three dogs during a six and a half day vocational education and training course. The course was held in a major regional centre in northern Australia by a private training provider. The course, *TAA40104 Certificate IV in Training and Assessment*, is the entry-level qualification required for practitioners to deliver and assess accredited training. It was chosen as the learning context in this research because it was a representative example of classroom-based training located in the vocational education and training sector.

Lincoln and Guba (1985) and Miles and Huberman (1994) suggest that the value and significance of qualitative research, and the conclusions that are drawn from it, are judged against criteria for trustworthiness. Trustworthiness in this research was operationalised as credibility, transferability, dependability and confirmability. Credibility was achieved through considering the size of the sample, prolonged engagement, persistent observation, triangulation, peer debriefings and negative case analysis. Transferability was address through the use of thick descriptions that provide the reader with an understanding of: the macro-, mezzo- and micro-environments within which the research was conducted; the people participating in the research; the time and context within which the research results were found to hold; and rich narrative through the use of the repertory grid technique. Dependability was achieved by using methods of triangulation that were used to establish credibility. Finally, confirmability was achieved by establishing an audit trail and by providing a thick description of the role of the researcher.

This research used six techniques to collect data: a pre-course questionnaire, classroom observations, critical events technique, repertory grid technique, post-course interviews, and the researcher's personal journal. A pre-course questionnaire was used to capture demographic data about the participants and to help build a picture of their backgrounds. Classroom observations were recorded for the duration of the course using running records, and semi-structured interviews were used to capture perceptions and reflections on people's experiences following critical events that occurred during the class. The repertory grid technique enabled people to verbalise how they perceived elements or facets within the classroom domain, which helped construct a picture of their concept models. It also served as a tool for the collection of students' and teacher's narratives at the completion of the course

by stimulating dialogue. Finally, the researcher's journal revealed information about self and method at regular and spontaneous moments during the life of the study.

Analysis of the interview and observational data drew on grounded theory to develop hypotheses to explain identified phenomena. It used an iterative analytical process that employed two inductive strategies. First, it used constant comparison where concepts and categories that emerged from one piece of data were compared with others to explore the possible relationships between them. Second, it used analytic induction where hypotheses were formulated around an instance of a phenomenon, and through an iterative process of comparison with other occurrences, continually refined to account for all of them. Repertory grids were analysed using Idiogrid (Grice, 2007) and GridSuite (Bacher & Fromm, 2004) software to produce bivariate statistics, and conduct principal component and cluster analyses. Bivariate statistics were used to examine the relationships between constructs and elements. Principal component analysis was used to compress constructs to a smaller number that accounted for the spread of data. Cluster analysis was used to examine natural groupings amongst constructs and elements, and the similarities and differences they shared.

No research is without bias and as Lincoln and Guba (1985) and Miles and Huberman (1994) suggest, the researcher is bound to reveal these to establish confirmability. The most notable bias in this study arose from the researcher's role as observer-as-participant. The researcher did not assume the role of an active participant in the classroom, yet as Atkinson and Hammersley (1994) argue, merely being present in the environment may have constituted participation that could have influenced people's behaviour and social interactions. This was evidenced by Mary's comment that:

I think the fact that you were there with the dogs had an influence, on that they felt that they were being observed. I just felt they were conscious of you being there...and you weren't one of the students. I think it might have made them a little bit more conscious of what they did...I think they assumed that...they could sort of pull the wool over everyone's eyes and you know, we wouldn't ask any questions. And yet when you were there, you might have had that knowledge.

Another bias may have arisen where people who had prior knowledge of animals in therapeutic settings, may have told the researcher what they believed the researcher wanted to hear. A final bias may have arisen from the presence of the handler. This may have positioned the dogs as separate to students, and as belonging to someone else, and may have implied that the handler alone was responsible for attending to the dogs' needs such as controlling behaviour and toileting. This was evidenced by several students who, like Brad, said that the dogs were, "not my problem...it's the people who own the dog, he does it." These comments appear to suggest that students may have felt constrained in interacting with the dogs because the dogs belonged to someone else, and because they were uncertain of what was permissible such as feeding or taking for a walk. Conversely, these comments may suggest that students abdicated responsibilities for the welfare of the dogs, which may point towards a limited understanding of what those responsibilities were. Additionally, the handlers' behaviour may also have biased the way some people interacted the dogs by restraining them and leading them towards other people.

It is recommended that future researchers alleviate these biases by educating students and teachers about the dogs' needs, their responsibilities for their welfare, and what is permissible when interacting with them. Additionally, future researchers

may wish to consider removing the handler in situations where the teacher is willing and capable for oversight of the dogs' needs and welfare; possibly sharing these responsibilities with students. This may have the additional benefit of fostering greater interaction with the dogs by modelling behaviour.

The ethical requirements for conducting this research included privacy, confidentiality, security, health and safety. These requirements were met through a formal review process with James Cook University's Animal Research Ethics Review Committee and Human Research Ethics Review Committee. Formal approval was received from both committees (approval numbers A1149 and H2455). The research was then conducted according to those requirements.

Artifact Use

The first question that this research aimed to answer was: In what ways do people use dogs as mediating artifacts in their meaning-making processes? The results of this study suggest that there were four dichotomous dimensions of the participants' use of the dogs: Active—reFlective (A—F), Initiating—Responding (I—R), Material—Conceptual (M—C) and Spontaneous—Planned (S—P). Reported in Table 50 are descriptions of these dimensions. These dimensions appear to resonate with the descriptions of three of the Big Five dimensions of personality described by McCrae and John (1992): Openness, Conscientiousness and Energy. The Big Five dimensions of personality have also been used to understand the different ways in which people learn. In addition, patterns emerged from the interview data that provided a clue to a dimension of artifact use that was absent from the observational data, Emotional—Logical (E—L). This dimension appears to be congruent with the Big Five's Agreeableness, and with Serpell's motivational

Table 50

Descriptions of Dimensions of Artifact Use

Emergent pole	Implicit pole
Active (A)—reFlective (F)	
Outgoing, gregarious and enthusiastic interaction with the dogs, displaying a sense of external energy by patting, hugging, playing, feeding and coaxing the dogs.	Contained, personal and quiet interaction with the dogs, displaying a sense of internal energy by: quietly sitting and watching the dogs and smiling or laughing; sitting and patting the dogs as they walked past; talking about the dogs with other people; and stepping over the dogs.
Initiating (I)—Responding (R)	
Instigating interaction with the dogs, attracting the dogs, starting interactions with others by talking about the dogs, commencing play by offering the dogs objects to play with, and by offering food to the dogs.	Reacting to the behaviour of the dogs by observing, watching or patting them.
Material (M)—Conceptual (C)	
Concrete, practical and physical interaction with the dogs by playing, patting, coaxing and feeding them.	Abstract, conceptual and imaginative interaction with the dogs by incorporating representations of them

Emergent pole	Implicit pole
<p data-bbox="900 367 1315 477">in presentation or exercises; and speaking about them.</p> <p data-bbox="660 517 1054 551">Spontaneous (S)—Planned (P)</p> <p data-bbox="312 591 799 768">Casual, spontaneous, emergent, open-ended, unplanned and unstructured interaction with the dogs.</p>	<p data-bbox="900 591 1390 701">Structured, disciplined, scheduled and methodical interaction with the dogs.</p>
<p data-bbox="676 810 1038 844">Emotional (E)—Logical (L)</p> <p data-bbox="312 882 823 1137">Being empathetic, emotional, compassionate, accommodating and values-driven when interacting with the dogs.</p>	<p data-bbox="900 882 1398 1066">Being logical, questioning, critical, tough and reasonable when interacting with the dogs.</p>

determinants of people's attitude towards animals that he referred to as Affect and Utility (Serpell, 2004). These congruencies suggest that the participant's use of the dogs as artifacts may share possible relationships with dimensions of personality and people's learning styles. Additionally, the dimensions of artifact use appear to share dynamic relationships. These relationships may provide a deeper understanding of how the participants used the dogs as artifacts, by illustrating how the dimensions worked and interacted together. Figure 15 expresses these relationships as a matrix where each one can be stated in the form of a four element string. The most frequently occurring can be stated in the form of a four element string. The most frequently occurring dynamic for participants in this study was reFlective Responding Material and Spontaneous (FRMS). The results of this study

		Initiating		Responding	
		Material	Conceptual	Conceptual	Material
reflective	Planned	FIMP	FICP	FRCP	FRMP
	Spontaneous	FIMS	FICS	FRCS	FRMS
Active	Spontaneous	AIMS	AICS	ARCS	ARMS
	Planned	AIMP	AICP	ARCP	ARMP

Figure 15. Matrix of dynamic relationships between dimensions.

also revealed the functioning of individual preferences within the dimensions of artifact use. These preferences appear to have been moderated by a number of factors. These factors included: the context; the physical environment; ease and effort; what may be interpreted as elements of oppression; rule making; perception; enculturation; and artifact functioning and appeal.

Put simply, the results of this study suggest that different participants used the dogs as mediating artifacts in different ways that may be understood by the theoretical equation, $au = d \times pf (e \times p \times f \times a)$, where artifact use (au) may be understood as a product of dimensions of use (d) and preference (pf), modified by

the product of: environment (*e*) that included the context, physical environment, ease and effort, what may be interpreted as elements of oppression; rule making; the way the artifact was perceived (*p*) including its enculturation; the way the artifact operated and functioned (*f*) in the environment; and characteristics that people found appealing (*a*), which may suggest preferences for certain affordances.

Mediation

The second question that this research aimed to answer was: What are the effects of dogs in mediating individual and group learning processes? The results of this study suggest that the mediating role of the dogs may be understood by the way they appeared to have function as artifacts in three domains of the learning environment: cognitive, affective and social.

The dogs may be seen to have functioned as artifacts in the cognitive domain by stimulating arousal, attention, focus and concentration. This occurred in several ways. First, the dogs appear to have aroused students by drawing attention to them by barking, playing, and wandering. This may have stimulated people's state of responsiveness by creating interest and relief from boredom. Second, the dogs seem to have stimulated attention by providing short spontaneous breaks that offered reprieve from cognitive fatigue, and allowed people to refocus on the learning tasks with increased energy. Third, the dogs may have helped reduce the occurrence of attentional breaks by offering arousal and attentional reinforcement in a continual flow rather than when attention was partially or fully depleted. The dogs therefore, could be viewed as precautionary rather than remedial in stimulating concentration. They also appear to have functioned as a visual focus that may have aided students' ability to attend to incoming information by reducing competition on cognitive resources from undesirable stimuli, and thus reduced instances of daydreaming.

The mediating role of dogs in participant's cognitive processes may be understood by the way they appear to have functioned as artifacts by being anchored in the present and imbued with a sense of now and the moment, and through what participants described as a "positive distraction." Further, this mediation occurred through one source, the dogs, rather than through two or more sources of stimulation. Additionally, it occurred at times and in ways that were individually determined to be most relevant and meaningful.

The dogs may be seen to have functioned as artifacts in the affective domain by: triggering positive emotional responses to arousal; stimulating feelings of enjoyment, calm, warmth and peace; fostering a relaxed and informal atmosphere that may have factored in the emotional climate in the classroom; and by moderating feelings of stress and anxiety and unpleasurable aspects derived from elements in the task environment. They did this by fostering initial responses of surprise, fright and shock that for many were accompanied by feelings of fun, excitement, humour and amusement. For others, they fostered initial responses of being afraid, unnerved, upset, worried, anxious and stressed that were short-lived. These responses were quickly followed by a positive emotional residue that arose from the dogs' unpredictable, mischievous, spontaneous and neotonistic behaviour. These emotional responses were reflected by people who smiled when they watched the dogs, and laughed at their behaviour.

The dogs appear to have fostered a relaxed and informal atmosphere by stimulating a sense of normalcy, everydayness and connection with the outside world, which people reported made them feel comfortable with their surroundings. This created an atmosphere where students reported they felt they were able to learn more and were able to talk more freely. The dogs also appear to have functioned as

artifacts by moderating feelings of stress, anxiety and tension. However many students described the moderating effects through generalised supposition for others, rather than themselves. This implies these results were not universal and point to a potential bias arising from people with previous knowledge of dogs in therapeutic settings, saying what they believed the researcher wanted to hear.

When understood in these ways, the mediating role of the dogs in this study appears to resonate with the findings of similar studies in therapeutic and childhood education settings. However, this research points to the new understanding that these phenomena may not be limited to therapeutic and childhood education settings and may also occur amongst adults in vocational education and training. The examination of the processes that took place during these interactions also provides new knowledge by offering a framework to understand how and why these interactions make the results reported by researchers possible.

The dogs appear to have functioned as artifacts in the social domain by: serving as a social ice-breaker and providing a value-free conversation starter; and by functioning in people's perceptions of others through the use of social axioms, which may have factored in the construction of their social relationships in the classroom. They did this by fostering elements of group forming that may have aided people to orient themselves towards each other, avoid conflict, and rely on safe, patterned behaviour. When interpreted this way, these findings resonate with the established descriptions of dogs as social catalysts and facilitators who engender trust and stimulate safe conversation. However other established processes for effective group functioning, storming, norming, performing and mourning, were absent.

In the absence of established processes, the social dynamics and group functioning were characterised by the formation of social factions where people understood themselves in similar ways to people whom they were seated next to or near, and in different ways to people who were seated further away. Similarly, they reported interacting most with people who were close to them, and least with those who were further away. These social factions placed Coral, Reggie and Lady as outliers and socially separate from others who viewed them as the most unapproachable, untrustworthy, formal, disciplined, aloof, critical, guarded, cold and alone of all participants.

The dogs also appear to have mediated in the social domain by functioning in people's perceptions of others through their use in social axioms, which may have factored in the construction of their social relationships in the classroom. They did this by acting as a measure against which students evaluated the trustworthiness, approachability and sociability of others. They were used by students to appraise the congruence of other's orientation and interactions with the dogs, against their own axiomatic beliefs. The three axiomatic beliefs that people used were: people who like dogs are good people and people who do not like dogs are not good people; people who like dogs care about other people and people who do not like dogs cannot care about others; and people who like dogs are comfortable having them there and people who do not like dogs are not comfortable having them there.

Though the evidence indicates that these axiomatic beliefs operated on people's perceptions of others, it is not known whether they were used in a primary manner to establish perception, or in a secondary manner to validate perceptions derived from other means. However, incongruities between people's perceptions and observed behaviour suggest that this use of the dogs may be founded not on

what existed externally true in others, but on how people understood other's orientation towards dogs, and what they saw of others' interactions with them. Put simply, to establish trustworthiness, approachability and sociability it may be insufficient merely to like dogs. One may also benefit by being seen within people's field of view to interact with dogs in a manner that portrays a positive orientation.

The results of this study also highlight how a teacher who is focused on assessable outcomes and the task environment might view their students' world through that same lens. However, the students in this study viewed their learning environment through a social lens. This raises the possibility of a divide between the teacher's view of the world, and the way her students constructed their learning environment.

Implications for Practitioners

The results of this study indicate opportunities for practitioners to: bridge the teacher—student divide; foster different way of using artifacts; use dogs to mediate cognition and emotion; reconceptualise established notions of distraction and task behaviour; and to understand the different ways of using artifacts, and to show and teach them to others.

Bridging the Teacher—Student Divide

This study raises the possibility for teachers to bridge the teacher—student divide by balancing a traditional focus on the task domain of assessable outcomes, with attention to socialisation and established processes for effective group functioning, and how dogs may factor in those. It also points to the prospect for teachers to recognise that students trust what they see of others' behaviour more than what is said verbally. This suggests that teachers may help bridge the teacher—

student divide by recognising and understanding how their students perceive the world around them and what they hold to be true.

The results further suggest the opportunity for teachers to bridge the teacher—student divide by scaffolding on the affordances offered by people's perceptions and axiomatic beliefs about others' orientation towards dogs and their interaction with them. One way teachers can achieve this, that is suggested by this study, is by being visible in their interactions with dogs. This may help build empathy and trust between teachers and students, and between students themselves. Additionally, this study reveals the prospect for teachers to use their interaction with dogs to foster contact with and amongst students. For example, Morgan explained that if the teacher were to have been visible to others in her interactions with the dogs away from the traditional teaching space, students may have altered the direction in which they were looking. This could have fostered interaction with people other than those near whom they were seated.

Using Dogs to Mediate Cognition and Emotion

This study raises the possibility for practitioners to scaffold on the affordances offered by people's interactions with dogs to mediate their learning processes by stimulating arousal, attention, focus and concentration. One way they can do this, that is suggested by this study, is to foster spontaneous and frequent interactions between students and dogs by modelling behaviour, which also implies alternate rules regarding when and in what ways it is acceptable to interact with dogs in the classroom. Teachers may also wish to consider the use of dogs with active, spontaneous and initiating characteristics to further foster these interactions. However, teachers should recognise the optimal level of arousal that creates positive conditions for learning, and that too much may have the opposite effect.

The results of this research reveal the opportunity for practitioners to scaffold on the affordances offered by people's interactions with dogs to mediate their learning processes by: fostering a positive emotional climate and stimulating a sense of fun, pleasure, enjoyment, warmth, calm, relaxation and informality; and moderating tension, anxiety and stress. The importance of these findings for practitioners is emphasised by the connection between cognition and emotion, where emotions shape how learning is stored in memory, and influence retention and recall.

Reconceptualising Distraction and Task Behaviour

The findings of this study suggest the possibility for practitioners to reconceptualise established notions of distraction in the classroom, including that afforded by dogs, and its possible effects in enhancing learning by stimulating arousal, attention, focus and concentration. In turn, they further indicate the prospect for practitioners to reconsider traditional notions of on-task and off-task behaviour, particularly for younger adult learners in the future, who McCrindle (2009) suggest are both multi-sensory and multi-tasking.

Fostering Different Ways of Using Artifacts

Studies of dogs in therapeutic and childhood education settings suggest that they are used in one principal dimensional dynamic, for example, Active Responding Material Planned (ARMP). However, this study suggests that artifact use can be multi-modal, and one artifact such as a dog can offer different methods for different people. An important lesson arising from this research appears to be that artifact use is not necessarily limited to one dimensional dynamic. Yet, artifact use in the reFlective (F) and Conceptual (C) dimensions, where the object of mediation appears to be intrapsychological, may go largely unseen by others.

Therefore, caution should be exercised in drawing the conclusion that when a dog is lying around, or when people are not actively patting and playing with a dog, that they are not using or interacting with it. The notion of multi-modal use of artifacts points to the opportunity for teachers to provide a variety of opportunities to interact with dogs, and to foster different ways for different people with different preferences to use them.

The results of this research indicate the potential for practitioners to consider how preferences may influence people's use of other artifacts in the classroom, whether in complimentary or contrasting ways. For example, people with a preference for the Material (M) and Planned (P) dimensions, may find using computers, learning guides and reference resources, comfortable and familiar when shown the detailed steps involved in their operation in a linear, structured and sequential manner. In contrast, people with a preference for the Conceptual (C) and Spontaneous (S) dimensions may find these Material (M) and Planned (P) methods frustrating, unfamiliar and uncomfortable. These people might respond with greater ease to being provided with a broad overview of how the computer functions, or to the structure of the learning guides and reference resources. They may then find it more comfortable and familiar to independently explore how best to use them by diving in and out of the content in seemingly random or chaotic ways.

Understanding How to Use Artifacts and Showing Others

This study indicates that if people are to use dogs and other artifacts as tools to mediate their understanding and interpretation of the world around them, they could benefit from clearly understanding how they can be used in different ways, by being shown or taught them. This notion is supported by the suggestion that students and teachers were not adequately taught how to use other artifacts such as

the books, projector and software effectively, which may account for difficulties participants experienced in using them. It is sometimes easy and convenient for practitioners to assume that people know how to use an artifact. However, as the results of this study reveal, such an assumption may be misplaced. For example, putting a computer on a student's desk and asking them to use it to complete a specified task, assumes that the person is skilled in the use of a certain operating system and certain software, which may not always be the case. Similarly, a student might be skilled in the use of technology in one particular way, yet they could be unaware of different methods that may be more comfortable, familiar and less fatiguing. For example, a teacher instructing students how to create a brochure using Microsoft Publisher might specify a structured, lock-step method that for people who prefer an unstructured and exploratory learning style, could be difficult, fatiguing and uncomfortable.

The results of this study therefore raise the prospect for teachers to demonstrate and teach people how to use artifacts in ways that suit their individual needs and learning styles. This study suggests that one way they can do this is to model different behaviours. When people's use of dogs is viewed in a similar way, modelling different behaviours could be one technique that teachers can use to show different methods and techniques for using them. It may also imply alternate rules regarding when and in what ways it is acceptable to interact with dogs in the classroom. These findings also suggest the potential for teachers to foster interaction with dogs in different dimensions and dynamics by considering the use of explicit rather than tacit reinforcement. Another technique may be to structure rich engagement with the dogs. Importantly for practitioners, knowing different methods

that suit individual learning styles, means that teachers can make informed decisions about the way they and their students use artifacts in the classroom.

Implications for Further Research

The results of this research suggest the value of further research to: understand the possible relationships between people's preferences, the dimensions of artifact use, personality and individual learning styles; deepen an understanding of how people's interaction with dogs mediate emotion in the classroom; understand the potential relationship between people's attention spans and the frequency and duration of their interaction with dogs; explore the different ways to structure rich engagement with dogs in vocational education and training settings; explore and understand the ways that dogs may function as artifacts by people using them, to convey their unconscious thoughts; and broaden and understanding of the role and exploring the effects of people's interactions with dogs on the quality of learning and educational outcomes, and the quality of teaching, educational and learning processes.

Dimensions of Use and Personality

This study indicates the worth of further research to explore the nature of the possible relationships between people's preferences for using dogs as artifacts, the dimensions of artifact use, the dimensions of personality, and in turn, individual learning styles. This may contribute to a deeper understanding of the various ways in which different people use not only dogs but also other artifacts in vocational education and training settings. It may also contribute to reconceptualising artifact use to broader environments. Additionally, the results of this research point to the merit of further research to explore the possible existence and nature of the Emotional—Logical (E—L) dimension of artifact use and its potential relationship

with the Big Five dimensions of personality. However, the data analysis did not appear to reveal patterns of the interaction congruent with Neuroticism, which may suggest the value of further research to explore patterns of interaction that might characterise a congruent dimension of artifact use. Understanding preferences of artifact use may help in understanding how people can use artifacts in ways that are comfortable, familiar, and that are most meaningful for them, which could in turn reduce the stress, frustration or anxiety that is often associated with operating artifacts in ways that are incongruent with people's preferences.

Mediating Cognition and Emotion

The results of this study may be limited by their grounding in people's perceptions rather than empirical measures of stress and anxiety. This indicates the value of further research to employ empirical measures of stress and emotions experienced by participants at different points during a course and may reveal deeper understandings of how people's interaction with dogs mediates emotion in the classroom. This study also suggests the merit of further research to understand the possible relationship between individual attention spans, and the frequency and duration of people's interaction with the dogs. Such an understanding could have implications for teachers to determine ways to exploit the affordances of these interactions to help increase attention and concentration during both simple and complex learning tasks.

Structured Engagement

The proposition on which the methodology for this study was founded was that the participation of dogs in the classroom was free-form and unstructured so that people could choose to interact with them in ways and at a times that were most appropriate and meaningful. In other words, this study aimed to reveal emergent,

rather than imposing pre-determined methods of using the dogs. However, in the absence of being shown different ways in which the dogs could be used, people appeared to rely on familiar and traditional patterns of behaviour such as patting, observing and occasionally playing with and talking to the dogs. Consequently, other less familiar and less traditional uses may have taken longer for people to discover and in some cases may have remained undiscovered. In hindsight such an approach may be likened to placing computers at the back of a room and expecting people to discover different ways of using them, that are most meaningful to each individual.

This indicates the possibility of structuring rich engagement with dogs in similar ways that are suggested by their use in therapeutic and childhood education programmes such as *Reading with Rover*, *Paws to Read* and *Reading Assistance Education Dogs*. For example, Townsend (2003) reports that in these programmes, children spend about an hour, once or twice a week, sitting alone with a visiting dog as they practice reading aloud to them. Within the context of this research, such an opportunity existed for students to practice and rehearse their presentations with the dogs before delivering them to their peers. Students may have felt free from negative evaluation as a result of the unconditional positive regard offered by the dogs, and therefore less self-conscious and more confident in presenting to their peers. However, this opportunity like others, such as the structured rich engagement of the dogs during the use of role-play, remained unrealised. Just as computers, televisions or radios are not suitable tools for all teaching and learning situations, the structured rich engagement of dogs may be suited to some situations more than others. This raises the worth of further research to explore the different ways rich

engagement with dogs can be structured in vocational education and training settings.

Voices

The way the dogs functioned as artifacts by people using them to convey their unconscious thoughts suggests the value of further research to explore how these voices, conveyed through the anthropomorphised dog, may factor in the construction of people's social relationships. It may also explain how these voices might lead to greater self-awareness and understanding by reflecting people's unconscious thoughts.

Teaching, Learning and Educational Processes and Outcomes

It was noted in chapter 1 that this research focused on the interactions between people and dogs in vocational education and training settings. Yet the results of this study suggest the merit of further research to broaden an understanding of the role and value of dogs in vocational education and training settings. Such an understanding might be gained by exploring the effects of people's interactions with dogs on the quality of learning and educational outcomes, and the quality of teaching, educational and learning processes.

Significance and Limitations of the Research

This study is significant because it provides new knowledge by offering a framework for understanding the mediating role of dogs in people's learning processes in vocational education and training settings. It therefore provides a map to understand in what ways dogs may be seen to function as artifacts and how this works. It opens up ways of seeing and understanding what may occur in other settings, and provides new ways of being attentive to what happens in the classroom. The examination of the processes that took place during people's

interaction with the dogs also provides new knowledge by offering a framework to understand how and why these interactions make the results reported by researchers possible. It may therefore open the way for improving animal assisted therapy and education programmes, and adapting them to situations beyond therapeutic and childhood education settings.

This study holds significance for practitioners because it provides the opportunity to broaden traditional theories of artifacts and artifact use to include animals alongside the inanimate. It may also extend established understandings of artifacts and their use in the classroom. This understanding suggests the importance for practitioners to know how to use artifacts in different ways, and to show and teach those ways to others. This study holds further significance for practitioners because it reveals insights into how teachers may bridge the teacher—student divide by balancing their traditional focus on assessable outcomes and the task environment, with students' inherently social learning processes.

This study is not without limitations. First, the results are limited to one group of classroom participants, in one environment, across the duration of one six and a half day training course. It therefore provides one instance of one group's use of dogs at one point in time, and the meanings they came to understand from their interactions with them. To this end, this study cannot claim results that are generalisable to other settings, and it does not seek to do so. What it can and does offer is a way to understand and conceptualise what happened for this group of people in this setting. It therefore provides an analytical framework for understanding the mediating role of dogs in people's learning processes on which to scaffold strong theory building when more extensive data is available.

What this study may appear to lack in sample size and duration it makes up for in depth, complexity and richness of lived experience that would not be feasible on a larger scale. However with a limited base of data, the explanations provided are tentative and await refinement and elaboration in the light of more empirical data. This research does not aim to build a theory, but rather it seeks to illustrate through an exemplary analysis of a small but rich body of data, how an analysis of understanding dogs as mediating artifacts might be conducted.

It is now up to the reader to assess the context within which the results were found to hold, and to make decisions as to how they may apply to their situations in order to determine transferability. It is also up to the quantitative researcher to take these results and the way the experiences of the people in this study have been viewed and understood, and build instruments and scales for more extensive quantitative studies from which statistically generalisable conclusions may be drawn. The results of this study provide the quantitative researcher with a way to conceptualise what might be measured and how those instruments and scales may be constructed, how such a study might be conducted, and offer a framework to analyse and interpret the results.

The results of this study are also limited by environmental factors that included what may be interpreted as elements of oppression, power and control hierarchies operating in the classroom, aspects of the physical environment, and the establishment of rules regarding people's interaction with the dogs that may have moderated the effects reported in this study. Additionally, the time afforded by the duration of the course may have been a limitation in this study, and a longer period afforded by courses conducted over several months may have produced differing results. Further, the results of this study may be limited by the values, beliefs and

perceptions of regional Australian and Anglo-American cultures. Finally, the results may also be limited by people's orientation towards dogs, and their phobias and health concerns regarding their interaction with them. For example, people who viewed dogs as animals of utility, or who were indifferent towards interacting with them, reported that they experienced limited benefits. This may suggest that the inclusion of dogs in the adult classroom is not meaningful for everyone.

Lessons Learned

This research revealed several learnings in addition to answering the two research questions. These learnings arose from the researcher's use of the dogs as artifacts of research, and from the researcher's reflection on the methodological approach.

Learnings from the Researcher's Use of the Dogs as Artifacts

Implicit in both research questions is a focus on students. However, the discussion in the previous chapter suggests that *people* may also come to encompass not only students and the teacher, but the researcher as well. The use of the dogs as artifacts of research afforded the researcher the opportunity to explore aspects of teaching and learning beyond the research questions. This was achieved by using the dogs as objects of people's reflections that stimulated open discussion. This provided rich narratives of people's classroom experiences that may otherwise have remained unseen or unexamined.

Aspects of teaching and learning that were explored by using the dogs as artifacts included: the teacher—student divide and scoreboard focus; power and control hierarchies operating in the learning environment that gave rise to what may be interpreted as elements of oppression; professional praxis; and the hidden marginalised majority. The following précis of the principal meaning and

significance of these learnings may provide a deeper understanding of the context within which the results and conclusions of this research were found to hold, and therefore may assist the reader make their own decisions as to how the results may apply to their situations. They may also stimulate further discussion and debate on broader issues in Australian vocational education and training.

Teacher—Student Divide: Being Scoreboard Focused

The use of the dogs as objects of people's reflections drew attention to the divide between the teachers and students in this study. It is a gulf that appeared to be fostered by an imbalance between assessable outcomes and the students' social learning processes; processes that in this study were characterised by socialisation and established processes for effective group functioning. Nick Farr-Jones (2008), captain of the Wallabies World Cup Rugby team from 1988 to 1992, in a speech to business leaders, described such attention on outcomes as being scoreboard focussed. He emphasised the importance on being process driven, that is, focusing on "playing the game," understanding an individual's role, and trusting others to perform theirs. In the following excerpt from his speech, Farr-Jones explains that being focused on the scoreboard and outcomes shifts attention away from how to "play the game," and impedes an individual's and team's chances of success:

We made a million mistakes and we handed the game to this French team and we lost by about six points. We looked and analysed tapes and the mistakes that we made and what we actually came up with was, it wasn't complacency, it was actually desperation to win, and that was our problem. We were too desperate when we got the ball to get the scoreboard moving. We pushed passes. We wanted to score the try desperately, to get the scoreboard ticking, and to win the match. We were desperate to win. It

resulted in us basically forcing passes, throwing Cinderella balls, making mistakes, and handing the game to the opposition. That's being scoreboard focused, instead of focusing on what the process is. What we realised was we needed to change the culture of the Wallabies from a team that's desperate and scoreboard focused to a team that is more process driven. We became this hugely consistent team, and I put it down to that changing of the culture to understand what the process is.

The practitioners in this study appear to have been focused on the scoreboard of regulatory compliance and assessable outcomes. This was suggested by several students who reported that they felt the course was concerned with assessment rather than learning. It was also evidenced by the behaviour of the teachers in presenting assessment tasks as learning tasks, and frequently monitoring their completion. Consequently, these practitioners may have forgotten how to “play the game,” and understand their role in people's social learning processes, and the importance of trusting and helping others to perform theirs. Accordingly, they could have unknowingly hampered people's chances of learning success. This was suggested by several students who reported that they felt they achieved limited outcomes from the course apart from being able to state that they had obtained an accredited qualification. This suggests the value of further research to fully understand the nature and extent of this divide. Such research may have possible implications for policy makers in government to reconsider established frameworks for vocational education and training in Australia and could balance a focus on assessable outcomes and regulatory compliance with attention on people's learning processes, which are inherently social. This could help bridge the teacher—student

divide and assist practitioners to achieve genuine success in helping people realise their full learning potential.

Power & Control Hierarchies

The use of the dogs as objects of people's reflections also revealed the way power and control hierarchies appeared to operate at different levels in the learning environment to foster what may be interpreted as elements of oppression. For example, Sam revealed that Tanya appeared subordinate to the government and the registered training organisation on whose behalf she delivered the course. She also said that Tanya was focused on compliance with regulatory standards that had the potential to adversely affect her status as a training provider and, in turn, her continued revenue stream. Sam further described how she felt subordinate to Tanya, which limited the teaching methods and resources she could use, particularly the computers. She said that it also limited her control over the class and over the behaviour of the students. Similarly, several students expressed that they felt subordinate to the teachers and to Tanya, and felt they could not speak up or move freely around the room. They also described how they feared retribution from the teachers and acquiesced to their subordinate status as students. Borat summarised the functioning of power and control hierarchies by likening the classroom to a poker game and to acting, and said that people could not be themselves and had to play within the expectations of a particular character such as teacher, student or professional.

This suggests that the power and control hierarchies operating at different levels placed students in positions of powerlessness over what were intrinsically their own learning processes. Additionally, they may have situated the dogs as subordinate to all others, as Sharon suggested, and this may have factored in the

emotional climate in the classroom. For many students, this environment was characterised by anxiety, annoyance, disappointment, frustration, sufferance and unhappiness.

The learning environment in this study can be viewed as a rare example of what can occur in Australian vocational education and training settings. However, it may not be an isolated one. An exemplary classroom setting may have afforded different findings and conclusions. Yet the results of this study suggest that if dogs can be seen to function as artifacts by mediating people's learning processes amongst the most extreme setting, more significant results may be possible in settings with alternate power and control hierarchies. This points to the merit of further research to explore and understand the benefits of dog—human interaction in similar settings with different power structures and diverse emotional climactic conditions.

The use of the dogs as objects of people's reflections also revealed how the power and control hierarchies appear to have operated to foster what may be interpreted as elements of oppression that seemed to feature as a factor in people's interaction with the dogs. This was suggested by several students who described how they did not want to appear conspicuous by interacting with the dogs, and chose instead to use technology when they became bored or disinterested in the learning tasks. For several students this gave them the appearance of working when they were actually engaged in undesirable behaviours such as playing solitaire, checking email and looking up web sites. Students also appeared to use technology as an excuse to frequently leave the room. This was suggested by the repeated behaviour of students who left the room to retrieve documents that because of technical problems, printed outside the classroom. This seemed to give tacit

approval to people leaving the room for other reasons. Therefore, this research suggests implications for practitioners to consider how power and control hierarchies may foster distrust in the classroom and may encourage students to use artifacts in ways that are undesirable.

One of the interesting findings arising from this study was the way people appeared to use the dogs as vehicles to voice thoughts and concerns that conveyed latent messages. This holds the potential for practitioners to listen to these latent message and help students fight against their oppression. This is emphasised by Kordalewski (1999) who argues that students share in the construction of their knowledge only when their voices are heard. However, Freire (1972) points out that emancipation is principally the task of the oppressed learner who must be engaged to recognise and accept their oppression, and to work constructively to fight against it. This may point to the prospect for practitioners and policy makers in government to consider how they may help both teachers and learners to: recognise and accept their oppression; resituate the power and control hierarchies operating in the classroom; and to listen and respond to their latent voices. Freire (1972) suggests that this will allow teachers and learners to liberate both themselves and their oppressors, and thus help students realise their full learning potential.

Professional Praxis

The use of the dogs as objects of people's reflections also drew attention to issues of professional praxis. Established theories of adult learning such as those of Knowles (1980) and Brockett and Hiemstra (1991) are founded on a set of key assumptions. First, adult learners are self-directed and teachers should move students away from being teacher dependent. Second, adults bring a breadth and depth of life experiences to their learning. Additionally, the timing of learning

activities is related to developmental tasks and teachers should plan activities that are relevant and of interest to the learner at that time. Furthermore, adult learning is problem rather than subject centred. Finally, adults are internally rather than externally motivated to learn. However, in this study the teachers did not appear to fully apply these assumptions to their practice in the classroom. For example, students described the incongruity between the teaching techniques and their preferred learning styles, the lack of recognition of people's lived experiences, what appeared to them to be the illogical structure of the lessons, their reaction to cognitive load, the competence of the teachers, and the incongruity between the teachers' displayed skills and knowledge and what they were teaching. These comments were succinctly expressed by Coral who said, "this [the lesson] flies in the face of good practice."

Professional praxis was also evidenced by what Freire (1972) calls the banking concept of education, which he claims acts as a further instrument of oppression and results in the dehumanisation of both students and teachers. According to Freire (1972), this view of learning is framed as, "an act of depositing, in which the students are depositories and the teacher is the depositor" (p. 58). The practices that ignore professional praxis noted by Freire (1972) that were observed in this study included: the teacher teaching and the students being taught; the teacher positioned as the expert and the students seen as possessing little knowledge or experience; the teacher talking and the students listening; the teacher disciplining and the students being disciplined; the teacher making and enforcing decisions and choices and students complying with them; the teacher choosing the lesson content and delivery technique and the students, who were not consulted, adapting to it; and

the teacher positioned as the subject of the learning process while the students were seen as objects of learning.

These observations suggest the value of further research to fully understand the nature and extent of professional praxis. Such research may raise the prospect for policy makers in government to reconsider the experience and professional praxis of practitioners who are deemed competent to teach others how to teach. It may also have implications for them to reconsider the minimum standards of skills and the definitions of competence required for practitioners in Australian vocational education and training settings.

Hidden Marginalised Majority

The use of the dogs as objects of people's reflections during both the pilot and data collection, revealed participants who experienced alcoholism, domestic violence, drug dependencies, illicit drug use, adult literacy, teenage pregnancy, marital difficulties, learning difficulties, depression, anxiety, attempted suicide, attention deficit hyperactivity disorder, and physical impairments. It is sometimes easy and convenient for practitioners to conceive of adults in vocational education and training setting as fully functional. Yet this may not always be the case. This suggests that teachers may wish to consider being attentive and recognise that their class may include people from diverse circumstances, so that the needs of those people are not ignored and their learning not marginalised.

Additionally, it is possible that these groups can represent significant numbers in a class, and sometimes constitute the majority of students. This was suggested during the pilot for this research. During that class, over half of students stated that they had experienced, or were currently experiencing, at least one of the circumstances mentioned previously. During the data collection, this figure was just

under one-fifth. However, people who may not have been formally diagnosed, may not have been currently undergoing treatment, or who may not have acknowledged their situation, may have increased these numbers.

These observations suggest the value of further research to fully understand the scope and needs of people who are from diverse circumstances, so that practitioners can ease their marginalised status by adopting approaches to teaching that are inclusive. They may also have implications for practitioners to reconsider traditional conceptions of adults in vocational education and training settings as being fully functional, and to adopt approaches to teaching that are inclusive of the needs of people from diverse circumstances.

Learnings from Reflections on Methodology

A number of methodological lessons emerged during this study that may benefit future researchers. These lessons include logistics, the role of environment, the use and value of the repertory grid technique, the potential for longitudinal studies, and dog welfare and selection.

Logistics

Significant difficulties were experienced when attempting to establish contact with potential participants. Legislative privacy requirements meant that the training provider was unable to offer the researcher the names and contact details of potential participants without their prior consent. The researcher was thus reliant on the training provider to establish contact with people who had registered for the course, to send out research information packs that included consent to participate forms. He was also reliant on the training provider to encourage people to contact him, or provide consent to their contact details being released. However, staff changes and the end of year holiday period lead to communication breakdowns that

resulted in only one participant contacting the researcher prior to the commencement of the data collection.

This situation had several important impacts on the research. First, it was not possible to introduce the dogs to participants, outline the aims of the research and people's roles in the data collection, discuss questions or concerns they may have had, and gain their informed consent before the start of the course. Therefore the researcher negotiated with the teacher to gain time at the beginning of the course to address participants as a group. This posed the risk that if one or more participants did not provide their informed consent, then the data collection would need to be rescheduled for another suitable course. Yet addressing participants as a group may have placed the researcher in a position of authority, and may have influenced people's decision to participate. This position of authority may have been inferred by the way the researcher stood in the traditional teaching space at the front of the room with and introduced Adonis, after having been introduced as an accepted visitor ready to start collecting data. This may have influenced people's decision to participate, as they may have been unwilling to speak up and decline participation in front of a group of people they did not know, and may have felt it easier to submit to the view of the collective group.

It is recommended that future researchers work closely with the training provider and their staff to manage this situation by: clearly explaining the importance of their roles and what is expected of them; and by developing and articulating clear processes and protocols for establishing contact with potential participants, including contingency and mitigating actions. Future researchers may also benefit from integrating the issue and follow up of informed consent forms with the training provider's own processes and forms, particularly those for course

registration and payment.

The Role of Environment

The training facilities were occupied prior to the commencement of the course. This meant that the researcher was unable to conduct a site inspection prior to collecting data. Consequently, the researcher did not have the opportunity to influence the physical configuration of desks, chairs, equipment and cords, and was obliged to work within the constraints of the configuration determined by the training provider. The configuration of desks, chairs and equipment however, restricted people's easy access to the dogs, and meant that several students had difficulty seeing them. The configuration also posed potential safety risks arising from the dogs becoming entangled in cords and damaging electrical equipment, which could have caused injury. It also restricted the dogs' freedom of movement around the room and meant people sitting on one side of the room were unable to easily access them. This may have accounted for the dogs spending more time on one side of the room with one group of people. Only one request made by the researcher to modify the physical configuration was responded to when a table was placed in the middle of the arrangement of desks so that electrical cords could be kept away from the dogs' reach.

It is recommended that future researchers manage this situation by conducting a site inspection of the training facilities as early as possible. Additionally, it is recommended that future researchers negotiate with the training provider to configure the desks, chairs, equipment and cords to facilitate the dogs' safe, unencumbered and unrestricted movement around the room, and to facilitate people's easy access to and visibility of them.

Use and Value of the Repertory Grid Technique

The principal contribution of the repertory grid technique was to support the pattern of dynamics of social relationships within the classroom, and the social lens through which people viewed the learning environment. The repertory grid technique was also valuable in helping validate the way people used the dogs as artifacts by revealing constructs that described dichotomies of artifact use. It also proved a useful research tool by triggering discussion, dialogue and deep conversation that revealed rich qualitative data, which may otherwise have been difficult to obtain.

However, the low homogeneity of elements, that is, contrasting dogs with people, may have limited the potential to reveal more about the ways in which people interacted with the dogs and the meanings they derived from their use. Stewart and Stewart (1980) caution that elements should be carefully decided, and suggest that they be homogenous by avoid mixing classes of elements such as people with things, or things with activities. The repertory grid technique was piloted on several occasions to refine the range of elements used and method of attribute evaluation. However, achieving homogeneity across the elements proved difficult. Contrasting dogs with inanimate artifacts may have produced a similarly low homogeneity of elements. This difficulty highlights the challenge of considering living animals as artifacts, which are traditionally seen in the psychological or inanimate material form.

The difficulty of element selection when investigating dogs as artifacts may be overcome by providing a specific and clear focus to participants when contrasting elements, and by paying careful attention to the qualifying questions, such as, "In what ways are two of these the same that make them different from the

third, *with respect to what they mean to you as a learner,*” or “*...what they mean to your ability to concentrate,*” or, “*...with respect to what they mean to how you learn?*” Future researchers may also benefit from iteratively piloting the technique until the homogeneity of elements and qualifying questions produce constructs that are clearly within the target domain of the research questions.

The Potential for Longitudinal Studies

It was noted earlier that the findings of this study may have been limited by the time afforded by the duration of the course, and that a longer period afforded by courses conducted over several months may have produced differing results. This suggests the value of longitudinal studies to reveal further understandings of people’s use of dogs as artifacts gained over a longer period of time. However, Australian vocational education and training is not characterised by groups of the same people coming together on a regular basis over an extended period of time. Some courses are delivered in one or two half-days or full-days over several weeks. Other courses are delivered in one or two one-day sessions over several months. Additionally, the majority of vocational education and training courses are delivered in discrete groupings of competencies over short periods of time to different groups of people. When a defined set of competencies are completed, the person achieves the relevant qualification. However, different people often undertake different groupings of competencies and thus often do not share the same learning experience. This was evidenced in this study by Coral and Wade who attended for only the first three days of the course to complete the upgrade competencies. It was also evidenced by Morgan who already possessed several competencies and was therefore only required to attend five of the six and a half days.

Further, an emerging trend that has been noticeable in the researcher's professional practice during this research, is a continued drive for flexible, self-paced and computer-based learning. This trend sees the traditional classroom environment evolving into a collective laboratory environment with up to 40 students studying different subjects. In this paradigm, the teacher is positioned as a resource for those who experience difficulties or have questions. Conversely, this trend may suggest the value of further research to understand people's use of dogs as artifacts in changing contemporary training settings, and their influence on people's individualised processes of learning.

Dog Welfare and Selection

The importance of safeguarding the dogs' welfare is highlighted by Heimlich (2001) who reports that if left unmonitored, prolonged engagement can result in stress that may lead to debilitating and chronic conditions such as Cushing's syndrome¹⁷. It is therefore recommended that researchers pay careful attention to physical signs of stress that may include excessive panting and urination. This may have implications for future researchers in considering longitudinal studies where extended contact hours over longer periods of time may have adverse effects on the dogs. It is recommended that a number of dogs be used in these situations.

However, the dogs in this study appear to have experienced no adverse effects from the time spent interacting with people in the classroom. One of the

¹⁷ The medical term for Cushing's syndrome is hyperadrenocorticism. It is caused by excessive levels of cortisone in the blood brought about by chronic stress and requires lifetime medication (Tilley & Tilley, 2008).

reasons for this may have been the limited contact hours each dog spent in the classroom, which Heimlich (2001) suggests reduces fatigue and stress.

Nevertheless, Nicholls (2006) points out that the welfare of the dogs is paramount. Therefore, it is recommended that future researchers guard against complacency by educating students and teachers on the dogs' needs, their responsibilities for their welfare, and what is permissible when interacting with them.

This study used three dogs. This brought variety, which was welcomed by many people. This was suggested by students who described the different characteristics of each dog that they found appealing, and how their different behaviours and temperaments afforded different ways of interacting with them. However, not all dogs are suited to the classroom environment. Several students described how they would have liked to have brought their own dogs, however suggested that they were not of a suitable temperament. Nicholls (2006) suggests that dog selection is important, and that a suitable temperament is characterised by a dog who is not stressed by loud noises, crowded corridors or constant attention. She also suggests Delta standards as recommended, which were used in this research.

Additionally, this study revealed that enculturation of different breeds may be a factor in the way people perceive and interact with dogs. For example, German Shepherds and Pitt Bulls were seen as aggressive through their protective capacity associated with their roles in security, prisons, as guard dogs, and in the armed services. This contrasted with the way Labradors were seen as caring and nurturing. Therefore, when selecting dogs for inclusion in the classroom, it is recommended that future researchers consider the enculturation of the breed, and how the breed is perceived through its traditional roles in society.

Furthermore, participants in this study appeared to have strong preferences for Adonis and Buddy, both of whom were active, curious and initiating. For many people, Adonis and Buddy also displayed neotonistic physical and behavioural characteristics that rendered them puppy-like, which they found appealing. It is also recommended that future researchers consider these as preferred characteristics when selecting dogs for inclusion in the classroom.

Concluding Remarks

This research began with an examination of contemporary models of teaching and learning that characterise Australian vocational education and training settings. A divide appeared in these settings among teachers and students created by an imbalance between assessable outcomes and compliance, and students' processes of learning. To bridge this divide, this research adopted a sociocultural view, which emphasises the important role that artifacts play in learning.

Artifacts are traditionally thought of as either psychological or inanimate, material tools. This view was challenged by exploring the mediating role that dogs, functioning as artifacts, can play in helping people interact with and interpret the world around them. They appeared to do this by enhancing one group of people's learning cognitively, emotionally and socially and offered people with different preferences and style opportunities to meet their individual learning needs; and they did it wrapped up in one attractive, spontaneous package that was affordable, easy to use, and did not require specialist technical support. All they required was a responsible guardian, good grooming, a suitable temperament, and a researcher with an open mind and the courage to challenge established thinking.

Viewing our interactions with dogs through theories of personality and difference may lead to a greater understanding of the animal—human bond. It may

explain why some people are able to relate well to dogs and share rewarding relationships with them. It may also help explain why others experience difficulties and may help them to resolve those conflicts. In turn, this could lead to greater satisfaction in people's relationships with dogs, help people get the most from them, and further improve the quality of both human and animal life.

This research has opened the door for educators in all settings, to a framework for understanding the mediating role of dogs in people's processes of learning. Along the way, the dogs have provided pause for thought to critically reflect on professional practice, the role of the teacher in people's learning processes, and the nature of Australian vocational education and training.

BIBLIOGRAPHY

- Adams, R. (1977). *The plague dogs*. New York, NY: Fawcett.
- Aesop. (1989). *Aesop's fables*. New York, NY: Barron's Education Series.
- Ahmed, S. (2007). Islam's weakness is Islam. Retrieved 17 May, 2007, from <http://www.islamreview.com/articles/aslamsweakness.shtml>
- Alcock, J. (1972). The evolution of the use of tools by feeding animals. *Evolution*, 26, 464-473.
- Alfred, M. (2003). Sociocultural contexts and learning: Anglophone caribbean immigrant women in us postsecondary education. *Adult Education Quarterly*, 53(4), 242-260.
- Allen Consulting Group. (1994). *Successful reform: Competitive skills for Australia and Australian enterprises*. Melbourne, Victoria, Australia: Allen Consulting Group.
- Ammer, C. (1992). *The American heritage dictionary of idioms*. New York, NY: Houghton Mifflin.
- Anderson, G., & Arsenault, N. (2001). *Fundamentals of educational research*. London, England: Routledge Falmer.
- Anderson, W., Reid, P., & Jennings, G. (1992). Pet ownership and risk factors for cardiovascular disease. *Medical Journal of Australia*, 157, 298-301.
- Andrade, J. (2010). What does doodling do. *Applied Cognitive Psychology*, 24, 100-106.
- Anglin, G. J. (1991). *Instructional technology: Past, present and future*. Englewood, CO: Libraries Unlimited.
- Anonymous. (2003). Four-legged friends can help young learners in inclusive classrooms. *Inclusive Education Programs*, 10(2).

- Anton, M. M. (1996). Using ethnographic techniques in classroom observation: A study of success in foreign language class. *Foreign Language Annals*, 29(4), 551-561.
- Archer, J. (1997). Why do people love their pets? *Evolution and Human Behaviour*, 18, 237-259.
- Ascione, F. (1992). Enhancing children's attitudes about the humane treatment of animals: Generalization to human-directed empathy. *Anthrozoos*, 4, 226-247.
- Ascione, F. (2001). Animal abuse and youth violence: Juvenile justice bulletin, september, 2001. Retrieved 13 March, 2004, from http://www.ncjrs.org/html/ojjdp/jjbul2001_9_2/contents.html
- Ascione, F., & Weber, C. (1996). Children's attitudes about the humane treatment of animals and empathy: One-year follow up of a school-based intervention. *Anthrozoos*, 9(188-193).
- Atkinson, P., & Hammersley, M. (1994). Ethnography and participant observation. In N. K. Denzin & Y. S. Lincoln (Eds.), *Handbook of qualitative research*. Thousand Oaks, California: Sage Publications.
- Australian Bureau of Statistics. (2009). 2006 census. Retrieved 20 December, 2009, from <http://www.censusdata.abs.gov.au>
- Australian Chamber of Commerce & Industry. (2002). Employability skills: An employer perspective. Barton, Australian Capital Territory, Australia: Australian Chamber of Commerce & Industry.
- Australian Companion Animal Council. (2009). *The power of pets: The benefits of companion animal ownership*. Sydney, New South Wales, Australia: Australian Companion Animal Council Inc.

- Australian Qualifications Framework Advisory Board. (2007). *Australian qualifications framework: Implementation handbook (fourth edition, 2007)*. Carlton, Victoria, Australia: Australian Qualifications Framework Advisory Board.
- Baber, C. (2003). *Cognition and tool use: Forms of engagement in human and animal use of tools*. London, England: Taylor & Francis.
- Bacher, A., & Fromm, M. (2004). Gridsuite (version 2.0) [Computer software]. Stuttgart, Germany: Abit Solutions.
- Baker, K. (1987). Animals in the classroom: The debate continues. *Children and Animals, December-January*, 14.
- Balcombe, J. (2000). *The use of animals in higher education*. Washington, DC: Humane Society Press.
- Bandura, A. (1977). *Social learning theory*. New York, NY: General Learning Press.
- Bandura, A. (2001). Social cognitive theory: An agentic perspective. *Annual Review of Psychology*, 52, 1-26.
- Barbazette, J. (2006). *Training needs assessment methods, tools and techniques*. San Francisco, CA: Wiley.
- Bardill, N. (1997). Animal-assisted therapy with hospitalized adolescents. *Journal of Child and Adolescent Psychiatric Nursing*, 10(1), 17-24.
- Batson, K., McCabe, B., Baum, M., & Wilson, C. (1998). The effect of a therapy dog on socialization and physiological indicators of stress in persons diagnosed with alzheimer's disease. In D. Turner & C. Wilson (Eds.), *Companion animals in human health*. Thousand Oaks, CA: Sage Publications.

- Baumgartner, L. M. (2003). Transformative learning: Fundamental concepts. In L. M. Baumgartner, M. Lee, S. Birden & D. Flowers (Eds.), *Adult learning theory: A primer*. Ohio, OH: Ohio State University.
- Bayer, A. H., Brisbane, F. I., Ramirez, A., & Epstein, L. G. (1998). *Advanced methodological issues in culturally competent evaluation for substance abuse prevention*. Darby, PA: Diane Publishing.
- Bazeley, P., & Richards, L. (2006). *The nvivo qualitative project book*. London, England: Sage Publications.
- Beck, A., & Katcher, A. (1984). A new look at pet facilitated therapy. *Journal of the American Veterinary Medical Association*, 184, 414-421.
- Beck, A., Seraydarian, L., & Hunter, G. (1986). The use of animals in the rehabilitation of psychiatric inpatients. *Psychological Reports*, 8, 63-66.
- Beck, B. B. (1980). *Animal tool use behaviour: The use and manufacture of tools by animals*. New York, NY: Garland STMP Press.
- Belkin, L. (2001, 28 March). Four-legged distractions. *New York Times*, p. G1.
- Bell, R. (2006). A note on the correlation of elements in repertory grids: How to and why. *Journal of Constructivist Psychology*, 19(3), 273-279.
- Berger, J. (1980). Why look at animals? In J. Berger (Ed.), *About looking*. London, England: Writers and Readers.
- Bertaux, D. (1981). From the life=history approach to the transformation of sociological practice. In D. Bertaux (Ed.), *Biography and society: The life history approach in the social sciences*. London, England: Sage Publications.

- Bierer, R. (2000). *The relationship between pet bonding, self-esteem, and empathy in preadolescents*. (Doctoral dissertation, University of New Mexico, Albuquerque, NM, 2000). (UMI No. 9993506).
- Blake, R., & Mouton, J. (1985). *The managerial grid III: The key to leadership excellence*. Houston, TX: Gulf Publishing.
- The Body Corporate and Community Management Act(1997).
- Botaris, E. (2003). Looking back at 2003: Key trends in management development. Retrieved 23 March, 2004, from <http://www.mce.be>
- Bower, G. (1981). Mood and memory. *American Psychologist*, 32(2), 129-148.
- Boyd, R. D. (1989). Facilitating personal transformations in small groups: Part 1. *Small Group Behavior*, 20(4), 459-474.
- Bridges, D. (1997). Philosophy and educational research: A reconsideration of epistemological boundaries. *Cambridge Journal of Education*, 27(2), 177-188.
- Briggs-Myers, I. (1980). *Gifts differing: Understanding personality type*. Mountain View, CA: Davies-Black.
- British Columbia Society for the Prevention of Cruelty to Animals. (2004). Family violence and animal abuse: Public. Quebec, Canada: British Columbia Society for the Prevention of Cruelty to Animals.
- Brockett, R. (2004). Humanism as an instructional paradigm. In C. Dills & A. Romiszowski (Eds.), *Instructional development: State of the art paradigms in the field (volume 3)*. Englewood Cliffs, NJ: Educational Technology Publications.
- Brockett, R. G., & Hiemstra, R. (1991). *Self-direction in adult learning: Perspectives on theory, research and practice*. London, England: Routledge.

- Brofenbrenner, U. (1979). *The ecology of human development: Experiments by nature and design*. Cambridge, MA: Harvard University Press.
- Broido, E. M., & Manning, K. (2002). Philosophical foundations and current theoretical perspectives in qualitative research. *Journal of College Student Development, 43*(3), 434-445.
- Brookfield, S. D. (1993). Self-directed learning, political clarity and the critical practice of adult education. *Adult Education Quarterly, 43*(4), 227-242.
- Brookfield, S. D. (2000). Adult cognition as a dimension of lifelong learning. In J. Field & M. Leicester (Eds.), *Lifelong learning: Education across the lifespan*. London, England: RoutledgeFalmer.
- Bruner, J. (1985). Vygotsky: A historical and conceptual perspective. In J. Wertsch (Ed.), *Culture, communication and cognition: Vygotskian perspectives*. Cambridge, MA: Harvard University Press.
- Bruner, J., Wood, D., & Ross, G. (1976). The role of tutoring in problem solving. *Journal of Child Psychology and Psychiatry, 17*(2), 89-100.
- Bryant, B. (1985). *The neighborhood walk: A study of sources of support in middle childhood from the child's perspective*. Unpublished manuscript.
- Buckley, N. (1994). The magical number five: Towards a theory of everything? *Newsletter of the Board of Organisational Psychologists, Australian Psychological Society, February, 2994*, 1-27.
- Burgess, T. (1997). *Animal assisted therapy and the enhancement of mood in elderly nursing home residents*. (Doctoral dissertation, California State University, Long Beach, CA, 1997). (UMI No. 1385516).

- Burt, J. (2001). The illumination of the animal kingdom: The role of light and electricity in animal representation. *Society Animals: Journal of Human-Animal Studies*, 9(3), 203-228.
- Busato, V., Prins, F., Elshout, J., & Hamaker, C. (1999). The relation between learning styles, the big five personality traits and achievement motivation in higher education. *Personality and Individual Differences*, 26, 129-140.
- Byrne, M. (2001). Understanding life experiences through a phenomenological approach to research. *AORN Journal*, 73(4), 830-832.
- Byrne, R. (Writer). (2006). The secret [Motion picture]. In R. Byrne, P. Harrington & J. McAvoy (Producer). Hungary: TS Production LLC.
- Calder, J. (1993). *Disaffection and diversity: Overcoming barriers for adult learners*. London, England: Falmer.
- Caruth, D. (2000). *African American male transformative learning: An afrocentric study of the million-man march*. (Doctoral dissertation, University of Wyoming, Laramie, WY, 2000). (UMI No. 9982719).
- Cashin, W. E. (1985). *Improving lectures. Idea paper number 14*. Manhattan, NY: Kansas State University, Center for Faculty Evaluation and Development, Division of Continuing Education.
- Cattell, R. B. (1946). *The description and measurement of personality*. New York, NY: Harcourt, Brace and World.
- Charmaz, K. (2006). *Constructing grounded theory: A practical guide through qualitative analysis*. Thousand Oaks, CA: Sage Publications.
- Clark, D. (1995). Introduction to instructional systems design. Retrieved 7 November, 2004, from <http://www.nwlink.com/~donclark/hrd/sat1.html>

- Clark, M. C., & Wilson, A. L. (1991). Context and rationality in Mezirow's theory of transformational learning. *Adult Education Quarterly*, 41(2), 75-91.
- Cohen, J., & Leicester, M. (2000). The evolution of the learning society: Brain science, social science and lifelong learning. In J. Field & M. Leicester (Eds.), *Lifelong learning: Education across the lifespan*. London, England: RoutledgeFalmer.
- Coile, D. C. (2002). Bringing dog vision into focus. Retrieved 4 August, 2003, from <http://www.workingdogs.com>
- Cole, M. (1996). *Cultural psychology: A once and future discipline*. Cambridge, MA: Harvard University Press.
- Cole, M. (2005, 22 January). Kids face cruelty checks. *The Courier Mail*, p. 9.
- Collard, S., & Law, M. (1989). The limits of perspective transformation: A critique of Mezirow's theory. *Adult Education Quarterly*, 39(2), 99-107.
- Collins, C. (1993). *Competencies: For and against*. Paper presented at the Australian Curriculum Studies Association National Conference, Brisbane, Queensland, Australia.
- Colteryahn, K., & Davis, P. (2004). Trends you need to know now. *Training and Development*, January, 2004, 29-36.
- Coon, D., & Mitterer, J. (2010). *Introduction to psychology: Gateways to mind and behaviour*. Belmont, CA: Thompson Wadsworth.
- Coppinger, R., & Coppinger, L. (2001). *Dogs: A startling new understanding of canine origin, behaviour, and evolution*. New York, NY: Scribner.
- Cornford, I. (2004). Generic competencies: A review of some recent literature and analysis from an historical perspective. Sydney, New South Wales, Australia: University of Technology.

- Cottrell, R. R., & McKenzie, J. F. (2010). *Health promotion and education research methods: Using the five-chapter thesis/dissertation model*. Sudbury, MA: Jones and Bartlett Publishers.
- Cox, M., & Harris, A. (2003). *The significance and limitations of the vanth observation system within engineering classrooms*. Paper presented at the American Society for Engineering Education Annual Conference.
- Cranton, P. A. (2002). Teaching for transformation. In J. M. R. Gordon (Ed.), *Contemporary viewpoints on teaching adults effectively: New directions for adult and continuing education* (Vol. 93). San Francisco, CA: Jossey-Bass.
- Creagan, E. (2002). *A scientific look at the human-animal bond*. Atlanta, GA: PAWSitive InterAction.
- Creswell, J. (1998). *Qualitative inquiry and research design: Choosing among five traditions*. Thousand Oaks, CA: Sage Publications.
- Crowley-Robinson, P., Fenwick, D., & Blackshaw, J. (1996). A long-term study of elderly people in nursing homes with visiting and resident dogs. *Applied Animal Behaviour Science*, 47, 137-148.
- Cukan, A. (2002, 27 December). Animal tales: Pets boost human health. *United Press International* Retrieved 16 June, 2003, from http://www.upi.com/Science_News/2002/12/27/Animal-Tales-Pets-boost-human-health/UPI-72311041008636/
- Cummings, C. (2003). *Strategies for classroom management*. Alexandria, VA: Association for Supervision and Curriculum Development.
- Daloz, L. A. (1999). *Mentor: Guiding the journey of adult learners*. San Francisco, CA: Jossey-Bass.
- Daniels, H. (1996). *An introduction to Vygotsky*. London, England: Routledge.

- Darlington, R. (2008). Factor analysis. Retrieved 9 October, 2008, from <http://www.psych.cornell.edu/darlington/factor.htm>
- Dasey, D. (2003). Give that city dog a driza-bone. Retrieved 20 July, 2003, from <http://www.smh.com.au/articles/2003/07/18/1058035197346.html>
- Davis, K. A. (1992). Validity and reliability in qualitative research on second language acquisition and teaching: Another research comment. *TESOL Quarterly*, 26, 605-608.
- DeBord, K., & Thompson, A. (2004). Community diversity issues: Strategies for a comprehensive multicultural framework. Rockville, MD: Center for Substance Abuse Treatment, Substance Abuse and Mental Health Services Administration, United States Department of Health and Human Services.
- DeGrave, J. (1999). People and animals learning: The PAL program. In F. Ascione & P. Arkow (Eds.), *Child abuse, domestic violence and animal abuse: Linking the circles of compassion for prevention and intervention*. West Lafayette, IN: Purdue University Press.
- Deising, P. (1972). *Patterns of discovery in the social sciences*. New York, NY: Aldine.
- Delta Society Australia Ltd. (2004). *Annual report 2003-2004*. Sydney, New South Wales, Australia: Delta Society Australia.
- Department of Education Employment and Workplace Relations. (1999). *Employers' use and views on the VET system*. Canberra, Australian Capital Territory, Australia: Commonwealth of Australia.
- Department of Education Employment and Workplace Relations. (2007a). *Australian vocational education and training statistics 2007: Employers' use and view of the VET system*.

- Department of Education Employment and Workplace Relations. (2007b). *TAA04 training and assessment training package*.
- Department of Education Science and Training. (2003). *You can too: Adult learning in Australia: A consultation paper*. Canberra, Australian Capital Territory, Australia: Commonwealth of Australia, Department of Education, Science and Technology.
- Department of Education Science and Training. (2007a). *AQTF 2007 building training excellence: Essential standards for registration*.
- Department of Education Science and Training. (2007b). *AQTF 2007 building training excellence: Quality indicators handbook for registered training organisations*.
- Department of Education Science and Training. (2007c). *AQTF 2007 building training excellence: Standards for accredited courses*.
- Department of Education Science and Training. (2007d). *AQTF 2007 building training excellence: Standards for state and territory registering bodies*.
- Department of Education Science and Training. (2007e). *Training package development handbook*.
- Department of Education Training and the Arts. (2008). *Training packages at work back 2 basics edition 3: A guide to australia's vocational education and training system for teachers and trainers*.
- Dinsey, B. (2004). Instructors manual: Cairns City Kennel Club Obedience Section. Cairns City Kennel Club.
- Dirkx, J. M. (1998). Transformative learning theory in the practice of adult education: An overview. *PAACE Journal of Lifelong Learning*, 7, 1-14.

- Divahran, S., & Ping, L. (2002). *A collective case study of it integration in Singapore secondary schools*. Paper presented at the International Education Research Conference, 2-6 December, 2001, Fremantle, Western Australia, Australia.
- Doyle, W. (2006). Ecological approaches to classroom management. In C. M. Evertson & C. S. Weinstein (Eds.), *Handbook of classroom management: Research, practice and contemporary issues*. Mahwah, NJ: Lawrence Erlbaum.
- Draper, R. (1990). Defining the role of pet animals in psychotherapy. *Psychiatric Journal of the University of Ottawa*, 15(3), 169-172.
- Drummond, R. J., & Stoddard, A. H. (1992). Learning style and personality type. *Perceptual and Motor Skills*, 75, 99-104.
- Duruz, A. (2007). *Workforce development: Introducing the national skills framework*.
- Easterby-Smith, M., Thorpe, R., & Holman, D. (1996). Using repertory grids in management. *Journal of European Industrial Training*, 20(3), 3-30.
- Easton, V. J., & McColl, J. H. (2010). Steps statistics glossary. Retrieved 12 January, 2010, from <http://www.stats.gla.ac.uk>
- Edney, A. (1992). Companion animals and human health: An overview. *Journal of the Royal Society of Medicine*, 88, 704-708.
- Edwards, R. A., Sieminski, S., & Zeldin, D. (1993). *Adult learners, education and training*. London, England: Routledge.
- Emmer, E. T., & Stough, L. M. (2001). Classroom management: A critical part of educational psychology with implications for teacher education. *Educational Psychologist*, 36, 103-112.

- Engestrom, Y. (1987). *Learning by expanding: An activity-theoretical approach to developmental research*. Helsinki, Finland: Orienta-Konsultit Oy.
- Englebart, D. C. (1963). A conceptual framework for the augmentation of man's intellect. In H. Weeks (Ed.), *Vistas in information handling volume 1*. New York, NY: Spartan Books.
- Eriksson, T., Lindahl, B., & Bergbom, I. (2010). Visits in an intensive care unit: An observational hermeneutic study. *Intensive and Critical Care Nursing*, 26(1), 51-57.
- Evans, J. (2000). *Adults' mathematical thinking and emotions*. London, England: RoutledgeFalmer.
- Eysenck, H. J. (1978). The development of personality and its relation to learning. In S. Murray-Smith (Ed.), *Melbourne studies in education*. Melbourne, Victoria, Australia: Melbourne University Press.
- Farr-Jones, N. (2008). *Breakfast with inspiring leaders*. Paper presented at the Macmahon Construction Leadership Breakfast.
- Fawcett, N. R., & Gullone, E. (2001). Cute and cuddly and a whole lot more? A call for empirical investigation into the therapeutic benefits of human-animal interaction for children. *Behaviour Change*, 18(2), 124.
- Fédération Cynologique Internationale. (2004). For dogs worldwide. Retrieved 11 October, 2004, from <http://www.fci.be>
- Feixas, G., & Alvarez, J. M. C. (2006). *A manual for the repertory grid using the Gridcor programme*. Barcelona, Spain: Asociacion Espanolade Psicoterapias Cognitivas.

- Feldman, M., Skildbert, K., Brown, R., & Horner, D. (2004). Making sense of stories: A rhetorical approach to narrative analysis. *Journal of Public Administration Research and Theory, 14*(2), 147-170.
- Flowers, D. (2003). An afrocentric view of adult learning theory. In L. M. Baumgartner (Ed.), *Adult learning theory: A primer*. Columbus, OH: College of Education, The Ohio State University.
- Fogelman, D., & Williams, C. (Writer). (2008). Bolt [Motion picture]. In J. Lasseter & C. Spencer (Producer). United States: Buena Vista Pictures.
- Foulger, D. (1977). A theory of distraction. From the hypermedia edition of Foulger, Davis A. (1977). *Distraction and dissonance: A model of the persuasive process*. Master's thesis university of central florida. Retrieved 25 October, 2008, from <http://foulger.info/davis/mastersThesis/chapter2.htm>
- Fransella, F., & Bannister, D. (1977). *A manual for repertory grid technique*. London, England: Academic Press.
- Freire, P. (1972). *Pedagogy of the oppressed*. London, England: Penguin.
- Friedmann, E., Katcher, A., Lynch, J., & Thomas, S. (1980). Animal companions and one-year survival of patients after discharge from a coronary unit. *Public Health Reports, 95*, 307-312.
- Friedmann, E., & Thomas, S. (1995). Pet ownership, social support, and one-year survival after acute myocardial infarction in the cardiac arrhythmia suppression trial (CAST). *American Journal of Cardiology, 76*, 1213-1217.
- Furnham, A. (1992). Personality and learning style: A study of three instruments. *Personality and Individual Differences, 13*(4), 429-438.
- Gagne, R. (1985). *The conditions of learning and theory of instruction*. New York, NY: Rinehart and Winston.

- Gaita, R. (2002). *The philosopher's dog*. Melbourne, Victoria, Australia: The Text Publishing Company.
- Gammack, J., & Stephens, R. (1994). Repertory grid technique in constructive interaction. In C. Cassell & G. Symon (Eds.), *Qualitative methods in organisational research*. London, England: Sage Publications.
- Garrity, T., & Stallone, L. (1998). Effects of pet contact on human well-being: Review of recent research. In C. Wilson & D. Turner (Eds.), *Companion animals in human health*. Thousand Oaks, CA: Sage Publications.
- Garson, G. D. (2008). Factor analysis. Retrieved 9 October, 2008, from <http://faculty.chass.ncsu.edu/garson/PA765/factor.htm>
- Gee, J. P. (1992). *The social mind: Language, ideology, and social practice*. New York, NY: Bergin & Garvey.
- Gee, J. P., Hull, G., & Lankshear, C. (1996). *The new work order: Behind the language of the new capitalism*. Sydney, New South Wales, Australia: Allen and Unwin.
- German Shepherd Dog Association of Western Australia. (2010). About the German Shepherd dog association of Western Australia. Retrieved 2 February, 2010, from <http://www.gsdawa.org/AbtGSDA.html>
- Gibson, J. J. (1966). *The senses considered as perceptual systems*. Boston, MA: Houghton Mifflin.
- Glaser, B., & Strauss, A. (1967). *The discovery of grounded theory*. Chicago, IL: Aldine.
- Goetz, J. P., & LeCompte, M. D. (1981). Ethnographic research and the problem of data reduction. *Anthropology and Education Quarterly*, 12(1), 51-70.

- Gold, R. (1958). Roles in sociological field observation. *Social Forces*, 36(3), 217-223.
- Goodwin, J. (1999). The benefits of pets in the classroom. Unpublished Paper.
- Gordeeva, T. (2009). German sheperd: The ultimate service dog. Retrieved 2 February, 2010, from http://www.germanculture.com.ua/library/weekly/german_shepherds.htm
- Gough, H. G. (1957). *Manual for the California Psychological Inventory*. Moutain View, CA: CPP Inc.
- Grace, A. P. (1996). Striking a critical pose: Andragogy - missing links, missing values. *International Journal of Lifelong Education*, 15(5), 382-392.
- Granger, B. P., & Granger, G. V. (2003). Voluntary association development and the human-animal bond. Retrieved 10 July, 2003, from <http://www.friends-partners.org/oldfriends/education/audem93/granger.html>
- Grice, J. (2007). Idiogrid (version 2.4) [Computer software]. Silverwater, OK: Oklahoma State University.
- Grice, J. W. (2003). *Idiogrid manual: Idiographic analysis with repertory grids*. Stillwater, OH: Oklahoma State University.
- Griffin, S. (2003). Animal-assisted learning: Maximizing the natural bond between children and animals. Retrieved 10 July, 2003, from <http://www.realsolutions.org>
- Grogan, J. (2006). *Marley and me*. Melbourne, Victoria, Australia: Hodder.
- Grusec, J. E., & Hastings, P. D. (2007). *Handbook of socialization: Theory and research*. New York, NY: Guilford Press.
- Grzywacz, J., & Fuqua, J. (2000). The social ecology of health: Leverage points and linkages. *Behavioural Medicine*, 26, 101-115.

- Guba, E., & Lincoln, Y. (1989). *Fourth generation evaluation*. Newbury Park, CA: Sage Publications.
- Guest, G., Bunce, A., & Johnson, L. (2006). How many interviews are enough? An experiment with data saturation and variability. *Field Methods*, 18(1), 59-82.
- Guribye, F. (1999). *Evaluating a collaborative telelearning scenario: A sociocultural perspective*. Unpublished candidatus rerum politicarum thesis. Department of Information Science, University of Bergen, Bergen, Norway.
- Guribye, F. (2003). *Infrastructures for learning: Ethnographic inquiries into the social and technical conditions of education and training*. Paper presented at the Nail Extended - Nettverk for Analyse av Interaksjon og læring, Forskningsparken As, Oslo, Norway.
- Haig, B. D. (1995). Grounded theory as scientific method. Retrieved 2 December, 2005, from http://www.ed.uiuc.edu/EPS/PES-yearbook/95_docs/haig.html
- Hanson, A. (1996). The search for a separate theory of adult learning: Does anyone really need andragogy? In R. Edwards, A. Hanson & P. Raggatt (Eds.), *Boundaries of adult learning*. London, England: Routledge.
- Hare, B., Brown, M., Williamson, C., & Tomasello, M. (2002). Domestication of social cognition in dogs. *Science*, 298, 1634-1636.
- Harris, R., Simons, M., & McCarthy, C. (2006). *Private trianing providers in Australia: Their characteristics and training activities*. Adelaide, South Australia, Australia: National Centre for Vocational Education Research.
- Harrow, A. J. (1972). *A taxonomy of the psychomotor domain*. New York, NY: David McKay.
- Hart, L., Hart, B., & Bergin, B. (1987). Socialising effects of service dogs for people with disabilities. *Anthrozoos*, 1, 41-44.

- Hashway, R. (1998). *Developmental cognitive styles: A primer to the literature including an introduction to the theory of developmentalism*. San Francisco, CA: Austin and Winfield Publishers.
- Hastings, R. P., & Bham, M. S. (2003). The relationship between student behavior patterns and teacher burnout. *School Psychology International*, 24(115-127).
- Hathaway, W. E. (1988). Educational facilities: Neutral with respect to learning and human performance. *CEFPI Journal*, 26(4), 8-12.
- Headey, B. (2006). *National people and pets survey, socially responsible pet ownership in Australia: A decade of progress*. Melbourne, Victoria, Australia: Melbourne Institute of Applied Economic and Social Research, University of Melbourne.
- Heimlich, K. (2001). Animal-assisted therapy and the severely disabled child: A quantitative study. *Journal of Rehabilitation*, 67(4), 48-54.
- Helmke, A. (1986). Student attention during instruction and achievement. In S. E. Newstead, S. H. Irvine & P. L. Dann (Eds.), *Human assessment: Cognition and motivation*. Dordrecht, The Netherlands: Nijhoff.
- Henderson, K. (1997). *Moral reasoning, empathy, and behaviour of students with and without emotional and behavioural disorders and learning disabilities: Impact of a structured program of experiential learning activities involving animals and nature*. (Doctoral dissertation, University of Maryland, College Park, MA, 1997). (UMI No. 9816470).
- Hendrickson, P. (1999). Going to the dogs. *Incentive*, 173(9), 143-150.
- Hersey, P., Blanchard, K., & Johnson, D. (1988). *Management of organizational behaviour: Leading human resources*. Englewood Cliffs, NJ: Prentice Hall.

- Higgins, A. T., & Turnure, J. E. (1984). Distractibility of attention in children's development. *Child Development*, 55, 1799-1810.
- Hochschild, A. (1997). *The time bind: When work becomes home and home becomes work*. New York, NY: Metropolitan Books.
- Holloway, I. (1997). *Basic concepts for qualitative research*. Oxford, England: Blackwell Science.
- Honey, P., & Mumford, A. (1982). *The manual of learning styles*. Maidenhead, England: Honey Press.
- Hu, K. (2004). Dogs in the psychology classroom. Retrieved 13 March, 2004, from <http://fog.ccsf.edu/~khu/compsych.html>
- Hvitfeldt, C. (1986). Traditional culture, perceptual style and learning: The classroom behavior of Hmong adults. *Adult Education Quarterly*, 36(2), 65-77.
- Hyland, T. (1997). *Teaching, learning and nvqs: Challenging behaviourism and competence in adult education theory and practice*. Paper presented at the 1997 International SCUTREA Conference, Royal Holloway, University of London, England.
- Isaacs, G. (1996). Bloom's taxonomy of educational objectives. Brisbane, Queensland, Australia: Teaching & Learning Institute, The University of Queensland.
- Ivarson, J. (2003). *Renderings and reasonings: Artifacts, cognition and human knowing*. Paper presented at the NAII Extended - Nettverk for Analyse Av Interaksjon og Laering, Forskningsparken, Oslo, Norway.
- Jackson, N. (1993). Competence: A game of smokes and mirrors. In C. Collins (Ed.), *Competencies: The competencies debate in austgralian education and*

training. Canberra, Australian Capital Territory, Australia: Australian College of Education.

- Jacobs, G. (2004). Extending the circle of compassion to include nonhuman animals: The case of the use of who in dictionaries, works on grammar, and publication manuals and by newspaper and newsagencies. Retrieved 17 September, 2010, from <http://www.ecoling.net.whowhat.pdf>
- Jankowicz, A. D. (1990). Applications of personal construct psychology in business practice. *Advances in Personal Construct Psychology*, 1(257-287).
- Jarvis, P. (1987). *Adult learning in the social context*. London, England: Croom Helm.
- Jarvis, P. (1992). *Paradoxes of learning*. San Francisco, CA: Jossey-Bass.
- Jasinski, M. (1996). *Teaching and learning the key competencies in vocational education and training: Project report*. Adelaide, South Australia, Australia: Douglas Mawson Institute of TAFE, Department for Employment, Training and Further Education, South Australia.
- John-Steiner, V., & Mahn, H. (1996). Sociocultural approaches to learning and development: A Vygostkian framework. *Educational psychologist*, 31, 191-206.
- Johnson, G. (2002). The pattern of violence. *Animal Sense, Fall/Winter 2002*.
- Johnson, J. (2001). *Domestic violence and animal abuse*. Paper presented at the Seeking Solutions.
- Johnstone, A. H., & Percival, F. (1976). Attention breaks in lectures. *Education in Chemistry*, 13(49-50).
- Jones, W. K. (1943). Must we use idioms? *Hispania*, 26(1), 65-68.

- Kafka, F. (1977). Investigations of a dog. In F. Kafka (Ed.), *Selected short stories of frank kafka*. New York, NY: Random House.
- Kalnins, I., Hart, C., Ballantyne, P., Quartaro, G., Love, R., Struris, G., et al. (2002). Children's perceptions of strategies for resolving community health problems. *Health Promotion International, 17*(3), 223-233.
- Katcher, A., Friedman, E., Beck, A., & Lynch, J. (1983). Looking, talking, and blood pressure, the physiological consequences of interaction with the living environment. In A. Katcher & A. Beck (Eds.), *New perspectives on our lives with companion animals*. Philadelphia, PA: University of Pennsylvania Press.
- Katcher, A., & Wilkins, G. (1994). *The use of animal assisted therapy and education with attention deficit hyperactive and conduct disorders*. Paper presented at the 14th Annual Delta Society Conference, New York, NY.
- Kearsley, G. (2004). Explorations in learning and instruction. Retrieved 11 October, 2004, from <http://tip.psychology.org>
- Keeley, B. (2004). Anthropomorphism, primatomorphism, mammalomorphism: Understanding cross-species comparisons. *Biology and Philosophy, 19*, 521-540.
- Kegan, R. (2000). What form transforms? In J. Mezirow (Ed.), *Learning as transformation: Critical perspectives on a theory in progress*. San Francisco, CA: Josey-Bass.
- Keirsley, D. (1978). *Please understand me II: Temperament, character, intelligence*. Del Mar, CA: Prometheus Nemesis Book Company.

- Kellert, S. R., & Berry, J. K. (1980). *Phase III: Knowledge, affection and basic attitudes towards animals in American society*. Washington, DC: United States Government Printing Office.
- Kelly, G. (1955). *The psychology of personal constructs*. New York, NY: Norton.
- Kidd, A., & Kidd, R. (1980). Personality characteristics and preferences in pet ownership. *Psychological Reports*, 46, 939-949.
- Kin, C. C. (2005, 13 September). Two charged with making racist remarks on the net. *The Straits Times*, p. 1.
- Kincheloe, J. (2003). *Teachers as researchers: Qualitative inquiry as a path to empowerment*. New York, NY: RoutledgeFalmer.
- Knowles, M. (1980). *The modern practice of adult education: From pedagogy to andragogy*. Englewood Cliffs, NJ: Prentice Hall.
- Knowles, M. (1990). *The adult learner: A neglected species*. Houston, TX: Gulf Publishing.
- Kolb, D. A. (1984). *Experiential learning: Experience as the source of learning and development*. Englewood Cliffs, NJ: Prentice Hall.
- Kordalewski, J. (1999). Incorporating student voice into teaching practice. Washington, DC: ERIC Digest, ERIC Clearinghouse on Teaching and Teacher Education (ED440049).
- Koschmann, T. (1994). Towards a theory of computer-support for collaborative learning. *Journal of the Learning Sciences*, 3, 218-224.
- Koschmann, T. (1996). Paradigm shifts and instructional technology: An introduction. Retrieved 3 December, 2004, from http://dwebct.lanet.lv/doc/koschmanns_paradigm.pdf

- Kotrschal, K., & Ortbauer, B. (2003). Behavioural effects of the presence of dogs in a classroom. *Anthrozoos*, 16(2), 147-159.
- Krathwohl, D. (2004). *Methods of educational and social science research: An integrated approach*. Long Grove, Illinois: Waveland Press.
- Kusuma-Powell, O., & Powell, W. (2005). *Count me in: Developing inclusive international schools*. Washington, DC: Overseas Schools Advisory Council, USA Department of State.
- Kvale, S. (1996). *Interviews: An introduction to qualitative research interviewing*. Thousand Oaks, California: Sage Publications.
- LaBianco, A., & Bushell, J. (Writer). (2008). Beverly Hills Chihuahua [Motion picture]. In D. Hoberman, J. Jacobs & T. Lieberman (Producer). United States: Buena Vista Pictures.
- Lacoff, S. (1999). *Boris M. Levinson a historial perspective: A focus on his work involving animal assisted psychotherapy*. (Doctoral dissertation, Miami Institute of Psychology, Miami, FL, 1999). (UMI No. 9975620).
- Lacy, A., & Luff, D. (2001). *An introduction to qualitative data analysis*. Nottingham, England: Trent Focus for Research and Development in Primary Health Care.
- Latour, B. (1992). Where are the missing masses? The sociology of a few mundane artifacts. In W. Bijker & J. Law (Eds.), *Shaping technology/building society - studies in sociotechnical change*. Cambridge, MA: MIT Press.
- Latour, B. (1996). *Aramis, or the love of technology*. Cambridge, MA: Harvard University Press.
- Lave, J. (1988). *Cognition in practice: Mind, mathematics and culture in everyday life*. Cambridge, MA: Cambridge University Press.

- Lave, J., & Wenger, E. (1991). *Situated learning: Legitimate peripheral participation*. Cambridge, MA: Cambridge University Press.
- Lawrence, E. (2005, 6 February). It's our worst year for animal cruelty. *The Sunday Mail*, p. 21.
- Le Doux, J. (1996). *The emotional brain: The mysterious underpinnings of emotional life*. New York, NY: Simon and Schuster.
- Le Page, K. (2010). What are distraction techniques in CBT? Retrieved 5 July, 2010, from <http://cognitive-psychology.suite101.com/article.cfm/what-are-distraction-techniques>
- Lee, D., Woo, J., & Mckenzie, A. (2002). The cultural context of adjusting to nursing home life: Chinese elders' perspective. *The Gerontologist*, 42(5), 667-675.
- Lee, M. (1999). *The role of cultural values in the interpretation of significant life experiences*. Paper presented at the The 40th Annual Adult Education Research Conference, DeKalb, IL.
- Lee, M. (2003). A critical analysis of andragogy: The perspectives of foreign-born adult learners. In L. M. Baumgartner (Ed.), *Adult learning theory: A primer*. Columbus, OH: College of Education, The Ohio State University.
- Leigh, D. (2004). A brief history of instructional design. Retrieved 3 December, 2004, from <http://www.pignc-isp.com/articles/education/brief%20history.htm>
- Leung, C. C. (2006, 20 February). Once students would hound a teacher's pet: Now they're happy to be part of the pack. *The Age*, p. 3.
- Levinson, B. (1969). *Pet-oriented child psychotherapy*. Springfield, Illinois: Charles C. Thomas.

- Lewis, F. E. (1977). *The influence of open-space classrooms and closed-space classrooms on teachers' attitudes towards the school building*. Unpublished doctoral dissertation, University of Georgia, Athens, GA.
- Lieber, J. (2002). *Animal-assisted therapy for elementary students with emotional or behavioural disorders*. (Doctoral dissertation, University of Northern Colorado, Greeley, CO, 2002). (UMI No. 3056665).
- Lincoln, Y. S., & Guba, E. G. (1985). *Naturalistic inquiry*. Thousand Oaks, CA: Sage Publications.
- Lockwood, R. (1983). The influence of animals on social perceptions. In A. Katcher & A. Beck (Eds.), *New perspectives on our lives with companion animals*. Philadelphia, PA: University of Pennsylvania Press.
- Lockwood, R., & Church, A. (1996). Deadly serious: An FBI perspective on animal cruelty. *HSUS News*(Fall), 27-30.
- Lofland, J., & Lofland, L. H. (1984). *Analyzing social settings: A guide to qualitative observation and analysis*. Belmont, CA: Wadsworth.
- Luft, J. (1984). *Group process: An introduction to group dynamics*. Mountain View, CA: Mayfield Publishing.
- Mager, R. (1975). *Preparing instructional objectives*. Belmont, CA: Lake Publishing Co.
- Malamud, R. (2003). How people and animals coexist. *The Chronical of Higher Education*, 49(20), B7-B9.
- Mallon, G. (1994). Some of our best therapists are dogs. *Child and Youth Care Forum*, 23(2), 89-101.
- Mandler, G. (1984). *Mind and body*. New York, NY: Norton.

- Mantell, S. (2003). Puppies and horses and cats, oh my! *Publishers Weekly*, 250(14), 32-37.
- Marcano, R. L. (2001). Through the eyes of a latina: Professional women in adult education. In V. Sheared & P. Sissel (Eds.), *Making space: Merging theory and practice in adult education*. Westport, CT: Bergin & Garvey.
- Marshall, C., & Rossman, G. B. (1999). *Designing qualitative research*. London, England: Sage Publications.
- Marston, W. (1979). *The emotions of normal people*. Minneapolis, MN: Personal Press.
- Martikainen, P., Bartley, M., & Lahelma, E. (2002). Psychosocial determinants of health in social epidemiology. *International Journal of Epidemiology*, 31(6), 1091-1093.
- Marvin, G. (2001). Cultured killers: Creating and representing foxhounds. *Society and Animals*, 9(3), 273-292.
- Mason, M. (2010). Sample size and saturation in PhD studies using qualitative interviews. *Forum: qualitative sozialforschung*. Retrieved 11 October, 2010, from <http://www.qualitative-research.net/index.php/fqs/artcle/viewArticle/1428/3027>
- Masson, J. (1998). *Dogs never lie about love*. London, England: Random House.
- Mathews, S., & Herzog, H. (1997). Personality and attitudes towards the treatment of animals. *Society and Animals*, 5(2), 169-175.
- Matthews, P. (1999). Workplace learning: Developing a holistic model. *Learning Organisation*, 6(1), 18-29.
- Maxwell, J. A. (1996). *Qualitative research design: An integrative approach*. Thousand Oaks, CA: Sage.

- McCrae, R., & Costa, P. (1989). Reinterpreting the Myers-Briggs Type Indicator from the perspective of the five-factor model of personality. *Journal of Personality, 57*(1), 17-40.
- McCrae, R. R., & John, O. P. (1992). An introduction to the five-factor model and its applications. *Journal of Personality, 60*, 175-213.
- McCrindle, M. (2009). *Bridging the gap: Generational diversity at work*. Sydney, New South Wales, Australia: McCrindle Research.
- McIntosh, S. C. (2001). The links between animal abuse and family violence as reported by women entering shelters in calgary communities. *Equine Facilitated Counselling*.
- McKay, R. (2001). Getting close to animals with Alice Walker's 'The Temple of My Familiar'. *Society Animals: Journal of Human-Animal Studies, 9*(3).
- McKnight, C. (2000). The personal construction of information space. *Journal of the American Society for Information Science, 51*(8), 730-733.
- McLaughlin, C. R. (2003). Furry friends can help your health. Retrieved 10 July, 2003, from <http://health.howstuffworks.com/wellness/aging/furry-friends-can-aid-your-health.htm>
- McMurtry, A. (2004). Complexity and education. Retrieved 7 November, 2004, from http://www.complexityandeducation.ualberta.ca/glossary/g_modernism.htm
- McNamara, C. (1999). General guidelines for conducting interviews. Retrieved 8 August, 2005, from <http://208.42.83.77/evaluati/intrview.htm>
- Melson, G. (1989). Studying children's attachment to their pets: A conceptual and methodological review. *Anthrozoos, 4*(2), 91-99.

- Mendoza, S. (1985). The exchange grid. In N. Beail (Ed.), *Repertory grid technique and personal constructs: Applications in clinical and education settings*. Canberra, Australian Capital Territory, Australia: Croom Helm.
- Merrill, M. D., Lin, Z., & Jones, M. K. (1990). Second generation instructional design. *Educational Technology and Society*, 36(2), 7-14.
- Merritt, R., & Barth, M. (2000). *A thousand hounds*. Köln, Germany: Taschen.
- Messent, P. (1983). A review of recent developments in human-companion animal studies. *California Veterinarian*, 5, 26-50.
- Messent, P., & Serpell, J. (1981). An historial and biological view of the pet-owner bond. In B. Fogle (Ed.), *Interrelations between people and pets*. Springfield, IL: Charles C. Thomas.
- Mezirow, J. (2000). Learning to think like an adult: Core concepts of transformation theory. In J. Mezirow (Ed.), *Learning as transformation: Critical perspectives on a theory in progress*. San Francisco, CA: Jossey-Bass.
- Middendorf, J., & Kalish, A. (1996). The change-up in lectures. *The National Teaching and Learning Forum*, 5(2), 1-5.
- Miles, M. B., & Huberman, A. M. (1994). *Qualitative data analysis*. Thousand Oaks, CA: Sage Publications.
- Miller, J., Connor, C., Deal, B., Duke, G. W., Stanley-Hermanns, M., Varnell, G., et al. (2003). How animal-assisted therapy affects discharge teaching: A pilot study. *Critical Care Choices*, 36-40.
- Mills, C. W. (1959). On intellectual craftsmanship. In C. W. Mills (Ed.), *The sociological imagination*. London, England: Oxford University Press.
- Modlin, S. J. (2000). Service dogs as interventions: State of the science. *Rehabilitation Nursing*, 25(6), 212.

- Morse, J. (1994). Designing funded qualitative research. In N. Denzin & Y. Lincoln (Eds.), *Handbook of qualitative research*. Thousand Oaks, CA: Sage Publications.
- Morse, J. M., & Field, P. A. (1995). *Qualitative research methods for health professionals*. Thousand Oaks, CA: Sage Publications.
- Mortkowitz, L. (2010, April 25). More colleges, professors shutting down laptops and other digital distractions. Retrieved 29 June, 2010, from <http://www.washingtonpost.com/wp-dyn/content/article/2010/04/24/AR2010042402830.html>
- Motulsky, H. (1999). *Analyzing data with graphpad prism*. San Diego, CA: GraphPad Software.
- Murtaugh, M. (1985). The practice of arithmetic by American grocery shoppers. *Anthropology and Education Quarterly*(16), 186-192.
- Myers, G. (1998). *Children and animals: Social development and our connections to other specials*. Boulder, CO: Westview Press.
- Naoi, T., Airey, D., Iijima, S., & Niininen, O. (2006). Visitor's evaluation of an historic district: Repertory grid analysis and laddering analysis with photographs. *Tourism Management*, 27, 420-436.
- Nathanson, D. (1998). Long term effectiveness of dolphin-assisted therapy for children with severe disabilities. *Anthrozoos*, 1(1), 22-32.
- National Society for Humane and Environmental Education. (2005). Classroom management and the teacher's pet. Retrieved 25 November, 2005, from http://www.nahee.org/research_evaluation/PDF?KT-2004.pdf
- Neimeyer, R. A., & Neimeyer, G. J. (2002). *Advances in personal construct psychology*. New York, NY: Praeger.

- Netting, F., Wilson, C., & New, J. (1987). The human-animal bond: Implications for practice. *Social Work, 32*(1), 60-64.
- Newby, J. (1999). *The animal attraction: Humans and their animal companions*. Sydney, New South Wales, Australia: ABC Books.
- Newby, J. (2001). The animal attraction. Retrieved 12 July, 2003, from <http://www.abc.net.au/animals>
- Nicholls, B. (2006). Class act! *The National Education Magazine, May, 2006*, 27-29.
- Norman, D. (1988). *The psychology of everyday things*. New York, NY: Harper Collins.
- Norman, J. (2000). Techniques of analysis: The repertory grid. Retrieved 26 August, 2006, from <http://www.gowertraining.co.uk/docs/repgrid.pdf>
- Nunes, T., Schliemann, A. D., & Carraher, D. W. (1993). *Street mathematics and school mathematics*. Cambridge, MA: Cambridge University Press.
- O'Farrell, V. (1997). Owner attitudes and dog behaviour problems. *Applied Animal Behaviour Science, 52*, 205-213.
- Ormond, J. E. (1999). *Human learning*. Upper Saddle River, NJ: Prentice-Hall.
- Orwell, G. (1945). *Animal farm*. London, England: Secker and Warburg.
- Orwell, G., Jones, A., & Burke, M. (Writer). (1999). *Animal farm* [Motion picture]. In R. Halmi, P. Lowin & G. Smith (Producer). Unites States: Live Artisan.
- Palika, L. (2008). *Your happy healthy pet German Shepherd dog*. Hoboken, NJ: Wiley.
- Passmore, D. (2004, 1 August). War on cruelty heats up: New links found between animal and child abuse. *The Sunday Mail*, p. 33.

- Patton, M. Q. (1990). *Qualitative evaluation and research methods*. Newbury Park, CA: Sage Publications.
- Paul, E. (2000). Love of pets and love of people. In A. Podberscek, E. Paul & J. Serpell (Eds.), *Companion animals and us: Exploring the relationship between people and pets*. Cambridge, MA: Cambridge University Press.
- Paxton, D. (1994). *Community involvement and urban dogs: Some ideas*. Paper presented at the Urban Animal Management Conference, Canberra, Australian Capital Territory, Australia.
- Pea, R. D. (1993). Practices of distributed intelligence and designs for education. In G. Salomon (Ed.), *Distributed cognitions: Psychological and educational considerations*. Cambridge, MA: Cambridge University Press.
- Pearsall, J. E. (1999). *The concise Oxford dictionary*. New York, NY: Oxford University Press.
- Peet, B., & Smith, D. (Writer). (1961). 101 Dalmatians [Motion picture]. In W. Disney (Producer). United States: Buena Vista Pictures.
- Peet, B., & Smith, D. (Writer). (2009). Space buddies [Motion picture]. In A. McRoberts & R. Vince (Producer). United States: Buena Vista Pictures.
- Pellegrini, A. D. (1991). *Applied child study: A developmental approach*. Hillsdale, NJ: Lawrence Erlbaum.
- Pert, C. (1997). *Molecules of emotion: Why you feel the way you feel*. London, England: Simon and Schuster.
- Phillips, B. (2007). Sparknote on animal farm. Retrieved 16 August, 2007, from <http://www.sparknotes.com/lit/animalfarm>
- Piaget, J. (1946). *Le developpement de la notion de temps chez l'enfant*. Paris, France: PUF.

- Pickett, J. P. (2006). *The American heritage dictionary of the English language*. Boston, MA: Houghton Mifflin Company.
- Pike, S. (2007). Repertory grid analysis in group settings to elicit salient destination brand attributes. *Current Issues in Tourism, 10*(4), 378-392.
- Popp, M. (2005). *Elementary classrooms: A resource book for professional development*. Hillsdale, NJ: Lawrence Erlbaum Associates.
- Poresky, R. (1996). Companion animals and other factors affecting young children's development. *Anthrozoos, 9*, 159-168.
- Postholm, M., Pettersson, P., Flem, A., & Gudmundsdottir, S. (2002). *The teacher's role when pupils use ICT as a mediating artefact in project work*. Paper presented at the ISCRAT Dealing With Diversity: Tools and Resources for Human Development in Social Practices, Amsterdam, The Netherlands.
- Pratt, D. D. (1991). Conceptions of self within China and the United States: Contrasting foundations for adult education. *International Journal of Intercultural Relations, 15*(3), 285-210.
- Pratt, D. D. (1993). Andragogy after twenty-five years. In S. G. Merriam (Ed.), *An update on adult learning theory: New directions for adult and continuing education*. San Francisco, CA: Jossey-Bass.
- Price, E. O. (2002). Pre-adaptations for domestication *Animal domestication and behaviour*. Oxfordshire, England: CAB International.
- Provet. (2003). The dog through evolution. Retrieved 12 July, 2003, from <http://www.provet.co.uk/dogs/evolution%20of%20the%20dog.htm>
- Randolph, J. J. (2007). Meta-analysis of the research on response cards: Effects on test achievement, quiz achievement, participation and off-task behaviour. *Journal of Positive Behaviour Interventions, 9*(113-128).

- Ratcliff, D. (2009). Analysis of field notes and other data sources. Retrieved 5 May, 2009, from <http://qualitativeresearch.ratcliffs.net/initialanalysis.pdf>
- Rathmann, C. (1999). Forget me not farm: Teaching gentleness with gardens and animals to children from violent homes and communities. In F. Ascione & P. Arkow (Eds.), *Child abuse, domestic violence and animal abuse: Linking the circles of compassion for prevention and intervention*. Lafayette, IN: Purdue University Press.
- Rice, D. (1999). *Training your German Shepherd dog*. Hauppauge, NY: Barrons Publishing.
- Roberts, M. (2010). Off-task behaviour in the classroom: NASP toolkit. Retrieved 1 July, 2010, from <http://www.napsoline.org>
- Roberts, M. H. (1944). The science of idiom: A method of inquiry into the cognitive design of language. *PMLA*, 59(1), 291-306.
- Robinson, W. S. (1951). The logical structure of analytic induction. *American Sociological Review*, 16(812-818).
- Rogoff, B., & Lave, J. (1984). *Everyday cognition: Its development in social context*. Cambridge, MA: Harvard University Press.
- Roseberry, K., & Rovin, L. (1999). Animal-assisted therapy for sexually abused adolescent females: The program at crossroads. In F. Ascione & P. Arkow (Eds.), *Child abuse, domestic violence and animal abuse: Linking the circles of compassion for prevention and intervention*. Lafayette, IN: Purdue University Press.
- Ross, S. (1999). Green chimneys: We give troubled children the gift of giving. In F. Ascione & P. Arkow (Eds.), *Child abuse, domestic violence and animal*

abuse: Linking the circles of compassion for prevention and intervention.

Lafayette, IN: Purdue University Press.

Rossbach, K., & Wilson, J. (1992). Does a dog's presence make a person appear more likable? Two studies. *Anthrozoos*, 5(1), 40-51.

Rowland, R., & Volet, S. (1996). Self-direction in community learning: A case study. *Australian Journal of Adult and Community Education*, 36(2), 89-102.

Rubin, A., & Babbie, E. (2007). *Research methods for social work*. Belmont, CA: Brooks Cole.

Ruff, H. A., & Capozzoli, M. C. (2003). Development of attention and distractibility in the first four years of life. *Developmental Psychology*, 39, 877-890.

Rummel, R. J. (1967). Understanding factor analysis. *The Journal of Conflict Resolution*, 11(4), 444-480.

Russell, C. G., & Cox, D. N. (2004). Understanding middle-aged consumers' perceptions of meat using repertory grid methodology. *Food Quality and Preference*, 15, 317-329.

Ryan, G. W., & Bernard, H. R. (2003). Techniques to identifying themes. *Field Methods*, 15(1), 85-109.

Ryan, L. (2010, 9 January). Barking dogs drive neighbours to distraction. *Hamptonville Bulletin*, p. 9.

Sachs, A. (2003). Love me, love my dog. *Time*, 161(22), 81.

Saettler, P. (1968). *A history of instructional technology*. New York, NY: McGraw Hill.

- Säljö, R. (1996). Mental and physical artifacts in cognitive practices. In P. Reimann & H. Spada (Eds.), *Learning in humans and machines: Towards an interdisciplinary learning science*. London, England: Pergamon.
- Sandelowski, M. (1995). Focus on qualitative methods: Sample size in qualitative research. *Research in Nursing and Health, 18*, 179-183.
- Sander, K., & Scheich, H. (2005). Left auditory cortex and amygdala, but right insula dominance for human laughing and crying. *Journal of Cognitive Neuroscience, 17*(10), 1519-1531.
- Sanguinetti, J., Maunders, D., & Waterhouse, P. (2003). *Generic skills and pedagogies of adult and community education: An action research exploration of teachers' practices*. Paper presented at the International Education Research Conference AARE-NZARE.
- Sapolsky, R. (1999). *Why zebras don't get ulcers: An updated guide to stress, stress-related diseases and coping*. New York, NY: W H Freeman and Company.
- Saral, T. (1976). *Consciousness theory and intercultural communication*. Paper presented at the International Communication Association.
- Saunders, C. R., & Robins, D. M. (1991). Dogs and their people: Pet-facilitated interaction in a public setting *Journal of Contemporary Ethnography, 20*, 3-25.
- Saville, P., Holdsworth, R., Nyfield, G., Cramp, L., & Mabey, W. (1984). *The Occupational Personality Questionnaire (OPQ)*. London, England: SHL.
- Sayers, S. (1978). *Leadership styles: A behavioural matrix*. Portland, OR: Northwest Regional Education Laboratory.
- Schine, C. (2007). *The New Yorkers*. New York, NY: Farrer, Straus and Giroux.

- Scoville, D. (2005). What K9 officers want you to know about their dogs. *Police: The Law Enforcement Magazine*, 29(10), 44-48.
- Scribner, S., & Cole, M. (1981). *The psychology of literacy*. Cambridge, MA: Harvard University Press.
- Sehe, J. (1998, 5 April). The best...The beautiful...And the bizarre; tail bonds; from housebroken to house calls. *The Los Angeles Times*, p. 6.
- Sennett, R. (1998). *The corrosion of character: The personal consequences of work in the new capitalism*. London, England: Norton.
- Serpell, J. (1990). *Evidence for long term effects of pet ownership on human health*. Paper presented at the Waltham Symposium 20: Pets, Benefits and Practice. First European Congress of the British Small Animal Veterinary Association, Cheltenham, England.
- Serpell, J. (1991). Beneficial effects of pet ownership on some aspects of human health and behaviour. *Journal of the Royal Society of Medicine*, 84, 717-720.
- Serpell, J. (2000). Animal companions and human well-being: An historical exploration of the value of human-animal relationships. In A. Fine (Ed.), *Handbook on animal-assisted therapy: Theoretical foundations and guidelines for practice*. San Diego, CA: Academic Press.
- Serpell, J. A. (2004). Factors influencing human attitudes to animals and their welfare. *Animal Welfare*, 12, 145-151.
- Shadbolt, D. R. (1978). Interactive relationships between measured personality and teaching strategy variables. *British Journal of Educational Psychology*, 48, 227-231.
- Sheared, V. (1994). Giving voice: An inclusive model of instruction - a womanist perspective. In E. Hayes & S. A. J. Colin (Eds.), *Confronting racism and*

- sexism: New directions for adult and continuing education*. San Francisco, CA: Jossey-Bass.
- Shepard, P. (1993). On animal friends. In S. Kellert & E. O. Wilson (Eds.), *The biophilia hypothesis*. Washington, DC: Island Press.
- Shepley, M. (2006). The role of positive distraction in neonatal intensive care unit setting. *Journal of Perinatology*, 26, 34-37.
- Sieber, J., O'Neil, H. F., & Tobias, S. (1997). *Anxiety, learning and instruction*. Hillsdale, NJ: Lawrence Erlbaum.
- Simpson, E. J. (1966). *The classification of educational objectives: Psychomotor domain*. Urbana, IL: University of Illinois Press.
- Smallwood, J. S., & Schooler, J. W. (2006). The restless mind. *Psychological Bulletin*, 132(946-958).
- Smith, E. (1999). Ten years of competency-based training: The experience of accredited training providers in Australia. *International Journal of Training and Development*, 3(2), 106-117.
- Soares, C. (2003). Huggable healthcare workers. Retrieved 10 July, 2003, from http://health.discovery.com/centers/aging/pet_therapy/pet_therapy_print.htm
- 1
- Spielberger, C. (1966). *Anxiety and behaviour*. New York, NY: Academic Press.
- Spradley, J. P. (1980). *Participant observation*. Fort Worth, TX: Harcourt Brace.
- Stateland. (2009). *Hamptonville economic overview*. Hamptonville, Queensland, Australia: Stateland Pty Ltd.
- Steed, A., & MccDonnell, J. (2003). *Experiences with repertory grid analysis for investigating effectiveness of virtual environments*. Paper presented at the Sixth International Workshop on Presence.

- Sterelny, K. (2005). Made by each other: Organisms and their environment. *Biology and Philosophy*(20), 21-36.
- Sternberg, R. (1985). *Beyond IQ: A triarchic theory of human intelligence*. Cambridge, MA: Cambridge University Press.
- Stewart, V., & Stewart, A. (1980). *Business applications of the repertory grid*. New York, NY: McGraw-Hill.
- Strauss, A. (1987). *Qualitative analysis for social scientists*. Cambridge, MA: Cambridge University Press.
- Strauss, A., & Corbin, J. (1990). *Basics of qualitative research: Grounded theory procedures and techniques*. Newbury Park, CA: Sage Publications.
- Sunder, S. (2002). Market as an artifact: Aggregate efficiency from zero intelligence traders. Yale University.
- Sunquist, M., & Sunquist, F. (2002). *Wildcats of the world*. Chicago, IL: University of Chicago Press.
- Taylor, E. W. (1998). *The theory and practice of transformative learning: A critical review. Information series no. 374*. Columbus, OH: ERIC Clearing House on Adult Career and Vocational Education, Center on Education and Training for Employment, College of Education, The Ohio State University.
- Tennant, M., & Pogson, P. (1995). *Learning and change in the adult years: Developmental perspective*. San Francisco, CA: Jossey-Bass.
- Thompson, D. (1995). *The concise Oxford dictionary*. New York, NY: Oxford University Press.
- Thorne, S. (2000). Data analysis in qualitative research. *Evidence-Based Nursing*, 3, 68-70.

- Thuen, E., & Bru, E. (2000). Learning environment, meaningfulness of schoolwork and on-task orientation among norwegeian ninth grade students. *School Psychology International, 21*, 393-413.
- Tiger, L. (1992). *The pursuit of happiness*. Boston, MA: Little, Brown and Company.
- Tilley, L. P., & Tilley, L. P. (2008). *Manual of canine and feline cardiology*. St. Louis, IL: Elsevier.
- Townsend, H. (2003, 23 October). Sixth-graders with dogs help younger kids hone reading skills. *The San Diego Union-Tribune* Retrieved 14 March, 2004, from http://legacy.signonsandiego.com/news/education/20031023-9999_m1m23tfencin.html
- Trachtman, P. (2003). To the rescue. *Smithsonian, 33*(12), 91-98.
- Travis, G. Y. (1985). Andragogy and the disabled adult learner. *Adult Learning, 8*(8), 16-20.
- Trochim, W., & Donnelly, J. P. (2007). *The research methods knowledge base*. Mason, Ohio: Cengage Learning-Atomic Dog.
- Trzepacz, P., & Baker, R. (1993). *The psychiatric mental status examination: First edition*. New York, NY: Oxford University Press.
- Tsuang, H. W. H., Paterson, M., & Packer, T. (2002). Self-directed learning in fieldwork education with learning contracts. *British Journal of Therapy and Rehabilitation, 9*(5), 184-189.
- Tuckman, B. (1965). Developmental sequence in small groups. *Psychological Bulletin, 63*(6), 384-399.
- Tuckman, B. W., & Jensen, M. A. (1977). Stage of small-group development revisited. *Group Organisational Studies, 2*, 419-427.

- Turnure, J. E. (1970). Children's reactions to distractors in a learning situation. *Developmental Psychology*, 2, 115-122.
- Tusting, K., & Barton, D. (2003). *Models of adult learning: A literature review*. Lancaster, England: Lancaster University.
- Utlah. (2003). The origins of lycanthropy: Part one: The invisible paw. Retrieved 27 July, 2003, from <http://www.swampfox.demon.co.uk/utlah/articles/origins1.html>
- Veale, A., & Piscitelli, B. (1988). *Observation and record keeping in early childhood programs. Australian early childhood resource booklets number 1*. Watson, Australian Capital Territory, Australia: Australian Early Childhood Association Inc.
- Vialles, N. (1994). *Animal to edible*. Cambridge, MA: Cambridge University Press.
- Vygotsky, L. S. (1962). *Thought and language*. Cambridge, MA: The MIT Press.
- Vygotsky, L. S. (1978). *Mind in society: The development of higher psychological process*. Cambridge, MA: Harvard University Press.
- Wade, N. (2002, 22 November). From wolf to dog, yes, but when? *The New York Times* Retrieved 12 August, 2003, from <http://www.nytimes.com/2002/11/22/us/from-wolf-to-dog-yes-but-when.html>
- Walker, F. (2003, 29 June). It's a dogfight over pets at city's cafes. *The Sun-Herald*, p. 34.
- Watson, L. (1998). *Literature review: Pet facilitated therapy in correctional institutions*. Ottawa, Ontario, Canada: Office of the Deputy Commissioner for Women, Correctional Service of Canada.

- Wertsch, J. V. (1985). *Vygotsky and the social formation of mind*. Cambridge, MA: Harvard University Press.
- Wertsch, J. V. (1991). *Voices of the mind: A sociocultural approach to mediated action*. Hemel Hempstead, England: Harvester Wheatsheaf.
- Whetten, D., & Cameron, K. (1984). *Development management skills*. London, England: Scott Foreman.
- Wilson, E. O. (1984). *Biophilia*. Cambridge, MA: Harvard University Press.
- Wilson, E. O. (1992). *The diversity of life*. Cambridge, MA: Harvard University Press.
- Wilson, E. O. (1993). Biophilia and the conservation ethic. In S. R. Keller & E. O. Wilson (Eds.), *The Biophilia Phythesis*. Washington, DC: Island Press.
- Wragg, E. C. (2001). *An introduction to classroom observation*. London, England: Routledge.
- Yerkes, R., & Dodson, J. (1908). The relation of strength of stimulus to rapidity of habit-formation. *Journal of Comparative Neurology and Psychology*, *18*(459-482).
- Zawistowski, L. (2003). Science watch: Dogs, darwin and the whole damn thing! Retrieved 12 July 2003, from http://www.aspca.org/site/PageServer?pagename=awatch_science
- Zhu, R. X., Potts, R., Hoffman, K. A., Deng, C. L., Shi, C. D., Pan, Y. X., et al. (2004). New evidence on the earliest human presence at high northern latitudes in North East Asia. *Nature*, *431*(7008), 559.

APPENDIX A: RESEARCH INTO ANIMAL—HUMAN RELATIONSHIPS

Reference	Anderson et al. (1992)
Focus	Evaluation of the effects of pet ownership on cardiovascular health.
Methodology ¹⁸	Data on 5000 clients were analysed over a 3-year period, including triglyceride levels, blood pressure, and cholesterol.
Findings	Pet owning women older than 40 and male pet owners of all ages had lower blood pressures and 20% lower plasma triglyceride levels than did non-owners. Male pet owners between 30-60 years of age had lower cholesterol levels than did non-owners. No difference in exercise levels, body mass or eating habits were found between the two groups.
Reference	Ascione and Weber (1996)
Focus	Development of humane attitudes.
Methodology	A year long school based humane education programme amongst children – attitudes towards animals generalizes to human empathy.

¹⁸ Methodology as reported in primary reference source and includes all details available. Some studies did not include a detailed methodology.

Findings	Found a higher mean for human attitudes than for a control group, even a year after the programme ended. Enhanced attitudes toward animals generalized to human-directed empathy, especially when the quality of the children's relations with their pets was considered as a covariant.
Reference	Bardill (1997)
Focus	How hospitalized adolescents are perceived to respond in the presence of a dog, and the dog as a catalyst for interactions, improved self-esteem, a good distraction and a sense of safety.
Methodology	Used ethnographic methods.
Findings	Hospitalised adolescents responded positively to the presence of a dog. The dog was a catalyst for interactions, improved self-esteem, a good distraction and a sense of safety.
Reference	Beck, Seraydarian and Hunter (1986)
Focus	Effects of animals in improving the perceived quality of the environment for psychiatric inpatients.
Methodology	Experimental and control group comparing exposure to caged birds. Used observation.
Findings	The group in the room with birds was more comfortable talking and participated more than those in the same room without animals present.
Reference	Bierer (2000)
Focus	Relationship between pet bonding, self-esteem and empathy in

preadolescents.

Methodology	<p>Investigated the relationship between the intensity of the companion animal bond and levels of self-esteem and empathy in dog-owning fifth-graders. Hypotheses regarding the impact of owning and bonding with a dog during preadolescence, as well as the impact of this relationship on self-esteem and empathy were investigated. Involved 126 volunteer students from three elementary schools. Sample consisted of 60 males and 65 females 10-12 years of age in regular education. Participants included both students who owned dogs (95) and those who did not (31). Data was collected in classrooms in one phase and participants completed a demographic survey, a self-esteem measure (Coopersmith Self-Esteem inventory, short Form), and an empathy measure (Index of empathy for children and adolescents). Dog owners completed a pet bonding measure (Pet Bonding Scale). Statistical analysis included independent t-tests, Pearson product-moment correlations and a one-way ANOVA.</p>
Findings	<p>Dog owners had statistically significantly higher mean self-esteem and empathy scores than children without dogs. Results showed no statistically significant relationship between self-esteem and strength of bonding for dog owners, or between strength of bonding and empathy for dog owners.</p>
Reference	Batson, McCabe, Baum and Wilson (1998)
Focus	The value of pets for particular groups of people.

Methodology	No details available.
Findings	The presence of a therapy dog enhanced nonverbal communication as shown by increases in looks, smiles, tactile contact and physical warmth in Alzheimer's patients. However these behaviours declined 4 weeks post test.
Reference	Burgess (1997)
Focus	Animal assisted therapy and the enhancement of mood in elderly nursing home residents.
Methodology	Animal assisted therapy used as an intervention in one skilled nursing facility. Participants were given a pretest before the intervention and a posttest after. An experimental group received an intervention of group therapy including dogs, whereas the control group received group therapy without a dog. Thirty residents were invited and fourteen people participated. Baseline depression levels of subjects were gathered using the CES-D Scale for Depression test (a public domain test developed by the national Institute of mental Health, National Institutes of Health, Bethesda, MD. Testing was completed during the morning hours between breakfast and lunch. Both groups were completed at two sessions over 2 weeks, and a final CES-D testing in week 4. ANOVA and t-tests were used to analyse the data, using the SPSS/PC+ computer programme. Subjects were also given a demographic study.
Findings	Positive correlation between the presence of a pet in the group and an enhancement of mood in the subjects. Interaction between the experimental group subjects was of increased energy and more

physical interaction. Physical interactions between the dog and patients appeared to be conducive to an increase in verbal interaction. There was a higher rate of reduction in depression in the experimental group, which had the added variable of a dog present with which the subjects could interact.

Reference	Crowley-Robinson et al. (1996)
Focus	Evaluation of the role of pets in nursing home setting.
Methodology	Controlled study including 95 residents from 3 different homes (resident versus visiting pet), were compared for dimensions of tension, depression, vigour, confusion, anger and fear. Started 4 month prior to dog visits, and ended 3 months after.
Findings	Reduced tension and confusion were most strongly associated with a resident dog, although a visiting dog also produced similar response but to a lesser degree. Depression, vigour, and fatigue dropped for all three groups to some degree, which signifies the benefits of a resident pet or a visiting pet.
Reference	Friedmann et al. (1980)
Focus	Association of pet ownership and survival for cardiovascular patients.
Methodology	Epidemiological study of 92 patients, which lead to large sample group of 369 patients.
Findings	Among people with equally severe disease, pet owners were less likely to die than non-owners.

Reference	Heimlich (2001)
Focus	Quantitatively measure the therapeutic outcomes of children presented with an animal assisted therapy programme over a two-month period.
Methodology	Fourteen subjects received animal assisted therapy intervention over two trials, with seven students in each group, and a total of six females and eight males aged 7 to 19 years. Students were diagnosed with severe to moderate mental retardation and other diagnoses. Students were taken out of their regular schedules to participate. Researcher developed instrument, Measurement of pet Intervention (MOPI), and unvalidated test, using four items evaluated on a Likert scale of one to seven. The four items were attention span, physical movement, communication and compliance. Students were assessed over time from the beginning of the trial to the end. Also used Achenbach's Direct observation Form and Teachers Report Form of the Child Behaviour Checklist. Also used the Behaviour Dimensions Rating Scale (BDRS) by Bullock and Wilson (1989) to measure aggression, attentiveness, socially withdrawal and fear/anxiousness. Each trial consisted of two 30-minute sessions every week for eight weeks. Reported rater error, inconsistency and bias and trials ended early due to adverse effect on the dog, Cody.
Findings	Positive benefits of animal assisted therapy for up to 12 out of the 14 students, though due to inter-rater error, no generalizations were made.

Reference	Henderson (1997)
Focus	Moral reasoning, empathy and behaviour of students with and without emotional and behavioural disorders and learning disabilities: Impact of a structured programme of experiential learning activities involving animals and nature.
Methodology	Two design approaches: a descriptive design and a quasi-experimental, pretest and posttest design. Moral reasoning was assessed using a researcher-developed measure of scenarios about moral transgressions. Empathy was assessed using Bryant's Index of Empathy for Children and Adolescents. Prosocial behaviour was assessed by Behaviour Evaluation Scale-2 (McCarney & Leight, 199), a teacher rating scale. Three sites included two elementary and one middle, large public school. Children between Kindergarten to grade 8 were included. One hundred and twenty-two students participated in the study, amongst six groups including special education students with emotional and behaviour disorders, learning disabilities, non-identified general education students and non-identified general education and special education students.
Findings	Findings: were inconclusive and analyses insufficient to comprehensively affirm or deny hypotheses.
Reference	Katcher et al. (1983)
Focus	Physiological effects of looking at or observing animals or pictures

of animals.

Methodology	Blood pressures of 20 normotensive and 15 hypertensive subjects were measured while watching fish. [Note, similar studies have been done on implicitly observing animals, where the animal or picture is present but the subject is not directed to focus: on the animal.
Findings	Lowered levels of physiologic indicators of parasympathetic nervous system arousal, blood pressures decreased while watching fish in an aquarium.
Reference	Katcher and Wilkins (1994)
Focus	Centaur's Lesson: Designed to facilitate improved functioning of children with conduct disorder (CD) and attention deficit hyperactivity disorder (ADHD).
Methodology	A sample of 52 children was randomly assigned to voluntary experiences that complemented regular school and treatment. One group participated in a 6-month Outward Bound programme and the second group participated in a 6-month nature and companionable zoo programme. Each involved a commitment of 5 hours per week. At the end of the 6-month period, the Outward Bound group was transferred to the Companionable Zoo condition and the Companionable Zoo group was returned to the regular school programme, however they were allowed to visit their animals during their free time. This partial cross-over design meant children could still visit their animals otherwise it would

	<p>have been unethical for them not to visit the animals for 5 weeks. Aggressive behaviours as measured by the need for restraints for aggressive episodes were counted. Used Achenbach Child Behaviour Checklist relying on teacher reports resulting in bias.</p>
Findings	<p>Fewer aggressive behaviours, accelerated learning, significant reduction in total behavioural pathology.</p>
Reference	<p>Kellert (1980)</p>
Focus	<p>American attitudes towards animals.</p>
Methodology	<p>Used 10 different typologies of attitudes in society in developing survey.</p>
Findings	<p>The two most prevalent attitudes in American society were humanistic (associated with pets, wildlife tourism and zoo visitation) and naturalistic (associated with the avoidance of animals). Each typology could be identified in about 35% of the American population.</p>
Reference	<p>Kidd and Kidd (1980)</p>
Focus	<p>Attempt to measure personality differences between pet cat and dog owners.</p>
Methodology	<p>Interviews and observations of 102 parents and 102 children aged 3-12 years.</p>
Findings	<p>Cat lovers scored lower on nurturance and dog lovers scored higher on aggression and dominance than those in other groups.</p>

Reference	Lieber (2002)
Focus	Animal-assisted therapy for elementary students with emotional or behavioural disorders.
Methodology	This study investigated the perceived impact of animal-assisted therapy on the social/behavioural and emotional functioning of elementary students with emotional or behavioural disorders. Two students were studied for ten weeks using a multiple case study design as they participated in AAT with trained therapy dogs. Parents and educators were interviewed and completed behaviour rating forms at the beginning and end of the study. Student subjects were interviewed at the beginning and end of the study, and the 30-minute AAT sessions were videotaped.
Findings	Parents identified positive changes including less disruptive behaviour, better peer relationships, improved communication with adults, and feelings of acceptance. School counsellor and special education teacher also noted improvements in these areas, as well as the ability to cope with anxiety and overall behaviour. General education teachers tended to observe less of an impact from the AAT sessions. Both interviews and behavioural rating scales yielded little perceived improvement in social or emotional functioning. One general education teacher did, however, identify an increased ability to read the moods of others as a skill that she attributed in part to the AAT.
Reference	Lockwood (1983)

Focus	Effects of explicitly looking at or observing animals or pictures of animals.
Methodology	A total of 68 young people rating pictorial scenes with people and those that included animals.
Findings	<p>Pictorial scenes and the people depicted therein were perceived as more friendly, less threatening and happier when animals were included in these scenes than when animals were not included.</p> <p>Pictures of people with dogs were rated more highly than pictures of people with flowers. People in photographs were perceived as more relaxed and happy when the dog was present.</p>
Reference	Miller et al. (2003)
Focus	How animal-assisted therapy affects discharge teaching.
Methodology	<p>A pilot study using a quasi-experimental, before-and-after design, involving patients who were being discharged following median sternotomy open heart surgery. These patients were undergoing discharge teaching. A control group of 13 and an experimental group of 17 patients aged 48 to 88 years of which 18 were men and 12 were women. All patients were given a pretest within 48 hours before discharge without a dog present to determine baseline knowledge. Experimental group members received discharged teaching with a certified therapy dog present. Both groups were post-tested within 24 hours. Data analysis was done using the Statistical Package for the Social Sciences software. Control group scored higher on the post-test due to distraction from learning by</p>

	the dog.
Findings	Control group scored higher on post-test than experimental group due to distracting novelty value of the presence of the dog.
Reference	Myers (1998)
Focus	Ethnographic study of children in a nursery school and their relationship with pet animals in the classroom.
Methodology	Observation.
Findings	Children displayed a special relationship and understanding of animals through pretend play and in preverbal as well as verbal experience.
Reference	Saunders and Robins (1991)
Focus	Determine the effect of the presence of a dog between unacquainted strangers.
Methodology	Participant-observation study to determine the effects of the presence of a dog between unacquainted strangers.
Findings	Dogs facilitate interaction among strangers and help establish trust.
Reference	Serpell (1991)
Focus	Pet ownership and its associated with increased level of well-being.
Methodology	Prospective study in the changes of behaviour of 71 adults following pet acquisition (dog or cat) compared to a non-matching

control group of 26 adults.

Findings

Dog and cat owners reported a reduction in minor health problems during the first month following acquisition. In dog owners, the health effects were maintained for the full 10-month period of the study. Both pet owner groups demonstrated improvements in psychological well-being after the first 6 months and persisted in dog owners for the full 10 months. Dog owners fared better overall than cat owners, who fared better than the control group.

APPENDIX B: PRE-COURSE QUESTIONNAIRE

1. Name:
2. Gender:
3. Age:
4. Highest schooling achieved: High school
TAFE
Degree
Post Graduate
5. Year last attended school:
6. What pets did you have growing up?
7. What pets have you had as an adult?
8. What positive experiences have you had with animals?
9. What negative experiences have you had with animals?
10. Please describe any fears you may have about dogs being in the classroom?
11. Please describe any health concerns you may have about dogs being in the classroom?
12. What advantages do you think you and others will experience by having a dog in the classroom?
13. What disadvantages do you think you and others will experience by having a dog in the classroom?

14. Rate your disposition towards dogs in general using the scale below

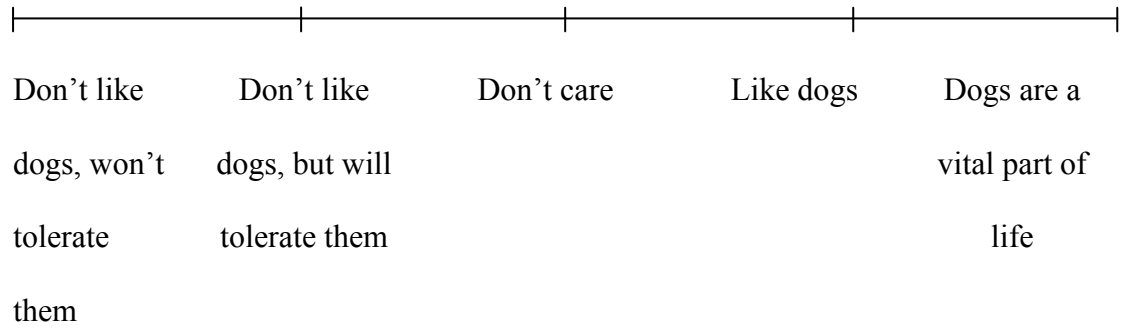

15. Do you have any comments?

APPENDIX C: EVENT INTERVIEW GUIDE

Start the Discussion

Step	Action
1. Explain the purpose.	I'd like to have a short discussion to help me understand what happened when [incident or event] happened, and how you saw things.
2. Explain the process.	<p>This is a very informal discussion, and there's no right or wrong answer. I'm particularly interested in hearing your point of view.</p> <p>I've got a few general questions to help generate some discussion, and it should only take about 10-15 minutes. Do you have that time now?</p> <p>We'll come back to some of this during the rest of the course, and afterwards, and we'll have an opportunity to build on it and talk about it some more.</p>
3. Ask some general questions	I'd like you to tell me what you saw happening at the time, leading up to and after the event.

Generate Discussion

Step	Action										
4. Enquire	Use Line of Enquiry Questions to stimulate conversation.										
	<table border="1"> <thead> <tr> <th data-bbox="663 546 868 577">Line of Enquiry</th> <th data-bbox="1027 546 1254 577">Trigger questions</th> </tr> </thead> <tbody> <tr> <td data-bbox="651 689 791 792">Cognitive influences.</td> <td data-bbox="879 689 1382 1016"> What do you remember thinking at the time? What do you think others were thinking? Why is that? </td> </tr> <tr> <td data-bbox="651 1057 791 1160">Affective influences.</td> <td data-bbox="879 1057 1390 1240"> How did it make you feel? What do you think others were feeling? Why is that? </td> </tr> <tr> <td data-bbox="651 1281 791 1384">Social and cultural.</td> <td data-bbox="879 1281 1382 1532"> How would you explain the way other people reacted? What were you expecting others to do? Why is that? </td> </tr> <tr> <td data-bbox="651 1572 826 1603">Environment.</td> <td data-bbox="879 1572 1374 1756"> What effect do you think it had on the group? Why is that? </td> </tr> </tbody> </table>	Line of Enquiry	Trigger questions	Cognitive influences.	What do you remember thinking at the time? What do you think others were thinking? Why is that?	Affective influences.	How did it make you feel? What do you think others were feeling? Why is that?	Social and cultural.	How would you explain the way other people reacted? What were you expecting others to do? Why is that?	Environment.	What effect do you think it had on the group? Why is that?
Line of Enquiry	Trigger questions										
Cognitive influences.	What do you remember thinking at the time? What do you think others were thinking? Why is that?										
Affective influences.	How did it make you feel? What do you think others were feeling? Why is that?										
Social and cultural.	How would you explain the way other people reacted? What were you expecting others to do? Why is that?										
Environment.	What effect do you think it had on the group? Why is that?										

 During the Discussion

Step	Action
5. Use probes to delve deeper. Ask for illustrative examples. Give signs of interest such as a nod. Probe for feelings as well as facts. Foster storytelling.	Can you tell me about how you were feeling when...?
6. Listen to what is not being said.	

 Close the Discussion

Step	Action
7. Thank the person.	Thanks for efforts and time during this discussion.
8. Explain the next steps.	If you've got any questions, or you think of anything else that you'd like to add, please let me know and we can arrange time for another chat. As we go through this course, I'll be catching up with people to talk about their perceptions and experiences. We'll also have the opportunity to build on what we've spoken about today. At the

Step	Action
	end of the course I'd like to catch up for a final discussion.

APPENDIX D: REPERTORY GRID TECHNIQUE

The repertory grid technique arose out of personal construct theory and was developed by George Kelly (1955) as a methodology to explore people's construct maps, that is, their system of related meanings and perceptions about the world they live in (Neimeyer & Neimeyer, 2002; Stewart & Stewart, 1980). According to Kelly's personal construct theory, people build individual mental construct maps to explain the observed world around them, including people, situations, events and material objects (Norman, 2000).

The repertory grid technique is an established research tool that has been used in over 3,000 studies in subject areas that include tourism, career development, consumer marketing, team and leadership development, mental health and parental care, user experiences of technology, and owner attitudes and dog behaviour problems (Jankowicz, 1990; McKnight, 2000; Naoi, Airey, Iijima, & Niininen, 2006; Neimeyer & Neimeyer, 2002; O'Farrell, 1997; Russell & Cox, 2004; Steed & MccDonnell, 2003; Stewart & Stewart, 1980). Therefore, the repertory grid technique was considered an appropriate and valuable data collection tool for this research because of its established use across a wide range of subject areas and its ability to reveal people's emic understandings.

The repertory grid technique was used in this research to build an understanding of the way participants viewed the dogs and their interactions with them, and to reveal their system of related meanings and perceptions about the classroom environment. If behaviour is influenced by perception as suggested Gibson (1966), Pea (1993), and Piaget (1946), then these constructs maps may reveal clues to the way dogs may be seen to function as artifacts in vocational and educational training settings.

Technique

The repertory grid technique uses a semi-structured interview situation to determine an individual's perception of a particular subject. Norman (2000) suggests that compared to other interview methods, the repertory grid technique minimises respondents' views being subject to external bias or influence as the interviewer has a minimal role during the interview process. McKnight (2000) points out that the repertory grid technique allows a person to verbalise how they perceive elements or facets that when analysed, can help the researcher construct a picture of their concept model for a particular domain.

The repertory grid technique sees the interviewee compare and contrast sets of three significant elements such as people, events, objects or activities, and elicits some important way that two of the elements are alike, and yet are different from the third (Neimeyer & Neimeyer, 2002; Stewart & Stewart, 1980). These bipolar dimensions of difference represent extremes of perception or constructs underlying a person's concept map (McKnight, 2000; Neimeyer & Neimeyer, 2002; Stewart & Stewart, 1980).

For example, by considering the differences and similarities between three animals, ostrich, penguin and panda, constructs about them can be identified. These constructs might include: Bird—Not Bird that requires an understanding of the construct of bird; Black-and-White—Multi-Coloured that requires an understanding of the construct of colour and black-and-white; Found in Northern Hemisphere—Found in Southern Hemisphere that requires an understanding of the construct of global hemispheres; and Name Starts with Vowel—Starts with Consonant that requires an understanding of the constructs of letters, vowels and consonants. There is no judgement about what is good or bad, right or wrong about the bipolar

dimensions of the constructs identified. McKnight (2000), Neimeyer and Neimeyer (2002) and Stewart and Stewart (1980) argue that this lack of observer bias is one of the key strengths of technique.

Fransella and Bannister (1977) explain that the next step in the technique involves constant comparison and evaluation of all elements against the constructs elicited to develop a matrix grid that can be analysed to reveal a picture of a person's construct map. The discussion guide included at Appendix E was developed to facilitate the repertory grid technique discussion and involved four stages: element selection, construct elicitation, laddering and attribute evaluation.

Element Selection

The objects being compared are referred to as elements, and as suggested by Fransella and Bannister (1977), McKnight (2000), and Stewart and Stewart (1980), they help define the kind of conversation between the researcher and person, and helps keep the interview focussed. Fransella and Bannister (1977), McKnight (2000) and Stewart and Stewart (1980) describe three different ways that elements around the phenomena being studied can be selected: before the interview by the researcher; by asking the interviewee to generate a list spontaneously once the researcher has told them broadly what class of elements is sought; or by the researcher providing a list of questions, the answers to which are the elements.

Stewart and Stewart (1980) suggests that elements should be carefully decided, and point towards a number of criteria for good elements. Firstly, elements should be discrete nouns or verbs, the most often used being people, objects, events and activities. Secondly elements should be specific and loose descriptions such as Negotiating or Thinking should be avoided. Elements should also be homogenous, and avoid mixing classes of elements such as people with things, or things with

activities. Elements should not be a sub-set of other elements such as Making Presentations and Making Presentations to the Managing Director, as the smaller element will contain so many features similar to the larger element that they will be difficult to compare and contrast during construct elicitation. Finally Stewart and Stewart (1980) suggest that elements should not be evaluative, for example, Motivating Staff, and should be value-neutral.

For this research, elements were selected before the interview to provide consistency across people being interviewed, to maximise available time for the discussion, and to keep the interview and concept map focussed on the selected phenomena. The elements chosen for this research were drawn from the actors in the social learning domain and included teachers, students and dogs. Dogs were not contrasted with inanimate artifacts in the classroom, since to contrast living and inanimate artifacts would have mixed classes of elements. Stewart and Stewart (1980) suggest that this would have produced a list of elements that were not homogenous. Fransella and Bannister (1977), McKnight (2000), and Stewart and Stewart (1980) suggest that the repertory grid technique traditionally uses eight, nine, 12 or 24 elements. However in this study all students, teachers and dogs were included to saturate the data, to provide depth to the dialogue, and to provide adequate opportunity for contrasting and evaluating.

Construct Elicitation

The next step in the repertory grid technique focuses on construct elicitation from interviewees. Fransella and Bannister (1977) and Stewart and Stewart (1980) suggest that construct elicitation can be seen as a technique in its own right that allows examination of an individual's vocabulary about the particular domain of the world of interest to the researcher. They also provide consistent approaches for

completing this stage of the technique. Construct elicitation starts with writing each element on a separate index card, and providing the interviewee with a general orientation to the procedure. Three cards referred to as a triad are then placed on the desk in front of the interviewee who is asked to think of one way that two of the items represented are like each other and different from the third. The person's response is recorded in the form of a bipolar contrasting pair. For example, when presented with three cards representing car, train and donkey, an interviewee might respond that two of these elements have wheels and the other legs, or that two are hard whilst the other one is furry. This provides two bipolar constructions: Have Wheels—Have Legs and Hard—Furry. The next triad is presented and the construct elicitation process repeated for all elements in turn.

Fransella and Bannister (1977) note that constructs are composed of contrasts that are not necessarily semantic or logical opposites, where behind modified and prefixed words there is less meaning. For example, the inferred meaning or latent value of the construct Critical—Uncritical is different to Critical—Accepting because Uncritical can infer the absence of criticism but does not necessarily infer a meaning of acceptance. Fransella and Bannister (1977) and Stewart and Stewart (1980) suggest that during construct elicitation a record of which pair of elements shared similarities and which shared differences should be made alongside each construct. This provides a record of how the constructs were derived should there be a need at a later date to go back and do further work. Fransella and Bannister (1977) and Stewart and Stewart (1980) also suggest the use of prompting questions during construct elicitation to provide a frame of reference to focus the context of the constructs. Prompting questions include: In what ways are two of these similar to each other and different from the third? Tell me

something that two of these have in common which makes them different from the third? Tell me something about two of these that makes them different from the third in the way they help you learn? Tell me about the demands these activities make on your skills? Are two of them similar in demands and different from the third?

In this research, the interviewee was always placed at the centre of each triad of elements so that they could contrast their perceptions of self against other people and the dogs. The remaining pair of elements was drawn at random and was not planned prior to conducting the repertory grid technique. Stewart and Stewart (1980) suggest that it is not necessary to exhaust all possible triad combinations of all selected elements, which would have resulted in an unmanageable number of triads to compare. An arbitrary limit of nine triads was presented to each person to balance the amount of time taken to conduct the repertory grid technique with the quality of data collected.

Laddering

Stewart and Stewart (1980) argue that a construct system is not simple a collection of assorted perceptions, but rather it is a hierarchy with some constructs closer to the centre or essence of the person and others more peripheral. Therefore, a person's construct system can be seen as analogous to a set of interlocking ladders, where the constructs become smaller in number and stronger in influence the closer they lie to the centre of the person's concept map.

Stewart and Stewart (1980) suggest the use of a technique they call laddering during construct elicitation to explore higher-order constructs that lie closer to the centre of a person's concept map, by asking question such as: Why do you prefer *x* over *y*; or Why is that important to you? They also suggest exploring

constructs that may lie further down the ladder, by asking questions such as, Tell me more about how x differs from y .

Stewart and Stewart (1980) argue that the process of laddering allows a deeper exploration of the individual's constructs. For example, in considering the construct High Work Standards—Low Work Standards, laddering up questions may include: Why is that an important distinction to make about people at work? Why do you prefer working with people who have high work standards or people who have a low one? Using the same construct High Work Standards—Low Work Standards, laddering down questions may include: In general, how do people who have high work standards differ from people who have low work standards; How does the behaviour of one class of people differ from the other?

The following transcript excerpt from Danni's repertory grid discussion illustrates how the laddering technique was used in this research:

RESEARCHER: Is tactful the right word to describe what you were thinking of there?

DANNI: Tactful as in not blunt. I don't know. Sam's definitely not tactful. I don't know another word to use.

RESEARCHER: Okay, what does somebody do who's not tactful? What did Sam do that wasn't tactful?

DANNI: I think she discussed things about herself. I'm reserved maybe, that's the opposite. Like, said things that she shouldn't have...

RESEARCHER: Said things that were inappropriate?

DANNI: Yes.

RESEARCHER: That she shouldn't have been talking about?

DANNI: Yes, yes.

RESEARCHER: So, if we look at maybe reserved being a word here, and then inappropriate as being a word here.

DANNI: And that changes this a little bit because I don't think.

Attribute Evaluation

The final section of the repertory grid technique is attribute evaluation. According to Fransella and Bannister (1977) and Stewart and Stewart (1980), attribute evaluation allows the researcher to elicit how the construct system actually works by regarding each construct not only as a pair of words, but also as a scale. The interviewee is asked to rate each element on each construct using a five-point Likert scale that builds up into a matrix of elements and constructs shown at Figure D1. This matrix allows the researcher to get closer to the person's functional meaning of the elements and constructs.

	Lady	Adonis	Buddy	Reggie	Sharon	Dan	Andrea	Morgan	Mary	Danni	Borat	Leigh	Wynnne	Mark	Coral	Andy	Wade	Brad	Sam	Alma	
Happy Energetic	1	5	4	1	5	4	4	4	2	3	3	1	5	3	1	4	3	4	5	4	Formal Precise
Outspoken Out of Turn	1	5	3	2	3	2	4	3	1	3	3	1	4	3	1	4	2	3	4	3	Disciplined
Philosophical Metaphysical	1	3	4	3	3	1	5	4	3	1	1	1	5	3	2	3	3	1	1	4	Practical
Intense	5	1	1	5	2	4	1	2	5	5	5	5	1	3	5	1	2	1	1	2	Casual
Purpose to be Here	1	1	1	1	5	5	5	5	5	3	5	5	5	5	2	4	5	4	5	5	Not Sure Why Here
Tolerant Patient	1	1	5	1	5	3	5	5	3	1	5	4	5	4	1	5	5	5	5	5	Not Accepting Stroppy

Figure D1. Completed repertory grid.

APPENDIX E: REPERTORY GRID TECHNIQUE DISCUSSION GUIDE

Start the Discussion

Step	Action
1. Explain the purpose of the discussion.	The purpose of this discussion is to help me understand how you view dogs and people in the learning environment, and to hear about your experiences and beliefs.
2. Explain the process.	We're going to do a card sort exercise similar to the one we did before the course. You remember that process? Good, this will help me draw a picture of how you see dogs and other people in the learning environment. We'll also try to pick up on some of the things that happened during the course, and our previous discussions.
3. Ask some general questions	To start with, can you tell me how you found having a dog in the classroom?

Introduce the Repertory Grid Technique

Step	Action
4. Explain the purpose.	<p>Now I'd like to do a card sort exercise called repertory grid technique that we can use to generate some more discussion about your experiences and how you see dogs and people in the classroom.</p> <p>The purpose is to draw up a picture of your perceptions, and how you feel about them.</p>
5. Explain the process.	<p>I'm going to put out three cards with a different person and dog on each, and I'd like you to tell me something about two of them, that makes them different from the others in terms of how you feel about them.</p> <p>What I want you to think about are the differences in the way you feel about them, your perceptions and expectations.</p> <p>I also want you to think of the difference as another word, rather than using the literal opposite such as outgoing and reserved, rather than outgoing and not outgoing.</p> <p>It may help you to think about a specific incident that occurred during the course.</p>
6. Elicit constructs.	<p>In what ways are two of these similar to each other and different from the third?</p> <p>Tell me something that two of these have in common</p>

Step	Action
	<p>which makes them different from the third?</p> <p>Why?</p> <p>How does that make them different from the third?</p>
7. Frame constructs.	<p>Tell me something about two of these that makes them different from the third in the way they make you feel?</p> <p>What did you expect from these two? Which did you prefer to be around?</p>
8. Ladder up.	<p>Why do you prefer x over y?</p> <p>Why is that important to you?</p> <p>Which do you think it is more important to be, elements that are x or elements that are y?</p> <p>Why is that an important distinction to make about [element or construct]?</p>
9. Ladder down.	<p>Tell me more about how x differs from y.</p> <p>In general, how do elements that have [element or construct] differ from elements that have low ones?</p>
10. Enquire.	<p>Use Line of Enquiry Questions to stimulate conversation between each triad sort if possible. Alternatively, ask them at the end of the card sort, check again at the end of the rating.</p>

Step	Action
Line of Enquiry	Trigger questions
Animal Experiences and value of animals.	<p>Was there anything that happened during the class that stood out for you? How did the dog influence your thinking and outlook How did that make you feel? Why was that important? What do dogs mean to you?</p>
Animals as mediators.	<p>How do you think having the dogs there influenced what people did and the way they behaved? Is there a particular example you can think of? What about when [incident] occurred? How did that makes you feel? Why was that important? How did that influence the group?</p> <p>Do you think there's anything people learned from them?</p> <p>Were there any situations when you felt more comfortable with a dog than say another person?</p>

Step	Action
11. Review constructs.	<p>Are you happy with these words?</p> <p>Are there any that we need to clarify?</p> <p>Are there any overlaps or duplications?</p> <p>Are there any others that we've missed that you'd like to add?</p>
12. Enquire.	Check for any unasked enquiry questions.
13. Rate constructs.	<p>Now I'd like to take each card we've looked at here, and rank them from 1 to 5 against these things we've listed down here, 1 being most like the matching pole, and 5 being most like the contrasting pole.</p>
14. Enquire.	Check for any unasked enquiry questions.

During the Discussion

Step	Action
15. Get the person talking.	<p>Start with the easy questions.</p> <p>How did you find having a dog in the classroom?</p>
16. Pick up markers as soon as you can.	<p>Make a note of passing references and come back to them.</p> <p>A few moments ago you mentioned ...?</p>

17. Use probes to delve deeper.
- Foster storytelling
 - Ask for illustrative examples
 - Give signs of interest such as a nod
 - Probe for feelings as well as facts
 - Can you tell me about how you were feeling when...?

18. Listen to what is not being said.

Close the Discussion

Step	Action
19. Thank the person	Thanks for efforts and time during this discussion.
20. Explain the next steps	If you've got any questions, or you think of anything else that you'd like to add, please let me know.

APPENDIX F: ENVIRONMENTAL CONTEXT OF THE RESEARCH

The framework for this research adopted a phenomenological perspective and ethnographic approach that emphasised the study of the culture of the students, teachers and dogs in a naturalistic environment. This environment included the micro-environment constituted by the classroom, the mezzo-environment constituted by the training provider and the course, and the macro-environment operating outside of the classroom constituted by the broader socio-cultural context of the location where the research was conducted.

Lincoln and Guba (1985) suggest that an important element in establishing trustworthiness of this research is transferability, that is, the extent to which the inferences of the research can be applied to other contexts. To establish transferability, Lincoln and Guba (1985) argue that the burden of proof lies with the researcher to provide sufficient descriptive data for the reader to make judgements about the applicability of the research to other contexts. To answer the question of transferability that is needed to address the applicability criterion for establishing trustworthiness of the research, it is important to examine the macro-, mezzo- and micro-environments within which the research was conducted.

Macro-Environment

The research was conducted in a major regional centre in northern Australia referred to as Hamptonville that enjoys a lifestyle and culture that is influenced by a tropical seaboard location. At the time of the research, Hamptonville had a population of just over 95,000 that was made up of 50.70% male and 49.30% females (Australian Bureau of Statistics, 2009). A large section of Hamptonville's population were born in Australia (79.4%) and 87.4% spoke only English at home (Australian Bureau of Statistics, 2009). Hamptonville had a relatively young

population with 42.8% of people aged between 25-54 who shared a median age of 34 years (Australian Bureau of Statistics, 2009). Hamptonville had a high employment rate with 95.7% of people employed either full time or part-time as: professionals, clerical or administrative, managerial or sales (53%); technician, trade workers, labourers or machinery operators (33%); or as community and personal service workers (14%) (Australian Bureau of Statistics, 2009). In 2006, Hamptonville's median individual income was \$529 a week or 13.5% above the national average (Australian Bureau of Statistics, 2009). At that time 77.7% of people lived in houses and 19.6% lived in apartments (Australian Bureau of Statistics, 2009). Additionally, 35.9% of all dwellings were rented (Australian Bureau of Statistics, 2009).

In Hamptonville at the time, the retail trade sector was the largest employing industry (14.7%), followed by health and community (11.5%), government administration and defence (11.1%), construction (10.1%), manufacturing (8.7%), property and business services (8.6% and education (8.0%) (Stateland, 2009).

In 2006, there were a total of 23,611 families in Hamptonville, of which 41.1% were coupled families with children, and 49.78% of the 34,137 households had a dog (Australian Bureau of Statistics, 2009; Ryan, 2010). Hamptonville had a registered dog population of 35,000 and was home to 4.41% of the state's total dog population of 794,000 (Australian Companion Animal Council, 2009).

Hamptonville had almost twice as many dogs as children (18,245 children under the age of 14), and a high proportion of both dogs per family (1.48 per family) and density of dog population (36.84 dogs per 100 people) (Australian Bureau of Statistics, 2009; Ryan, 2010). This compares favourably with the national average of 37.3% of families who own a dog, and the national average dog population

density of 18 dogs per 100 people. It is also consistent with research by Headey (2006) that suggests pet ownership in Australia is more prevalent in regional and country areas than in metropolitan centres. Whilst there is little research available on the size and breeds of dogs favoured by families in Hamptonville, the Australian perspective shows that small to medium size dogs are the most prevalent and are found in 82% of households (Headey, 2006). Larger dogs such as Labradors and German Shepherds are found in only a small number of households (Headey, 2006).

Mezzo-Environment

Two private training providers in the Hamptonville area were approached to participate in the research. Initial consent was gained from one organisation, however this was withdrawn before the research commenced. The remaining organisation failed to respond to correspondence and so a further private training provider, referred to as Hamptonville Community Training was approached and consented to participate in the research. At the time of the research, Hamptonville Community Training operated as a private psychological counselling business, and had recently expanded its services to include the delivery of accredited training. As well as the *TAA40104 Certificate IV in Training and Assessment*, Hamptonville Community Training also offered accredited courses in the areas of mental health and community services. Hamptonville Community Training was not accredited as a registered training organisation under the Australian Quality Training Framework. However it delivered accredited training under a co-provider agreement with a registered training organisation in another state. Hamptonville Community Training advertised the *TAA40104 Certificate IV in Training and Assessment* through the local newspaper and by using street-front signage. It charged participants a one thousand dollar fee to complete the full *TAA40104 Certificate IV in Training and*

Assessment qualification and a smaller fee for those attending only the upgrade component.

Hamptonville Community Training was located on a main road next to a railway line in an inner city suburb of Hamptonville and was owned and operated by Tanya, a qualified psychologist in her early 40s. Tanya had offered and delivered the *TAA40104 Certificate IV in Training and Assessment* on only a few occasions prior to the research, and had recently refitted her offices to accommodate a larger training room. The building in which the training room was located also accommodated a small reception area, and office space at the rear that shared doors leading into the training room. The building also housed two small counselling rooms and a kitchenette that was located behind the reception area. Leading out from the kitchenette at the rear of the building was a partially covered amenities area set with tables and chairs for use by staff and students during breaks.

Tanya employed a small number of staff that included several qualified psychologists, her son Johannes who was in his mid-twenties and managed the information technology needs of the company, and two female administrative staff, Sarah and Narelle who were both in their early twenties.

Within the context of the vocational education and training sector in Australia are Training Packages that, as part of the Australian Quality Training Framework, detail the standards for courses that make up part of the Australian Qualifications Framework. The course selected for the context of this research, the *TAA40104 Certificate IV in Training and Assessment* came from the *Training and Assessment Training Package*.

This course was selected because it was conducted using classroom-based instruction and was available over a short duration. Additionally this course was

representative of the classroom-based training within the vocational education training sector and was available through a number of registered training organisations within which the local area within the researcher resided. Furthermore, this course attracted participants who represented practitioners across a range of industries and focused on education within an adult setting, which was seen as complementary to the focus of this research.

At the time of conducting this research study, the *TAA40104 Certificate IV in Training and Assessment* was the entry-level qualification required for practitioners to deliver and assess accredited training in the vocational education and training sector and comprised 14 competency outcomes that are detailed at Table F1 (Department of Education Employment and Workplace Relations, 2007b).

The *TAA40104 Certificate IV in Training and Assessment* had recently superseded the previous entry-level qualification, *BSZ40198 Certificate IV in Assessment and Workplace Training*, from the *Business Services Training Package*. Under the rules of the *Training and Assessment Training Package*, holders of the previous *BSZ40198* qualification were given equivalent status for the first six competency outcomes and were required to complete an additional eight competencies in order to upgrade their qualification to the new *TAA40104* qualification (Department of Education Employment and Workplace Relations, 2007b). Consequently, Hamptonville Community Training offered courses specifically tailored to practitioners seeking to upgrade their existing qualification.

Table F1

Competency Outcomes

Competency code	Competency title
TAADEL301C	Provide training through instruction and demonstration of work skills
TAADEL401B	Plan and organise group-based delivery
TAADEL402B	Facilitate group-based learning
TAAASS401C	Plan and organise assessment
TAAASS402C	Assess competence
TAAASS403B	Develop assessment tools
TAAENV401B	Work effectively in Vocational Education and Training
TAAENV402B	Foster and promote an inclusive learning culture
TAAENV403B	Ensure a healthy and safe learning environment
TAADES401B	Use Training Packages to meet client needs
TAADES402B	Design and develop learning programmes
TAADEL403B	Facilitate individual learning
TAADES404B	Facilitate work-based learning
TAAASS404B	Participate in assessment validation

Micro-Environment

Hathaway (1988) and Lewis (1977) argue that elements of the physical classroom can have an impact on student behaviour by inhibiting or eliciting behavioural and emotional responses. These elements include the use of space, density and over-crowding, the layout of tables and chairs, the placement of

equipment and cables, lighting and heating, and egress and access ways. Therefore, this section will describe the physical configuration and layout of the training room where the course and the research were conducted.

The physical configuration and layout of the room depicted in Figure F1 shows two pairs of long tables that were placed opposite and slightly apart from each other, and an additional long table placed at either end. This table arrangement was placed obliquely to the orientation of the room, and abutted one side. Against this side was an additional table and a series of book cases that created a slim and cramped access way for students and teachers. At the front of the room, the end table was set up as part of the teaching space. On this table was placed a laptop computer, a printer and several piles of folders and papers. Between the two pairs of long tables was placed a stand on which sat a projector that shone an image of the teacher's computer onto the screen behind the teacher's desk. Beside the screen was a whiteboard that was placed obliquely against the front corner of the room in front of a stand that held a television.

The four-legged student chairs were constructed of rigid plastic and were arranged three to each table. This provided a small space of approximately six inches between each chair. On the desk in front of each student seat was placed a laptop computer with an accompanying mouse and keyboard. This equipment was packed up each night to accommodate another class and was laid out each morning in the original configuration.

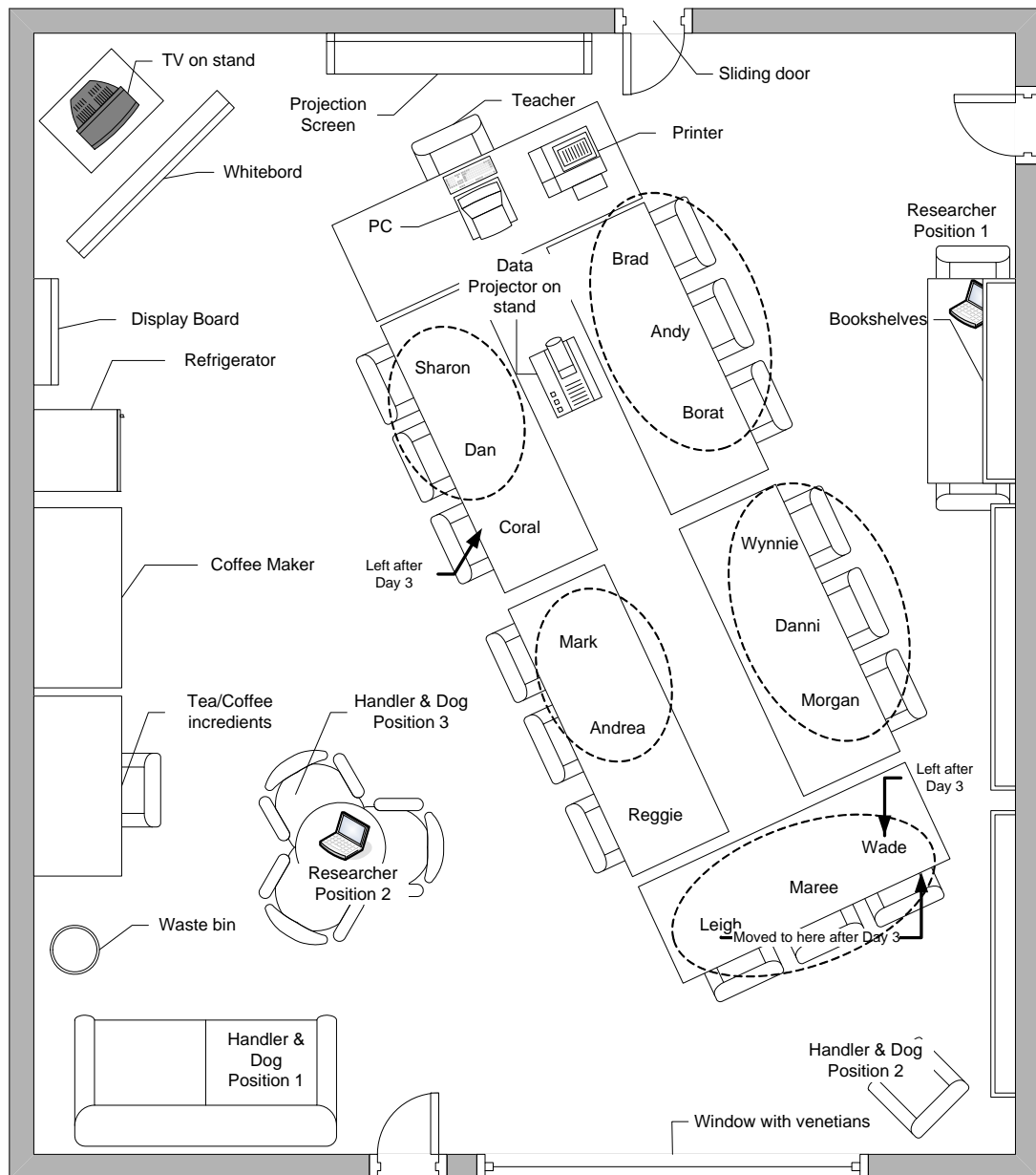

Figure F1. Training room layout configuration.

Each computer had several cords attached that hung over the end of the tables and led to the centre of the desk arrangement where they were connected to a lead that rose to the ceiling. Individual student space on the desks was limited and there was only enough space between each computer for a mouse. There was no space available for students on which to place folders, notepapers or other items. Students consequently either balanced these on their laps, or placed them on the floor next to

them or on desk space behind them.

Against the wall opposite the arrangement of student tables was placed a small refrigerator, a water cooler, a series of tables that accommodated tea and coffee making facilities, and a user-pay coffee machine. Towards the rear of the room was an open space between the arrangement of student tables and the refreshment facilities. In this space was placed a small circular table around which was arranged three student chairs.

There were three access doors into the classroom. At the front of the room was a swing door that opened to the reception area. At the front of the room behind the teaching space was a sliding door that opened into an office area. At the rear of the classroom was a glass swing door that led directly onto a small car park. Next to the rear exit door, against the rear wall of the classroom, was a small two-seater sofa. The only window was at the rear of the room, which looked onto the small car park.

APPENDIX G: SAMPLE INTERVIEW ANALYSIS

Transcript—Reflection	Code
<p>RESEARCHER: I just wanted to catch up with you about a couple of things, and just get your thoughts on a couple of things.</p>	
<p>CORAL: Yes, okay.</p>	
<p>RESEARCHER: That have happened. One in particular that I was interested in finding out a little bit about was Adonis and the barking incident, when the dogs walked past.</p>	
<p>CORAL: When was that? Oh.</p>	
<p>RESEARCHER: In the morning.</p>	
<p>CORAL: Yes.</p>	
<p>RESEARCHER: What were your thoughts, what, on what happened then?</p>	
<p>CORAL: I don't think I was thinking about what happened then.</p>	
<p>RESEARCHER: Okay, 'cause it was quite a loud bark, and sort of a lot of activity there.</p>	
<p>CORAL: Well, I'm used to dogs barking. Truly you've really got to stay pretty focused.</p>	
<p>RESEARCHER: Uh-huh.</p>	

Transcript—Reflection	Code
<p>CORAL: On the delivery. So the dogs haven't really impacted that much I don't think. You've just got to stay focused on what you're doing.</p>	
<p>What is interesting here is that she was focused on the course to such an extent that she was unaware of the actions of the dog, and her expressed need to, "stay focused on what you're doing." What is also interesting is that she does not mention the impact that it may have had for other people, only herself. What is also interesting is that the story started with a discussion about the dog barking incident, yet ends with her need to stay focused on the course.</p>	<p>Content focused. Non-distraction. Situation awareness.</p>
<p>That is interesting because it emphasises how her focus was turned inward to her own concerns to such an extent that if she was unaware of the dogs behaviour, she was possibly unaware of the behaviour and concerns of other people as well. The need to stay focused may imply the difficulty she may have been experiencing with the content and the delivery. It is also interesting because she does not display concern or empathy for others either in regard to the impact of the dog, or the difficulty that others may or may not have</p>	

Transcript—Reflection

Code

been having with the course.

I am interested in that because Coral appears to place greater importance on focusing on the content of the course, which she implies is difficult, rather than her surroundings and this may be evidence of the desocialising impact that the delivery, and the content itself may have had on Coral and possibly on other people. It also may indicate an egocentric view of the learning experience.

RESEARCHER: Okay so, really your attention wasn't diverted when that happened?

CORAL: No, I think one of the dogs barked behind me at one stage and I got a bit of a surprise, it's just that sudden loud noise. I'd seen those other dogs outside.

RESEARCHER: Uh-huh.

CORAL: So I knew there were other dogs around.

RESEARCHER: Right, and did you expect anything would happen?

CORAL: I don't know, I didn't give it that much thought actually.

Transcript—Reflection	Code
<p>What is interesting here is that she was aware of the dogs outside, but did not consider the impact or consequences. What is also interesting is that she does not see the barking as a significant impact, that is, didn't distract her, but rather was merely an unexpected loud noise. It is also interesting that she didn't give it that much thought.</p>	<p>Non-distraction. Low. impact/consequence.</p>
<p>That is interesting because I would have expected annoyance at being distracted from such a focused effort and attention on the course and delivery. It is also interesting that her attention was so focused that whilst she may have been somewhat aware of the other dogs, she did not divert her focus from the content enough to consider the impact. This may indicate that she was more concerned about her own immediate needs of focusing on the course content, than of the consequences of the dogs on other people, or even herself. It is interesting that she did not give it much thought, because that may indicate that it was not important to her, and therefore she may have not considered it as being important for other people.</p> <p>I am interested in that because it may reveal that Coral</p>	<p>Tightly focused/driven.</p>

Transcript—Reflection	Code
<p>is very task focused and centred on her own needs (egocentric), rather than what is going on around her and the needs of others. It may also reveal that the incident and the barking were not of any real significance to Coral, being neither a distracter nor contributor.</p>	
RESEARCHER: Okay.	
<p>CORAL: Yes, I thought it was a bit of fun, that these other dogs were like coming here and there was a dog here, it was like, “Oh, this is now the place where the dogs come.” I thought was actually quite funny, but I must have been trying to get the printer to work or something, because I was in the office and I was outside. Or maybe it was morning tea-time, I can’t remember. For some reason I was in the office, so I saw the other dogs.</p>	
RESEARCHER: Hmmm, okay. What about when Adonis...	
CORAL: Are you asking me if I’d like to have barking dogs in a training situation?	
RESEARCHER: No.	
CORAL: Probably not, [laugh] but since it did	

Transcript—Reflection	Code
<p>happen, it didn't matter.</p>	
<p>What is interesting here is that Coral saw having more dogs in the room as being fun and amusing.</p>	
<p>That is interesting because again, whilst Coral saw it as amusing and fun, she does not consider the needs of others, or see anything wrong with having strays in the room. It is also interesting because she does not mention the teacher's reaction or how the teachers responded to the situation, or consider the impact it may have had on others. She also could not remember exactly what she was doing at the time, which shows a low level of situation or self awareness.</p>	<p>Amusing – superficial, funny but not fun. Situation awareness.</p>
<p>I am interested in that because it may reveal how Coral had contributed to her own isolation from the rest of the group by being egocentric. It may also reveal that Coral does see any negative impacts that such incidents with dogs may have in the room, and conversely sees them as fun and amusing, although this was only on a personal rather than a social level, that is, being personally funny, but not adding to the emotional climate.</p>	<p>Lack of concern for consequences e.g., health and safety, Reggie, trainer of course. No mention of others. She doesn't mention it as a bad thing.</p>
<p>RESEARCHER: I'm just really interested to hear what</p>	

Transcript—Reflection	Code
people were doing at the time, what they were thinking at the time, how they saw other people's reaction.	
Didn't affect you at all? Okay.	
CORAL: No, I don't think so.	
RESEARCHER: What about when Adonis was playing underneath, he was walking sometimes.	
CORAL: Oh, that was alright. I mean, I think it's very challenging this set up.	
RESEARCHER: Yes.	
CORAL: So obviously the dog can't be there, and that's problematic because it would have been much nicer if the dog could've just wandered around like that. That was actually quite desirable I think. Having a dog in a corner that you can't see, seems kind of pointless, really.	
RESEARCHER: I agree.	
CORAL: So that was fine, except it became a bit of an issue with the electricity, and so you had to kind of be distracted in order to keep the dog out.	
RESEARCHER: Uh-huh.	
CORAL: So that was a distraction, which probably wasn't welcomed. But actually having the dog	

Transcript—Reflection	Code
<p>wandering around was nice, yes. But the responsibility part of it was tricky.</p>	
<p>What is interesting here is that she would have liked the dog to be wandering around more, but that the layout of the room prevented it, and this meant that the dog was wandering under the tables, which she saw as a slight distraction because of the responsibility to keep the dog away from the electrical cords. What is also interesting is that she does not indicate why the dog had to be kept away from electrical cords, whether it was the risk to the dog, or risk to the property, or risk to other people. What is also interesting is that she perceives a dog sitting in the corner as being, “pretty pointless,” Also she assumed responsibility for the dog’s behaviour in keeping him out, which was never implied or explicitly stated, and contradicts the established role of the animal handler that was in the room. Is this an emerging social norm that people assume some level of responsibility for the dog’s behaviour?</p>	<p>Movement as desirable. Added student responsibility for dog’s behaviour as burden. Student assuming responsibility for dog’s behaviour. Restrictive room layout. Negative framing: Problematic, can’t be there, responsibility, pointless, issue, distracted, keep the dog out, tricky, distraction, unwelcome. Visual contact with dog as valued.</p>
<p>That is interesting because she is conveying here a meaning and value through the activity of the dog, “wandering around,” that places more inactive dogs as,</p>	

Transcript—Reflection	Code
<p>“pretty pointless,” from her frame of reference. She also does not see that even though a dog may appear inactive, that it could be comforting or contributing to the climate for others. That is also interesting because whilst she preferred the activity of the dog, “wandering around,” she was not positive in accepting the responsibility that such activity may bring.</p>	
<p>I am interested in that because it may reveal the attractiveness of the activity of dogs, and that Coral is looking for more immediate and observable benefits of having the dog in the room. This may reveal itself as a pattern or contradiction amongst other people who see inactive dogs of less value than active dogs. I am also interested in that because of what it may reveal about people’s acceptance of responsibility for the dog in the room, and how concern (or lack of) for an animal through acceptance of responsibility for their safety or welfare may (or may not) generalise towards other people.</p>	
<p>RESEARCHER: Yes. Why is it nice to have the dog wandering around, for you?</p>	
<p>CORAL: Pleasant I suppose. It’s just like, you</p>	

Transcript—Reflection	Code
<p>know, if the windows got open [laugh] and you could be part of the outside world.</p>	
<p>RESEARCHER: Uh-huh.</p>	
<p>CORAL: It brings normality into the training room, I suppose. But having said that, it doesn't, I didn't think I expected perhaps, or perhaps you were looking for more positive responses. Whereas because everyone's focused on this, if it was a workplace, where you were just doing your normal work, and you weren't having to concentrate, because there's a huge volume of work which not necessarily everyone is aware of how much, of what we're skimming across the top of a pretty big iceberg. And so you don't want to miss anything because later in the workplace that detail will become important even though it may not have seemed significant enough here. So I suppose I was pretty focused on that. Whereas if it was my workplace I'd, working at my desk writing lesson plans, or writing up records or something, and there was a dog wandering around, I'd probably pay a lot more attention to it.</p>	
<p>RESEARCHER: Right.</p>	

Transcript—Reflection	Code
<p>CORAL: And would think that that was a really nice part of the workplace, if you know what I mean.</p>	
<p>What is interesting here is that she mentions the dogs brings a sense of normalcy, “everydayness” into the classroom, likening it to opening a window and letting the outside world inside, being able to be part of the outside world, rather than removed from it. What is also interesting is that the story then moves onto how she assumes that everyone else is the same as her, and is focused on the large workload of the course, that she believes people are not aware of. It was her perception that people were focused, whereas at the time, at least one (Wynnie) was asleep because people were reviewing documents and doing research on their own, or were distracted by the laptops looking up various websites and so on. Other people are unconsciously incompetent about the huge volume of work, the tip of the iceberg. In other words, they do not know what they do not know. Whereas Coral is aware of what she does not know, or needs to know which may contribute to her anxiety levels.</p>	<p>Being part of the outside world.</p> <p>Training room is not a normal environment.</p> <p>Workplaces are normal environments.</p> <p>Training is seen as more difficult than just normal work.</p> <p>Normal work is seen as easier than training.</p> <p>Because training is more difficult than normal work, you need to focus and concentrate more.</p> <p>You can’t pay attention to the dog when you have to concentrate.</p>

Transcript—Reflection

Code

That is interesting because her perception of the size of what the course is attempting to cover may be over estimated, and she again stressed her focus on the detail because you do not want to miss anything because that detail will be important later. This may be based on her previous experience in applying similar learning back on the job previously. That is also interesting because she sees a positive value in bringing the outside world in, like opening a window that implies the classroom may be sterile or cut off or unrelated to the real world, a false environment. That is interesting too because she believes people are unaware of the size of what they are trying to get through, which may or may not be true, and that the size she perceives the workload, also may not be accurately formed.

I am interested in that because she may be making more out of the course by building it up to be a large amount of work with serious consequences in the detail, and creating an understanding that is not there. The course is to make trainers, not directors or auditors of RTOs. So maybe she is placing more importance on the course, and therefore has conflicting expectations of

Transcript—Reflection	Code
<p>the course outcomes. I am also interested in how the dog can bring the outside world inside and create a pleasant experience as it may reveal what is perhaps lacking in the learning environment, and an implied need amongst this student.</p>	
RESEARCHER: Okay.	
<p>CORAL: Whereas I don't think this is actually the greatest situation for interacting with the dog, or even appreciating the fact that the dog is here, as much.</p>	
<p>RESEARCHER: I'd have to agree because the layout of the room is far.</p>	
<p>CORAL: Yes, it's very exclusive too.</p>	
<p>RESEARCHER: From ideal, and...</p>	
<p>CORAL: But also the conditions of really needing, the conditions of the amount of work that people are trying to cover in a very short time. You know, you don't have slack off time, where it's nice to look around and see where the dog is, and pat it, if you know what I mean.</p>	
<p>RESEARCHER: Yes, you have to be fully focused.</p>	
<p>CORAL: Yes, even though it might not seem like that, if you, I'm sure you know when you're doing</p>	

Transcript—Reflection	Code
<p>assessments and stuff and the sort of record keeping that you have to do, you always have to keep thinking about all the other things we're not talking about. Making a mental note of how this will apply to what you know you have to do in reality, which is much more, much greater than this, and you just have to keep remembering these tips to apply to that. So yes, I think you do have to be pretty focused. So poor old doggy is not a big part of the scene. Having said that, yes, it's very pleasant having the dog around, yes.</p>	
<p>RESEARCHER: Well, that's good to hear.</p>	
<p>CORAL: Sure, I mean, I like dogs, so why wouldn't I say that?</p>	
<p>What is interesting here is the way she sees the room layout as not supporting the presence of the dog, and that she's sees it as exclusive. What is interesting here is that she interleaves and re-emphasises the amount of work that is being covered, that does not provide time to interact with the dog. What is also interesting is that she mentions having to keep thinking about the things we are not talking about. What is interesting also is that the dog is not a significant part of the scene for Coral</p>	<p>Physical layout erodes value of dog Physical layout impedes interaction with dog Exclusive environment Environment: physical workload, time Dog interaction and observation reserved for</p>

Transcript—Reflection	Code
<p>and that the course content, or perceived difficulty of the content overwhelmed the presence of the dog. She also describes herself as a dog person, even though she does not make time to play with the dog. Focus on course content is superordinate to all other things happening in the class, not just the dog, as she makes not reference to other people. I like dogs justifies why I believe they are pleasant to have around. What is implied by, “why wouldn’t I say that?” Perhaps I should answer that question.</p>	<p>slack off time. Subordinate pleasant to have dog around.</p>
<p>That is interesting because she does not provide any indication of what she means by exclusive. That is interesting because other people did not perceive the workload to be that onerous, and many found opportunities to pat the dog, and to interact with the dog. That is interesting because it may show that she has a great deal more experience and knowledge than the course is offering, and that her learning expectations may not be being satisfied.</p>	
<p>I am interested in that because it may reveal that the course content is not simplified for its delivery and that the instructional techniques and teaching style are not</p>	

Transcript—Reflection	Code
<p>helping people understand the content, making it an onerous task, and that such an onerous task requires focused attention that does not permit time to interact with the dog. For Coral the dog is not a significant addition to the room, even though she says it is very pleasant having the dog around. I am also interested in that because other people did not perceive her as a dog person or liking dogs because she did not make time to play with the dog. It may also reveal something about the power structures within the room, that are represented by the powerlessness of the student to control her situation in the face of what she perceives to be overwhelming content in a short period of time, in an inappropriate room layout.</p>	
<p>RESEARCHER: You think it's have an affect on others, do you notice a reaction from other people?</p>	
<p>CORAL: I don't know, I mean is it Mark beside me, he obviously loves dogs. I mean, he's calling the dog, and he's inviting the dog, yes. I don't know really. I haven't noticed anything. Well you don't see, you can really see other people.</p>	
<p>RESEARCHER: You can't see?</p>	

Transcript—Reflection	Code
CORAL: I can really only see the people on each side of me, and with the laptops up...	
RESEARCHER: Because everyone's blocked out by laptop screens?	
CORAL: I can't see what's happening there.	
RESEARCHER: Hmmm.	
CORAL: I mean you're flat out. And I am actually, one of the reasons I'm focusing, is I'm actually finding it quite difficult to read the OH, the screen.	
RESEARCHER: Yes.	
CORAL: So, yes, you are pretty focused.	
<p>What is interesting here is that whilst she starts talking about Mark who loves dogs, and his behaviour, she does not perceive any affects of the dog on other people, which she attributes to not being able to see across the desks because of the laptops. Revealed here is that part of Coral's anxiety and close focus is the lack of visual acuity in clearly reading the large screen. Observed behaviour influences perception: if he calls or invites the dog and pats him, he obviously loves dogs. This implies if you pat dogs and call them over you</p>	<p>Laptop as physical barrier to visual contact with students Focus: Visual strain in reading large screen Large screen as artifact Laptop as artifact with latent affordance: physical barrier between student.</p>

Transcript—Reflection	Code
<p>love them, and it also implies the opposite, if you do not call them over or pat them, you do not love them, or if you do not love them, you will not call them over or pat them. Why is this obvious?</p> <p>That is interesting because she does not mention Dan who was sitting on her other side, and Sharon who were both patting, and calling the dog also. It is also interesting because she piggy backs this thinking and reflection, with her difficulty in reading the projection on the screen and her ability to see what other people around the room are doing or reacting. She also does not mention the people who were coming over to get cups of coffee or the behaviour of people during the breaks with the dogs.</p> <p>I am interested in that because again it may reveal the power structures represented through the powerlessness of the students over their ability to see and view others, and view the screen.</p> <p>RESEARCHER: Hmmm.</p>	
<p>CORAL: So yes, there's not much time to look around and see what the dog is up to. Yes, which is a shame, because it's quite interesting just observing</p>	<p>Time as part of the physical environment</p>

Transcript—Reflection	Code
<p>dogs or, and any animal behaviour.</p>	
<p>RESEARCHER: Yes.</p>	
<p>CORAL: So if the dog was somewhere that was well within your line of vision, you'd probably be quite interested, it would probably be like having one of those desk toys and things that you get at conferences.</p>	
<p>RESEARCHER: Ahhh, okay.</p>	
<p>CORAL: Where you can muck around with something, you know. Looking at the dog doing that, and listening to other things coming in would probably be more complimentary.</p>	
<p>RESEARCHER: Hmmm.</p>	
<p>CORAL: So I think a different scenario is what you're after.</p>	
<p>What is interesting here is that she mentions there's not much time to see what the dog is up to, rather than the physical barriers. What is also interesting is that she sees it as an interesting and stimulating thing to do, to observe animal behaviour. She also mentions convenience, that is, the dog being in an easy line of vision, would encourage interest in the dogs activities, rather than taking responsibility or exercising</p>	<p>Dog as visual artifact. Observing dogs as appealing. Observing dogs like watching novelty toy.</p>

Transcript—Reflection	Code
<p>individual power to move around and change the physical setting to her own advantage. It is also interesting that she likens the interest in the dog's behaviour to that of a conference toy. Different visual stimulation as complementary to aural messages.</p> <p>In what ways can this be complementary? Is this like “zoning out” when watching a toy, where that part of your brain runs in neutral to increase aural acuity? Like doodling when listening, aids in thinking and retention?</p> <p>That is interesting because it may reveal something about the power of the student in changing their environment, which they may see themselves as powerless in terms of both time and physical layout.</p> <p>This is emphasised by the convenience of having the dog in easy line of site, rather than the student having or being able to exercise control. Likening the role that the dog plays to that of a conference toy is interesting because it may reveal how this student constructs the role of the dog in the classroom.</p> <p>I am interested in that because it may reveal the power hierarchy of the student in the room, as well as the construction of the role of dog as mediating artifact as</p>	

Transcript—Reflection	Code
an item of interest similar to a conference toy. I'm also interested in that because a student's power may not only be over the physical layout, but also the style of teaching by organising their own time and pace during the learning.	
RESEARCHER: Yes, I'm going to have a go and see what I can do about the cords on the floor, to lift them up.	
CORAL: Yes, but even so, even if the cords weren't there	
RESEARCHER: It is still difficult.	
CORAL: You can't just, there's almost not visual.	
RESEARCHER: Yes.	
CORAL: In fact, and you do get pretty uncomfortable on these chairs after a while, so. People aren't exactly [inaudible] [laugh]. Maybe they are. They probably will be by next week. The people here for the ten days or whatever start to slip into kind of a groove, and they will become more chummy and stuff. And maybe the dogs will kind of slip into that a bit more.	

Transcript—Reflection

Code

RESEARCHER: I'm hoping when we get away from a lot of this talking stuff, and it becomes a bit more active, that there'll be a bit more movement around the room.

CORAL: Yes, I mean even if you were set up. I mean I usually try to teach with a teaching space in there, so that I can actually go and interact directly with each student. And then see if the dog were there, and if you actually saw that. It's very interesting was technology's doing, it's really putting people into like a little universe, and little corral in the library. It's like you're in your own corral. It's fascinating.

RESEARCHER: And its one of the interesting things to note too, there's not a great, as you've mentioned, you've got the, you're looking up on the screen, you've got the barrier there of the laptop screens. You really can't see anybody else.

CORAL: There's not much interaction.

RESEARCHER: Very, very limited interaction.

CORAL: Yes, it's fascinating, isn't it? And yet, I think that's one of the keys to learning, to successful group learning.

Transcript—Reflection	Code
<p>RESEARCHER: Uh-huh.</p>	
<p>CORAL: Is that people interact with each other.</p>	
<p>RESEARCHER: It is, and that's one of my focuses is obviously to, is the social side of learning.</p>	
<p>What is interesting here is that she mentions the visual difficulty of seeing around the room, and how uncomfortable the seating is and how people are put into their own corrals created by technology that she perceives as a cause for the lack of interaction not only amongst people, but also with the dog. It is also interesting that she sees interaction as important to successful learning.</p>	<p>Uncomfortable chairs as part of the physical environment.</p> <p>Expectation of group dynamics.</p> <p>Laptop as artifact – socially isolating.</p> <p>Lack of visual connection with other students.</p> <p>Lack of student interaction.</p> <p>Desk layout and preferred teaching space.</p>
<p>That is interesting because again it may reveal the powerlessness of the student over their own environment and being desocialised in a group learning environment where social interaction is seen as an</p>	

Transcript—Reflection	Code
<p>important process. It is also interesting that the technology was seen as desocialising.</p>	
<p>I am interested in that because no one felt empowered to change their own environment or situation, and did not challenge the status quo, even though this student was very aware of what was happening through the technology and not being able to see. Why did this student, and others, not take ownership or control?</p>	
<p>CORAL: That'll happen a lot more, I think you'll get more data next week, I really do. But this is all, it's no comment on the training but this kind of flies in the face of good practice, I think.</p>	<p>Teaching paradox and irony not practicing the theory.</p>
<p>RESEARCHER: In what way do you say that?</p>	
<p>CORAL: Oh well, you know, how are we catering for individual learning styles here, you know?</p>	
<p>RESEARCHER: It's interesting, we're not, we don't seem to be practicing what we hopefully are preaching.</p>	
<p>CORAL: Oh, you picked that up [laugh].</p>	
<p>RESEARCHER: That thought's gone through your head as well?</p>	
<p>CORAL: It happens at almost every single training session you go to. You go to learn how to do it,</p>	<p>Expectation of innovation.</p>

Transcript—Reflection	Code
<p>not to, except I actually came here because I thought it was going to be innovative. I never thought it was going to be like this.</p>	Expectations unmet.
<p>RESEARCHER: Why is it that we throw, when we get in front a group we throw the theory of everything we know about teaching out?</p>	
<p>CORAL: It's because, no, the answer is simple. Huge volume of content to be delivered in a specified time.</p>	Economic imperative superordinate to good practice.
<p>RESEARCHER: So it's an economic debate.</p>	
<p>CORAL: The deliverer is trotting against the clock. And you can see that this afternoon. Actually who listens this?</p>	Fear of reprisal.
<p>RESEARCHER: Me, that's the only person.</p>	
<p>CORAL: Okay, I don't want any feedback.</p>	
<p>RESEARCHER: Oh no, no, no.</p>	
<p>CORAL: Because I would give different feedback.</p>	
<p>RESEARCHER: And that's part of my ethic considerations if you like.</p>	
<p>CORAL: Yes, yes, yes that's right.</p>	
<p>RESEARCHER: As researcher, because I'm obviously</p>	

Transcript—Reflection	Code
getting feedback about this course from individuals.	
CORAL: Yes, of course. But having said that.	
RESEARCHER: I can't pass that one.	
CORAL: Like, this is a friendly kind of thing, you can have a very unfriendly thing and stuff. Except that I actually came specifically to do this course because they promised an innovative approach.	Unmet expectations, promise of quality delivery not met. Learner as customer.
RESEARCHER: Right.	
CORAL: And I was very interested, because I'll probably end up delivering TAA and I was very interested to see how you get around beating the clock on that massive delivery of content. And I can't tell you, I was so depressed yesterday when I just saw they were stuck in the typical training scheme.	Motivational sub-plot: ideas seeking for professional practice. Unmet expectations: emotion (depression).
What is interesting here is that this student, who has had experience in practicing as an educator, has clearly formed ideas of what is going on, and recognises the incongruence between the content, that is, teaching people how to teach, and the method used, resulting in do as I say, do not do as I do. This student also sees the economic imperative of getting through the volume of content as superordinate to the purpose of transferring	

Transcript—Reflection	Code
<p>skills and knowledge, as something that is endemic within competency-based training. It is also interesting that this student reveals her concerns about who may listen to her comments, inferring that she would not convey the same feedback to those delivering the training.</p>	
<p>That is interesting because again it reinforces the powerlessness of the student over the whole environment, and her disappointment where she thought that this course was going to break the mould, which in her mind it didn't. Again her powerlessness in not being able to speak up against authority, or to even complain in order to improve her situation. She maintains her own oppression as a learner, fearful of reprisal by the voices of authority.</p>	
<p>I am interested in that because this student is clearly dissatisfied with the current economic drivers of competency-based training, and whilst she exercises control by selecting what she thought was an innovative course, became powerless again by the system when it failed to deliver on quality learning, in being able to do anything to challenge the status quo,</p>	

Transcript—Reflection	Code
<p>and also in voicing her concerns to the people who held the power.</p>	
<p>RESEARCHER: Yes, I was surprised that they were able to deliver it so quickly because I know that other companies are taking a lot longer to deliver it.</p>	
<p>CORAL: Well it's normally, it used to be, like it's longer than it was. It was the, Certificate Four WTA was eight sort of days. But there was not much break I can tell you.</p>	
<p>RESEARCHER: Hmmm.</p>	
<p>CORAL: They were very long days. But we were hammered. Like the pace here is leisurely compared with the volume of work. But that's because there's a lot we haven't done. And I just kind of hope everyone doing this actually realises they have, they'll get an audit and they'll be creamed if they haven't really followed things down to the absolute final detail.</p>	<p>Fear and threat of failure for others. Confused myth, fact, fear, unspecified consequences (creamed). Idle/false threat and fear through lack of understanding.</p>
<p>RESEARCHER: What's your reflection on the assessment that happened this afternoon?</p>	<p>Fear and threat for others? Why is this?</p>

Transcript—Reflection	Code
CORAL: I thought it was like, this is very difficult to have this conversation here.	Fear of reprisal
RESEARCHER: Okay. Maybe it's something we can pick up later.	
CORAL: In this, yes. I would have thought it was invalid. Honestly.	Critical of practice.
RESEARCHER: I agree with you.	
CORAL: I really would. And it worries me. Because I actually work for a different RTO and I put myself out on a bit of a limb by coming to do this, instead of doing it on line with them. Was it written in her contract that she couldn't study at another institution? What limb has she put herself out on?	Fear of reprisal. Risk taking. Fear of authority/oppression by other RTO?
RESEARCHER: Uh-huh.	
CORAL: And I've also paid for it myself.	Personal investment.
RESEARCHER: Hmmm.	
CORAL: Whereas I didn't have to do that. And I was really looking for best practice.	
RESEARCHER: So you're feeling disappointed?	
CORAL: I was pretty disappointed yesterday. I'm sort of philosophical today. And there's things I like about it. Like it's easy for me, it's just here [taps	Fear of reprisal. Contradictions – easy, but whole lot more

Transcript—Reflection	Code
<p>workbook]. But I know that there's a whole lot of stuff I'm going to have to re-do in order to reach the standards of my own RTO. And that ticks me off a bit. Actually I'm really concerned about recording this.</p>	work.
<p>RESEARCHER: I won't, this won't go absolutely anywhere.</p>	
<p>CORAL: I'm very concerned that we're recording this.</p>	
<p>RESEARCHER: Do you want me to turn it off?</p>	
<p>CORAL: Yes.</p>	
<p>[Tape turned off briefly]</p>	
<p>What is interesting here is that this student, based on previous experiences, focuses on the volume of the course content that she sees as challenging. She also sees the technical delivery as not meeting the standards to which the delivery should be complying. It is also interesting that she compares her current experience to previous experience as being leisurely pace. It is interesting that she sees this as disappointing and not meeting her expectations as she had assumed a personal or ethical risk by completing this training through a competitive organisation, and that she had paid for it</p>	

Transcript—Reflection	Code
<p>personally. She is also angry that she believes, based on her current experience that she will need to make further personal investment in order to meet the prescribed standard. It is also interesting again that she feels dominated by the authority through fear of recording negative comments that someone may hear. People do not get audited, organisations do, even then they get opportunities to rectify where things are not 100%.</p>	
<p>That is interesting because it may reveal a negative disposition towards the course, the trainer and provider, and disappointment and anger that the system has let her down when she sought enlightenment (best practice), that she now sees she will have to make further personal investment simply to meet the prescribed standard that she could have met by behaving ethically and doing the course their her own RTO.</p>	
<p>I am interested in that because it describes the context and environment within which the learning is taking place and the dog is being used as artifact. I am also interested in that because it helps understand the wider</p>	

Transcript—Reflection

Code

hierarchy and power struggles between the individual, the system and the people providing the training, which places the person at the bottom of the ladder, where in fact the people arguably should be at the top of the ladder as they are the reasons and the holders of the skills that the system is designed to train.

CORAL: What did you hope to achieve from having the dog?

RESEARCHER: I want to find out what happens when you put a dog in a mainstream classroom. We know a lot of things that happen in disabled classrooms, and people with learning difficulties, and so on. All sorts of things happen, you know, teachers use them as a subject of show and tell, or they have them there as a classroom pet. One lady in Melbourne just has them wander round a year seven class, and it's a lot more open than this, so there's a lot more engagement.

CORAL: And that's a mainstream year seven class?

RESEARCHER: Yes. But no one's looking at it with adults, and I did a similar set up to this a little while ago, and the room was decidedly different. It was like a

Transcript—Reflection	Code
big U-shape, so the dog was wandering around and would sit in the middle of the U and wrestle and play.	
CORAL: Yes, I think that's the kind of thing I'm saying you know. The opportunity, well it's really nice to be able to pat the dog, but to be able to observe, sort of unconscious kind of doggy behaviour is perhaps a relaxing thing or something, I guess. It's hard to know. It hasn't really happened.	
RESEARCHER: No, it hasn't. So I'll see what I can do with the cords, that might help a little bit. We won't have to keep pulling Adonis back all the time.	
CORAL: Yes.	
RESEARCHER: It is a difficult set up for what we're trying to achieve.	
CORAL: This other dog, whose name I don't know.	
RESEARCHER: Lady.	
CORAL: Lady, yes maybe I should have remember that. I guess she's not such an inquisitive or curious or interactive kind of dog. If you interact with her, she's happy with that.	
RESEARCHER: She's a different dog altogether.	

Transcript—Reflection	Code
CORAL: Yes, so.	
RESEARCHER: Less outgoing, she's more reserved.	
CORAL: Yes.	
RESEARCHER: She's older.	
CORAL: Yes. So I guess maybe she could kind of lie around and people would look at her.	
RESEARCHER: Hmmm.	
CORAL: Yes.	
<p>What is interesting here is that she mentions its pleasant to observe dog behaviour and interact with dogs, using the term “doggy” behaviour, or baby-talk, and that it is relaxing, though she uses the term, “I guess” implying that he is not committed to that opinion, and in some ways devalues her own statement. From her point of view it has not really happened, whereas earlier she states that it has at least for Mark, and for her to a lesser extent – at least the opportunity has been there, but she may not have taken up that opportunity. What is also interesting is that she says she should have remembered Lady's name, though we do not really know why. What is also interesting is that she sees Lady, though passive and reserved, useful in that she could be the subject of</p>	<p>Observing dog as pleasant. Baby-talk. Passive dog behaviour.</p>

Transcript—Reflection	Code
<p>observation, which Coral sees as appealing.</p> <p>That is interesting because she reinforces the appeal of observing dog behaviour, yet observing a passive dog, as she has mentioned before, has little value, and that it is more appealing to have dogs moving around. It is also interesting because it's the first time she's used baby-talk discussing the dogs, and using it with the term "I guess," could be seen as condescending or devaluing the statement that observing the dogs could be relaxing.</p>	Contradictions.
<p>I am interested in that because it may reveal that a passive role for dogs though observation, can be as appealing and rewarding (though in different ways such as relaxing, increasing aural acuity) for people as active roles.</p>	
<p>RESEARCHER: I'm not going to know what I find out until I lay all the data out in front of me.</p>	
<p>CORAL: But it might also be interesting, I read in your kind of abstract that you were interested in how it worked I think, for people who are getting back into the workforce or something. But you're not going to find that with this group.</p>	

Transcript—Reflection	Code
RESEARCHER: No.	
CORAL: These are all, you know focused workers.	
RESEARCHER: That's right, I'm not sure where that, I think that was mentioned a little bit in the press release. That was my supervisor who said that.	
CORAL: Oh, well that came on the email.	
RESEARCHER: Yes, and the press release should have. There was a quote in there about people returning to the workforce, which is not a hundred percent correct..	
CORAL: Well it's interesting, because those are the people who may approach something like this with kind of anxiety, and having a dog would be a release for that, and an element of normality and all sorts of things.	
RESEARCHER: Yes.	
CORAL: Whereas people here need that piece of paper in order to do their job, or in order to get a job, they're very focused. Whereas probably people coming back into the workplace after a long break have, may have self-esteem issues which you're probably not	

Transcript—Reflection	Code
going to find in this group.	
RESEARCHER: There's also people changing careers, who have to change careers for whatever reason.	
CORAL: Yes.	
RESEARCHER: Andy down the front there.	
CORAL: But they're pretty motivated.	
RESEARCHER: This group?	
CORAL: They're pretty motivated, yes.	
RESEARCHER: Hmmm.	
<p>What is interesting here is Coral sees everyone in the group as focused workers, and that people who are getting back into the workforce after an absence may approach a training course with greater anxiety than those who do are currently in the workforce, and that by implication are not focused. It is also interesting that she mentions that you will not find people with self-esteem issues in this group. What is also interesting is that she recognises that dogs would reduce anxiety and stress during the course, for those who experience it.</p> <p>Hidden marginalised people not recognised – Andy and Reggie were marginalised through disability, as was Borat through unemployment.</p>	<p>Group seen as mainstream focused workers with low anxiety, high self-esteem and motivation.</p> <p>Hidden marginalised.</p>

Transcript—Reflection	Code
<p>That is interesting because there were a variety of people in the group, not all focused workers. Borat was unemployed and others were trying to either change career direction or improve current career moves.</p> <p>Relieving stress and anxiety for people is a recognised contribution of dog/human interaction. That is interesting also because there is an assumption that “mainstream” groups do not experience self-esteem issues, and that by implication, will not gain the same level of benefit from having the dog in the class.</p> <p>I am interested in that because the stress relief of dogs reinforces established theory. I am also interested in that because it challenges our thinking of what a “mainstream” group is, and that mainstream may also be able to benefit from the dog in similar ways to marginalised in relieving stress, anxiety and enhancing self-esteem. I am also interested in that because the focus here for Coral is on the other students, at no time during the discussion does she mention what it might mean for the teachers to have the dog in the room, which we know helped relieve stress. We also know that there was at least one teacher who was perceived</p>	

Transcript—Reflection	Code
<p>as having low self-esteem or confidence, and that therein, ergo, the dog may have been able to provide a benefit to her.</p>	
<p>CORAL: Whereas if you, I reckon it would be interesting to insert an animal like that into, you know how you can get a group of students who are kind of switched off.</p>	
<p>RESEARCHER: Yes.</p>	
<p>CORAL: Especially if they are not on some government programme to come back or whatever. If they're for example, year twelve students or whatever and they're kind of going nowhere.</p>	
<p>RESEARCHER: Hmmm.</p>	
<p>CORAL: Passive resistance is their modus operandi, and they don't want to be [laugh] consulted on what's coming because they haven't got any plans for it and nowhere to go and they've acquired minimal skills through having this kind of approach for the last twelve years, for what ever reason.</p>	
<p>RESEARCHER: That's a good point.</p>	
<p>CORAL: Someone, putting a dog into a demotivated.</p>	

Transcript—Reflection	Code
RESEARCHER: Hmm.	
CORAL: Deliberately passive group.	
RESEARCHER: Hmm.	
CORAL: I think might be an extremely interesting group scenario.	
RESEARCHER: That's a very good suggestion.	
CORAL: Yes.	
RESEARCHER: And what I was trying to get at early in piece was, I wanted to move away from these therapy situations. You know, we've said, Yes, we know they overcome.	
CORAL: Yes.	
RESEARCHER: Difficulties in those respects.	
CORAL: But what you want it to have them actually switch on to learning, to engage in that.	
RESEARCHER: And that you've actually provided an idea to be able to look at an element of that mainstream society that can benefit from that kind of therapeutic intervention.	
CORAL: Hmm. Well, there's lots of those groups out there I can tell you.	
RESEARCHER: Yes.	

Transcript—Reflection	Code
CORAL: There really are.	
RESEARCHER: Okay, I won't take up any more of your time.	
CORAL: Oh, that's alright.	
RESEARCHER: Thank you very much.	
CORAL: No, you're welcome.	
RESEARCHER: You're here for tomorrow and that's your last day?	
CORAL: That's right.	
RESEARCHER: Right.	
What is interesting here is Coral offers suggestions as to where she sees there may be value in including the dog in the classroom, in traditional intervention ways with marginalised youth.	
That is interesting because she implies through use of language "whereas," that it would be of more value to have a dog amongst marginalised youth, that this was a mainstream group who were pretty motivated, and because there were no visible, apparent or perceived obvious problems, there was little real value in having the dog in the room.	
I am interested in that because it may reveal a running	

Transcript—Reflection	Code
<p>theme or counter argument that may raise its head from time to time. It raises the question, just because things may be less visible, pronounced or apparent amongst mainstream, are they of less value in addressing? I am interested in that because it may reveal that the needs of a group of people are not being met, and that is the silent marginalised people who are hidden within our construct of mainstream, that we do not need to do anything about them, or they are less important because there are people with more obvious issues, and so they remain marginalised in silence.</p>	

Thematic Discussion

Coral as an Island

Coral's single-minded content focus may have impacted her level of situation awareness, and awareness or concern for others. This places Coral very much as an isolated island within the room.

Content Focused

During the course, Coral felt pressure to, "stay focused on what you're doing." Her fears about missing the finer details of the course may stem from her professional role in delivering training for a registered training organisation, and the potential for audit, saying, "they'll be creamed if they haven't followed things down to the absolute final detail." This is not the case, as all audits reveal are deficiencies

against standards, which need to be rectified; so this appears to be a hollow fear. Or is this somehow tied up with power and control issues?

Coral was very enthusiastic in the way she describes the ‘huge volume of work, that not, “everyone is aware of,” that she fears people will miss the important detail that will come back to haunt them when needed in the real world, and the short time in which to cover it that leaves no, “slack of time where it’s nice to look around and see where the dog is, and pat it.” For Coral, the training was an artificial world that was hammered with volumes of work, a multitude of critical detail hidden amongst the volume, all delivered at a cracking pace that allowed no latitude. Little wonder then, that she didn’t interact a great deal with the dog. Creating herself as an island in this way, Coral didn’t interact with any other student, and only with the teacher in a dominant, conflicting manner, possible through fear that she wouldn’t get through all the work, or would forget key details later.

Situation & Consequence Awareness

The dog however barked behind her, and surprised her because of the sudden loud noise, even though she says that she is used to dogs barking, and was aware there were other dogs around. However, she does not mention what exactly she was doing at the time of the incident, and appears confused saying, “I can’t remember.” Whilst she was aware there were other dogs around, she did give it much thought as to their behaviour, or the predictability of their behaviour.

Awareness of & Concern for Others

Mark and Andy are the only people she mentions by name. She also thought that it was a bit of fun and that it had changed the environment to one where, “this is now the place where the dogs come.” What is interesting here is that in recalling

this event as fun, she ignores the special needs of those non-dog people in the room, the woman who was allergic to dogs, the teachers in managing the class, and the health and safety of both the dogs, and the people through having strays in the room. This shows a lack of concern for others. She did however, express concern for Adonis playing underneath the tables where, “it became a bit of an issue with the electricity, and so you had to kind of be distracted in order to keep the dog out.” However this appears a generalised concern, and not specific to students, teacher, dog or equipment.

Coral’s perceptions of the group, others, workload during the course, motivations and so on are incongruous with what was actually occurring. On very few, occasions does Coral mention other students or the teachers during her discussions of the dog barking event, or the impact of the dog. Whilst she may have been unaware of what was happening around her, she was aware that Mark, who was sitting next to her, was interacting with Adonis by calling him over and inviting him. However, she was unaware or did not mention Dan and Sharon’s interactions with the dogs that were similar (they were sitting on the other side of Coral).

Distraction – Non-Distraction

For Coral, the appropriate time to interact with the dog, and pat it, look around and see where it is, is “slack off time.” She did not feel she had any “slack off time,” yet this did not stop most others from using the laptops to discretely distract themselves and create their own time.

Coral describes two other real distractions for her (the others being qualitative and quantitative workload and time pressure); the laptop screens that blocked her visual connection with those seated opposite her, and difficulty in

reading the image projected on the display screen at the front of the room (Reggie also evidenced this through observations).

Value of Dogs

She defines Lady as not as inquisitive, curious or interactive as Adonis, and suggests that her passive role may have value for people to observe animal behaviour. Coral had set ideas on how a dog could be used in a classroom, that is, people re-entering the workforce to improve self-esteem or disengaged youth as a way to motivate. Both of which she did not believe existed in the course group. This again raises the hidden marginalised amongst the mainstream, as there was no basis for this perception. She mentions that the people in the course were pretty motivated (though other evidence conflicts with this), saying that people here need that piece of paper in order to do their job, and they were very focused.

Even so, she did not believe that the dogs had impacted that much, though this was an unqualified generalisable “truth” that is not supported by other evidence, and indicates further in the discussion that impacts may not be as overt or directly observable as first thought.

It is possibly because of this superordinate concern with concentrating on the volume of work, and the physical layout of the room, that for Coral does not really represent the best situation for appreciating or interacting with a dog.

She liked having the dog around, it was pleasurable, but the abnormal demands of the training room, both physically and intellectually, meant that she did not have the time to interact with the dog possibly as much as she would have liked to. In condescending terms she describes that, “poor old doggy is not a big part of the scene,” yet it was up to the individual students to make it part of their own scene as few rules and expectations were laid out at the beginning.

Passive and Active Interaction: Movement as Desirable

She describes the dog wandering around (movement and desirable) as, “if the windows got open and you could be part of the outside world.” She then contrasts the course which requires a great deal of concentration, with normal work which requires little concentration, and that the in a normal work situation she would probably pay more attention to the dog than she did during the course. In other words, for Coral, the required concentration, perceived volume of work and need to stay focused prevented her from interacting with her environment, including other people and the dogs. This also suggests that the training room is not a normal environment, and one that is seen as more difficult to operate in than the real world of normal work. There is also a suggested syllogism here that you cannot pay attention to the dog and concentrate at the same time.

Coral says that she would probably be quite interested in the dog was well within her line of vision, likening it to a desk toy at a conference, stating that, “looking at the doing that and listening to other things coming in would probably be more complementary.” This suggests a use of dogs as visual stimulus for cognition in a similar way to a person doodling during a lecture.

She describes the physical layout of the room as a, “challenging set up,” that was not conducive to the dog wandering freely around. which she sees as a more positive aspect than having a dog lying in a corner that you can’t see, which she sees as pointless for her. Here she may be expressing a preference for active interaction with the dog (movement as pleasurable or desirable), rather than passive interaction through observation, and the mere presence of having little if any real value. So there is the contradiction in the movement as desirable (dog wandering around), but

conversely the responsibility of keeping him out of certain places was problematic and an unwelcome distraction.

Student Responsibility for Dog's Behaviour

She mentions that, “responsibility part of it [having a dog in the room] was tricky,” implying that as a student, she had assumed a level of responsibility for the well-being of the dog, and to, “keep the dog out,” of potentially unsafe areas. Though if assuming responsibility for the dog was tricky, we are no wiser as to what the trick was, implying that it was difficult or problematic. I think this is all interesting because at the beginning of the course I clearly defined the role of the handler, which was to look out for the welfare of the dog, and during the course where the handler was visible at all times. Furthermore, it was this added responsibility that was not only problematic and redundant, it was also a distraction for Coral. This begs the question as to why then would you assume responsibility for the dog? Perhaps one explanation is that Coral wanted to assume that responsibility, though the key driver or motivator here is unclear. How is keeping the dog aware of confined spaces different to keeping him within the confines of the room, as expressed by Alicia, and where people were up and down, in and out getting printing without closing the door, or from carrying hot water and coffee, sharp objects and so on that would lead me to believe that it was not the dog whom Coral was concerned about, but rather the equipment.

Physical Layout

Coral spends believes that the physical set up could be improved by including a teaching space between the desks so that the teacher could interact directly with them, and where the dog would be visible. She also describes the

isolating influence of the laptops saying, “it’s really putting people into like a little universe a little corral in the library.”

Power & Control

Coral expressed her disappointment at the quality of the course that she thought would be innovative, and criticised the teaching style and delivery, questioning it’s validity against government standards. It was at this point, through fear, that Coral asked for the interview to be suspended as she expressed a concern that it would get back, and she, “didn’t want any feedback.” She says that she went out on a limb, and took a risk in coming to this particular course, rather than with her employer who also provides the training, as she believed it would be innovative and wanted to learn through experience, how such a volume of content could be delivered within the duration of the course.

All this too reflects the underlying power structures operating in the environment at the time. Coral felt powerless against the teachers to say, “slow down,” to create some “slack off time,” proffering instead to interact with the teacher through conflict which ironically, further disempowered and isolated her, since other students saw this as inappropriate and rude behaviour towards the teacher. Whilst not disagreeing with Coral’s point of view, students did perceive the way she interacted as a negative thing. It also emphasises Coral’s powerlessness to influence her environment in not making the dog, “part of the scene,” for her. This confounds her self-ascribed positive disposition towards dogs, “I like dogs, so why wouldn’t I say that [it’s very pleasant having the dog around]?”

Personal Outlook

Coral’s overall disposition was negative, illustrated through her lexicon and negative framing: problematic, cannot be there, pointless, distracted, unwelcome,

tricky, her description of the workload, course structure and room layout, that was also well-illustrated through her fear of retribution during the discussion.

Is there a link between Coral and Reggie that I have not looked at yet, something to do with negative framing and outlook, that is evidenced in their lack of interaction with the dog and further through behaviour and vocalisations, that socially separated Coral and Reggie from the rest of the group? Interesting to note that these two people did not socialise during the breaks (morning tea, afternoon tea and lunch) either, but then again neither did Morgan, Leigh, Mary and a few others.

APPENDIX H: SAMPLE OBSERVATION ANALYSIS

Observation	Code
Main plot	
<p>The class began a few minutes before 9.00 am and Tanya explained the assessment criteria for the presentation sessions to those students who were present, and a couple of students arrived a few minutes later. As Tanya wrote on the whiteboard, Buddy and Amanda arrived, were introduced to the group, and took a seat on the sofa at the back of the room.</p>	Dog introduction.
<p>After fifteen minutes, Tanya left, and Sam asked who would be presenting first. Some students got a cup of coffee and spoke with their neighbours. Leigh then got out of her chair and set up for her presentation, and delivered her sample training session on collating and folding brochures. Sam facilitated a brief feedback session with students on Leigh's presentation, as students completed an evaluation sheet. Sharon then set up and delivered a PowerPoint supported presentation on communication followed by an exercise on Chinese whispers. After Sharon's lesson, students completed a feedback sheet and several</p>	<p>Student role reversal. Distraction. Getting Drinks. Micro-conversations.</p>

minutes later Sam adjourned the class for the morning break.

Dog sub-plot

When Buddy was introduced to the students, several	Dog appeal.
students sighed and said, “Ooooh,” and commented	Talking about dog.
how cute they thought he was. Danni asked if he was a	Talking to dog.
particular breed and Amanda said that he was a	Watching.
Cavoodle. When Andy arrived several minutes later he	Passive dog.
asked loudly, “Who’s this little one?” Amanda and	
Buddy, who was off-lead, then walked across to the	
sofa, and Dan, Sharon and Mark turned and leaned	
over the back of their chairs to watch him. Buddy then	
sat on the sofa with Amanda for the duration of the	
lesson.	
Shortly after the start of the lesson when Mark walked	Watching.
back to his chair after speaking with Mary, he paused	Patting.
and looked down at Buddy before sitting down. As	
Leigh set up for her presentation, Sam walked over to	
the couch and when she leaned down to retrieve	
something from her bag she briefly patted Buddy. On	
several occasions during the Leigh’s presentation,	
Sharon glanced around at Buddy.	
When Mark returned to his desk after getting some	Talking to.
paper for Leigh’s activity, he looked at Buddy on the	Student desire for activity.
couch and asked, “Are you a happy puppy?” On one	

occasion during Leigh's activity when Wynnie folded her brochures, she said that it was fun because she had something to do, and that she wanted to play with Buddy.

When Sharon briefly stood up during the feedback of Leigh's presentation, something dropped onto the floor and Sam turned and said, "Buddy, fetch," and Sharon and Dan turned to look at Buddy. Several minutes later when Borat got up to get a drink, Buddy walked over to him and sniffed his feet before walking back and jumping up again on the couch. Shortly after, Alma and Buddy briefly left the room and when they returned, sat back down on the couch.

When Sam returned after leaving the room briefly as Sharon set up for her presentation, she walked over to the sofa and said that her, "bubby got his needles yesterday," and patted Buddy briefly.

During Sharon's presentation, a picture of a small terrier-type dog with its mouth open wide was displayed on the opening slide, to which a few students laughed. Sharon then made a comment about the hazards that people needed to be careful of that included cords and, "our new dog," to which a few people laughed. She continued her presentation, and said that the dog was her assistant at work, and that he

Commanding dog.

Watching.

Drinking.

Sniffing at.

Talking to.

Patting.

Picture of dog.

Safety of dog.

Dog as representation.

was alerting her that an email had just come in.

Wynn timer and Danni laughed, a few people smiled, and

Danni briefly put her face in her hands.

When Andrea returned after leaving the room during

Sharon's activity, she turned around and looked at

Buddy and said, "it's hard work up there." Buddy then

leaped off the sofa and dashed to Andrea who, smiling

broadly, said that she wanted a dog like Buddy. At the

end of Sharon's presentation, a picture of two small

terrier-type dogs looking up and outwards was

displayed on the last slide, next to which was written,

"Thank you for listening, and don't forget to fill out

the feedback sheet."

Student sub-plot

The group on Mark's side had spread out a little as

Coral and Reggie were no longer in attendance, and

Mary and Leigh had swapped seats and also spread out

as Wade was no longer present. Borat arrived five

minutes after the class started, and Andy arrived a few

minutes later.

During the lesson, students frequently spoke with their

neighbours, engaged in micro conversations,

frequently laughing, occasionally speaking across the

desks. Also during the lesson, many students got out

of their chair to either get a drink from the coffee

Talking to.

Coaxing commanding.

Smiling.

Appeal.

Picture of dog.

Absent

Move seats.

Micro-conversations.

Drinks.

Leaving room.

Printing.

Confined space.

table, printing from the front desk, or left the room for several minutes and occasionally carried sheets of paper when they returned, squared papers on their desk, and picked up folders and books that they put on the desk behind them. On two occasions during the lesson when Borat got up to make a cup of coffee, he also made one for Andy.

At the start of the lesson, when Sam asked who would be presenting, students spoke amongst their neighbours as Mark got up to get a drink, and spoke with Tanya and an unidentified female who had entered the room, Borat and Wynn timer got out of their chairs and walked across to the coffee table, and Leigh got out of her chair and walked to the front of the room where she set up for her presentation.

At the start of Leigh's lesson, she handed printed copies of her slides to Sharon, who passed them around the group. She then stood at the front of the room, occasionally looking up at the screen and then at the group as she delivered her presentation. After several minutes, Leigh explained and demonstrated how to correctly fold a letter with a brochure. She then walked around the room answering questions of individual students. On one occasion she asked Sam how to print handouts from her PowerPoint display.

Drinking.

Intruder.

Difficulty using other artifacts.

During Leigh's presentation several students go out of their chairs to get the papers they needed for the exercise that had been placed on the table behind Wynnie. On one occasion Andy turned his cap around the wrong way leaned on the desk with his cheek in his hand, Brad leaned back, and Morgan briefly turned and looked around the room to her left at no one in particular and smiled briefly. On another occasion Borat leaned back with his arms crossed in front of him and yawned as Leigh handed a set of papers to Sharon who passed them around the group. As students completed the exercise during the lesson, Wynnie asked no one in particular, where Brighton was, and if it was in Brisbane.

Student disengagement.

When Leigh finished her lesson, students applauded, and began writing down on the paper in front of them. Leigh then removed her USB stick that contained her presentation, and thanked the group who applauded quietly again. She then spoke briefly to Sam before returning to her desk at the back of the room. As Sam explained the evaluation document after Leigh's presentation, people typed into their computers and spoke quietly with each other, occasionally laughing. On one occasion Morgan pointed at Danni's screen, and laughed slightly as she whispered to her.

Distraction by computer.

Sharon then set up for her presentation, during which time Wynn timer, Danni and Morgan spoke about the printing problem. Danni screwed her face as she spoke about the reaction of the staff in the office to the flashing printer lights.

Difficulty using other artifacts: printer.

Sharon began her presentation by explaining to the students about communication in the workplace, using the PowerPoint display. She then introduced a *Chinese Whispers* activity and some students laughed. She handed a sheet of paper to Sam who said that the story was “huge.” As Sam read the story, students spoke with their neighbours. Andrea leaned back in her chair, stretched her arms behind her and yawned. Wynn timer and Danni spoke about the printer. After she finished reading the story, Sam then leaned over and whispered in Dan’s ear, and in turn, each student whispered the story to their neighbour. During this time, Andy spoke to Sam across the tables about what was required for his presentation, and Sam said that he should not be nervous or panicking, to which he affected a nervous shake. Several students got out of their chairs to make coffee, others continued micro conversations occasionally laughing, and some students left the room briefly. After several minutes, Andrea said that she “can’t wait to hear how it [the story] comes out.”

Student disengagement.

Drinking.

Student disengagement.

When students finished passing the whispered message, Sharon asked Andy what the message was. Andy said that he had not been listening and recited the distorted story, to which there was loud laughter around the group. Brad said that they had all been railroaded. Sharon continued her presentation by explaining the importance of listening at work, and after she had finished she asked people to fill out a form that she handed to Andy who in turn handed them to other students.

Students then filled out the sheets of paper, and continued talking with each other, occasionally laughing. On one occasion Andy said that he had been punched out for using quotes in the air that Alma used, and asked what it meant.

Teacher competence.

Teacher

At the start of the lesson, Sam asked the group who would be presenting today as she had left her notes at home. When Leigh went up to the front of the room Sam, walked over and sat in Leigh's chair for the duration of her lesson, and got up briefly before the start and walked over to the couch and retrieved something from her bag. On several occasions during Leigh's lesson, Sam briefly spoke to Mary and they both smiled and laughed. On one occasion Sam spoke

about BMW cars.

When Leigh finished her lesson, Sam got up and offered Leigh her seat back, walked across to Sharon.

Teacher encouragement.

Intruder.

As she stood next to Sharon, Sam leaned over and gently rubbed her back and said that she was, “alright.” When Leigh packed up from her presentation, and shortly after Nicole entered the room and spoke briefly with Sam. Sam explained that they were waiting for a delivery of paper.

After Leigh’s presentation, Sam stood at her desk, leaned over her computer and opened and scrolled through a document. She then spoke briefly with the group and occasionally looked over her shoulder at the screen behind her. She explained that the document was an evaluation sheet for Leigh’s presentation, and asked people how Leigh’s session was. On one occasion she commented that the assessment tasks could have been better explained if students were not all talking.

Teacher discipline.

She then asked Sharon to set up and present next. When she returned to the room after leaving briefly to ask Johannes about the image problem on the screen, she walked to the coffee machine, over to the couch where she retrieved something from her bag, and returned to the coffee table before sitting in Sharon’s

Difficulty using other artifact: projector.

Drinking.

seat for the duration of Sharon's presentation.

After Sharon completed her presentation and packed up, Sam spoke to the group about bad habits as a presenter, and said that it was a good idea to get videotaped to pick up bad habits. She then looked down at Sharon as told her to watch her "ums." After several minutes, Sam said that it was time for a break.

Environment

There were a number of intruders during the lesson. Intruders.

The first was an unidentified female who entered the room through the front sliding door towards the end of Tanya's presentation at the start of the lesson and spoke to Tanya as they made coffee. The second was Nicole who briefly entered the room and spoke briefly with Sam as Leigh packed up from her presentation.

The third intruder was Sally who entered the room shortly before Sharon set up for her presentation, walked over to the printer and then left. The fourth intruder was Johannes who entered the room shortly before Sharon started her presentation, and spoke to her. He returned a few minutes later and walked over to the coffee table where he made a cup of coffee before leaving again.

On one occasion at the start of Leigh's presentation, Mobile phone.
Mark's phone rang loudly and he answered it and

talked at his desk. During Leigh's lesson Dan put his phone to his ear as he answered a call and left the room. On another occasion as Leigh packed up from her presentation, Dan leaned over towards Mark pointed to the camera in his phone, and Mark with his PDA in his hand, got up and left the room for ten minutes. Andrea then leaned back and scrolled through her phone, and occasionally put it to her ear, and Dan his phone next to his PDA on the desk in front of him.

There were a number of attempts at humour during the lesson. The first attempt was made by Leigh during her presentation, when she mentioned *Bart Simpson*, to which students laughed. The second attempt was made by Sam at the end of Leigh's feedback session when she commented that Leigh was the best so far. The third attempt at humour was made by Andy when he recited the distorted story during Sharon's lesson, to which there was loud laughter around the group, and Brad said that they had all been railroaded.

When Sharon set up for her presentation, she asked Sam why the projected image was not displaying correctly, and Sam said that she would ask Johannes to look at it and she briefly left the room. Several minutes later, after Johannes left the room, Dan got up and adjusted the teacher's laptop screen. Shortly after,

Use of humour.

Difficulty using other artifacts: projector.

as Sharon continued her presentation, Sam explained that Sharon must move the mouse slowly to align the screen image correctly.

APPENDIX I: TEMPORAL MAPS OF OBSERVATIONAL DATA

Day 1, Tuesday, 6 February, 2007

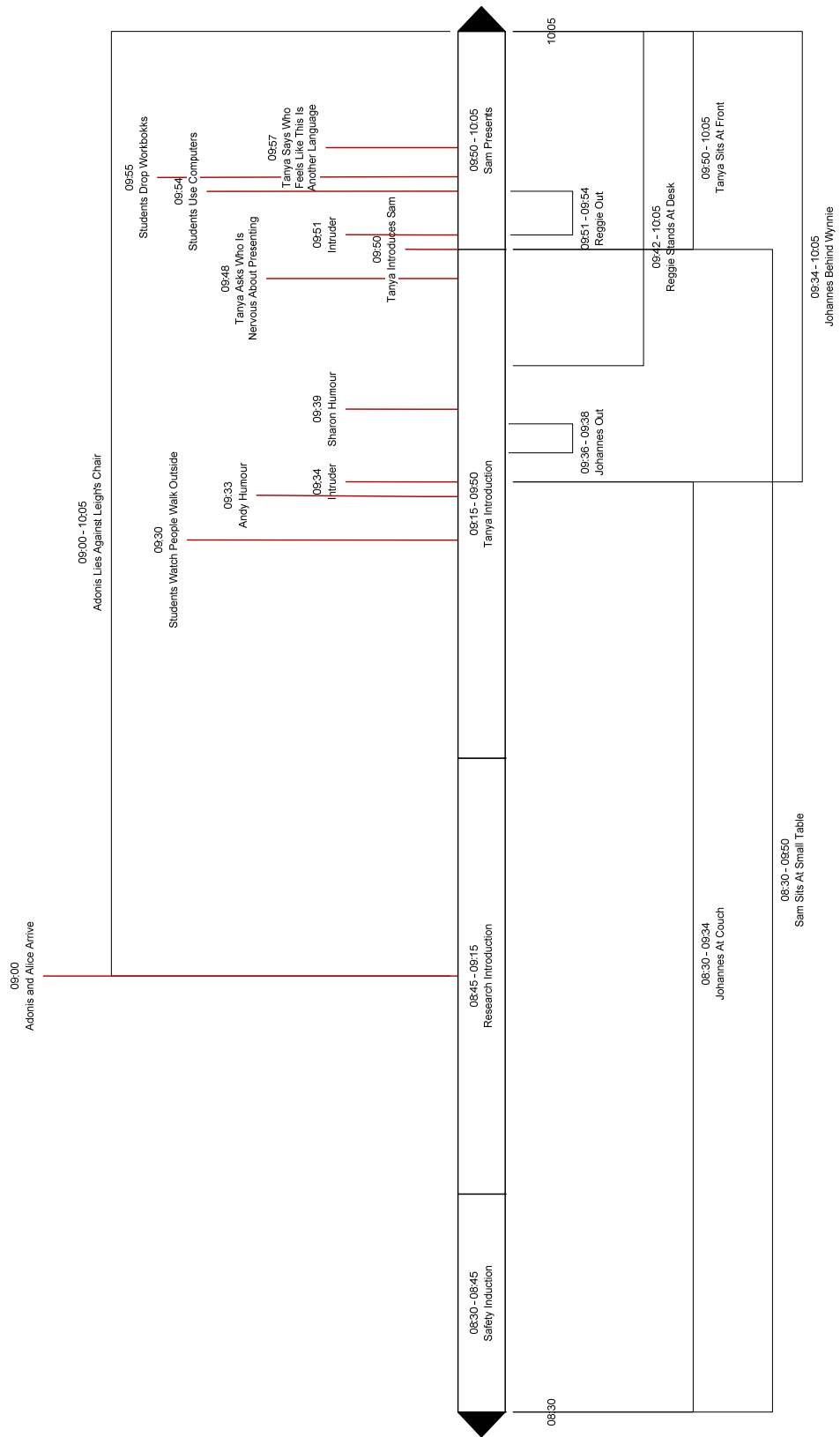

Figure II. Temporal map for teaching period 1.1.

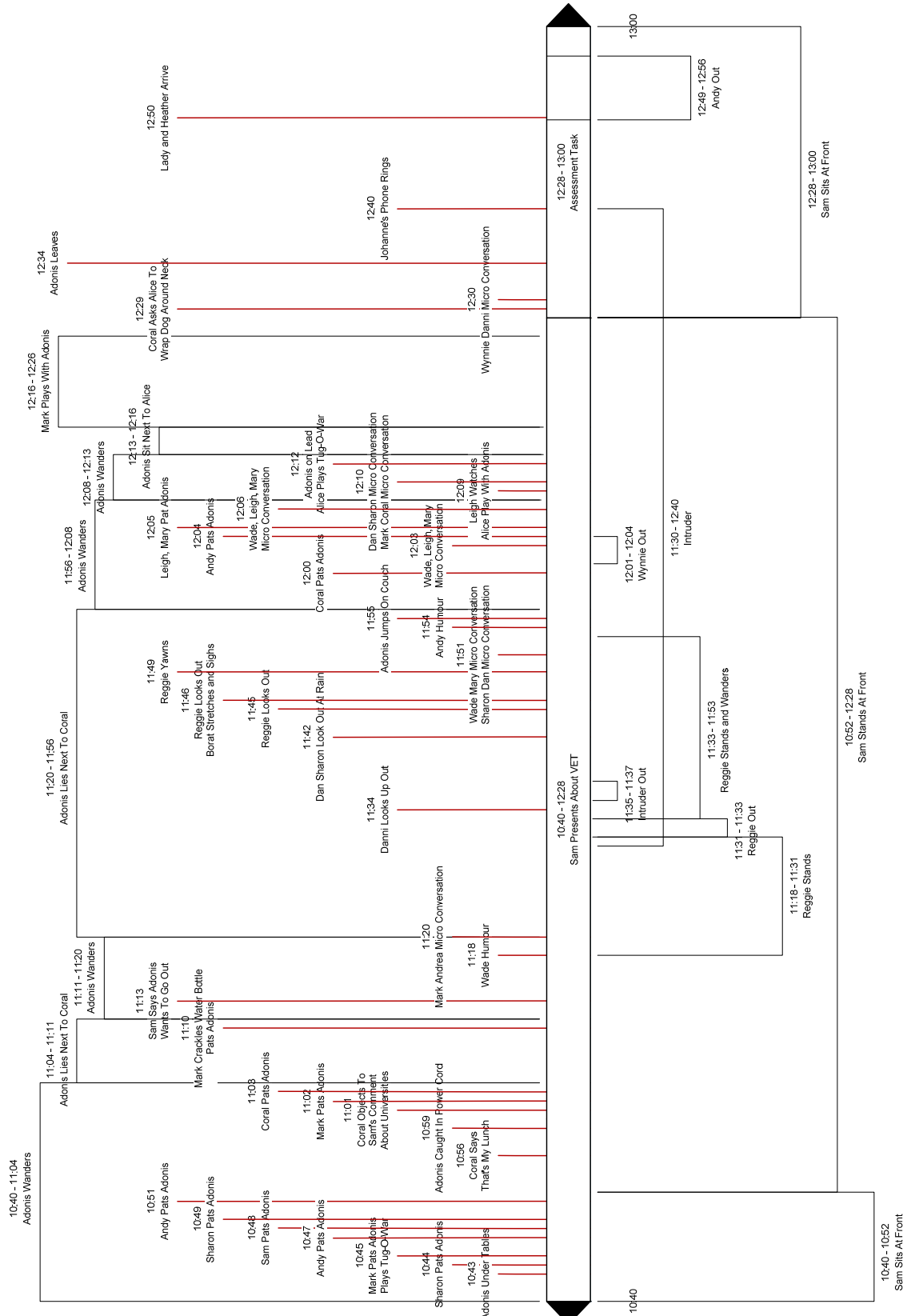

Figure 12. Temporal map for teaching period 1.2.

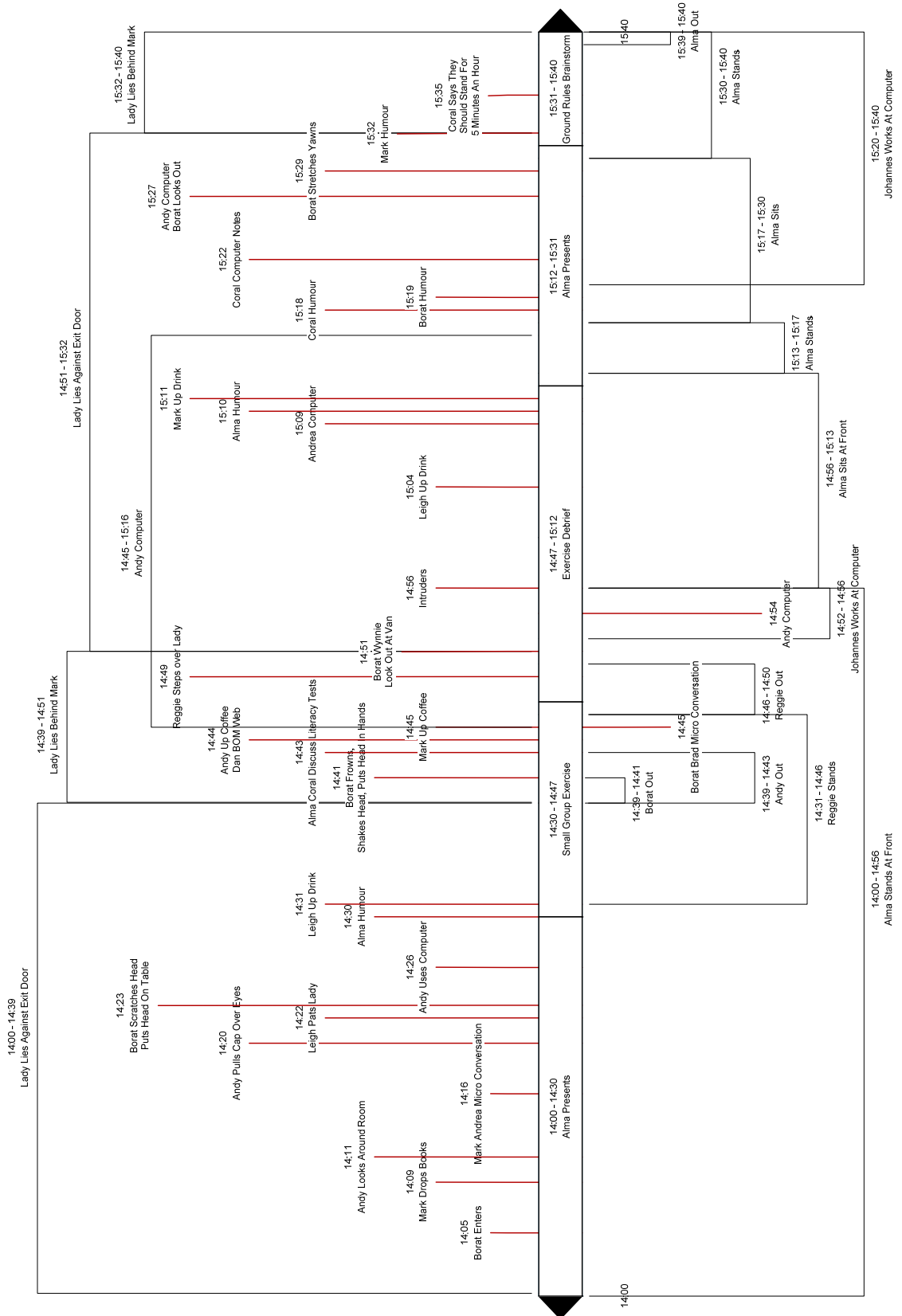

Figure 13. Temporal map for teaching period 1.3.

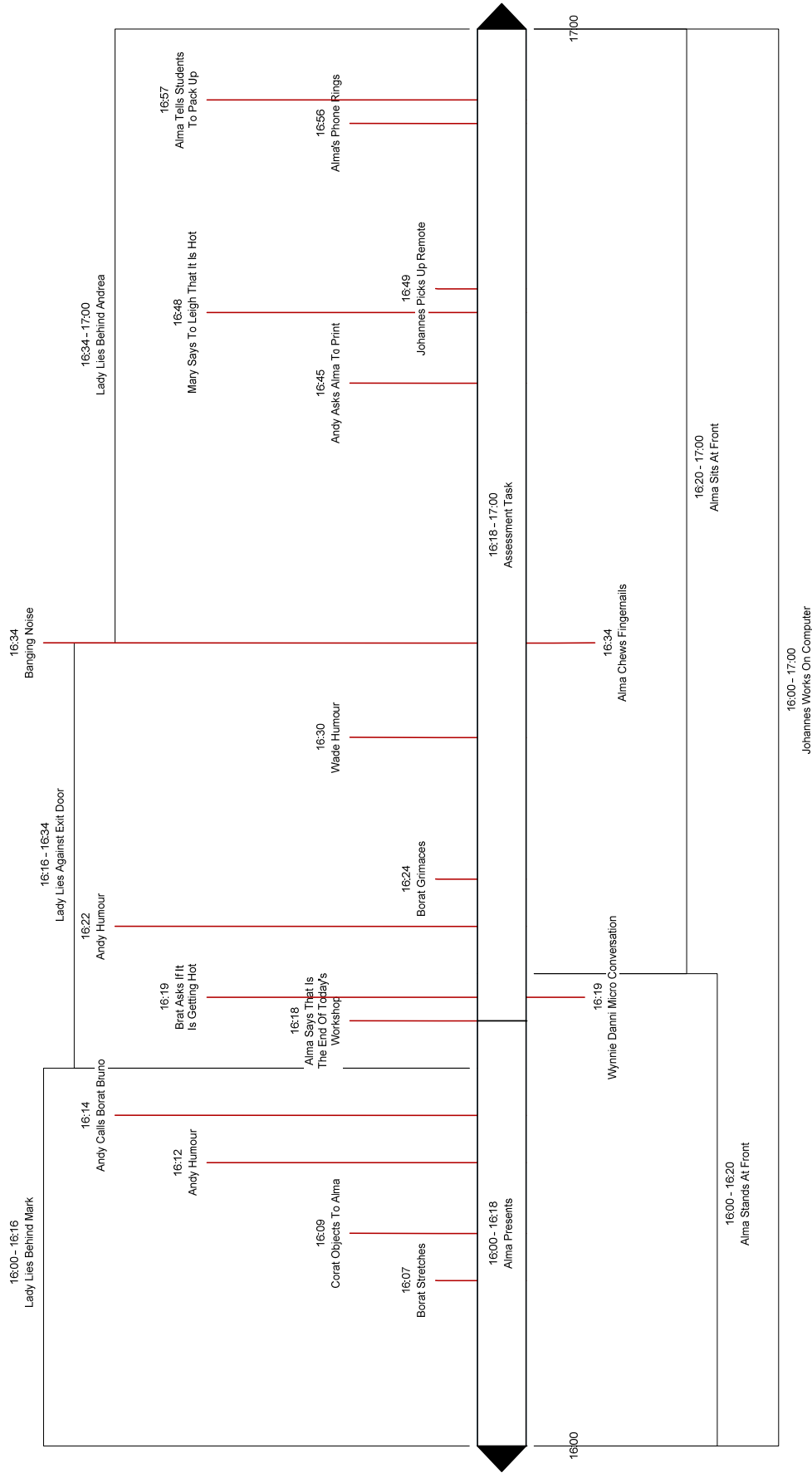

Figure 14. Temporal map for teaching period 1.4.

Day 2, Wednesday, 7 February, 2007

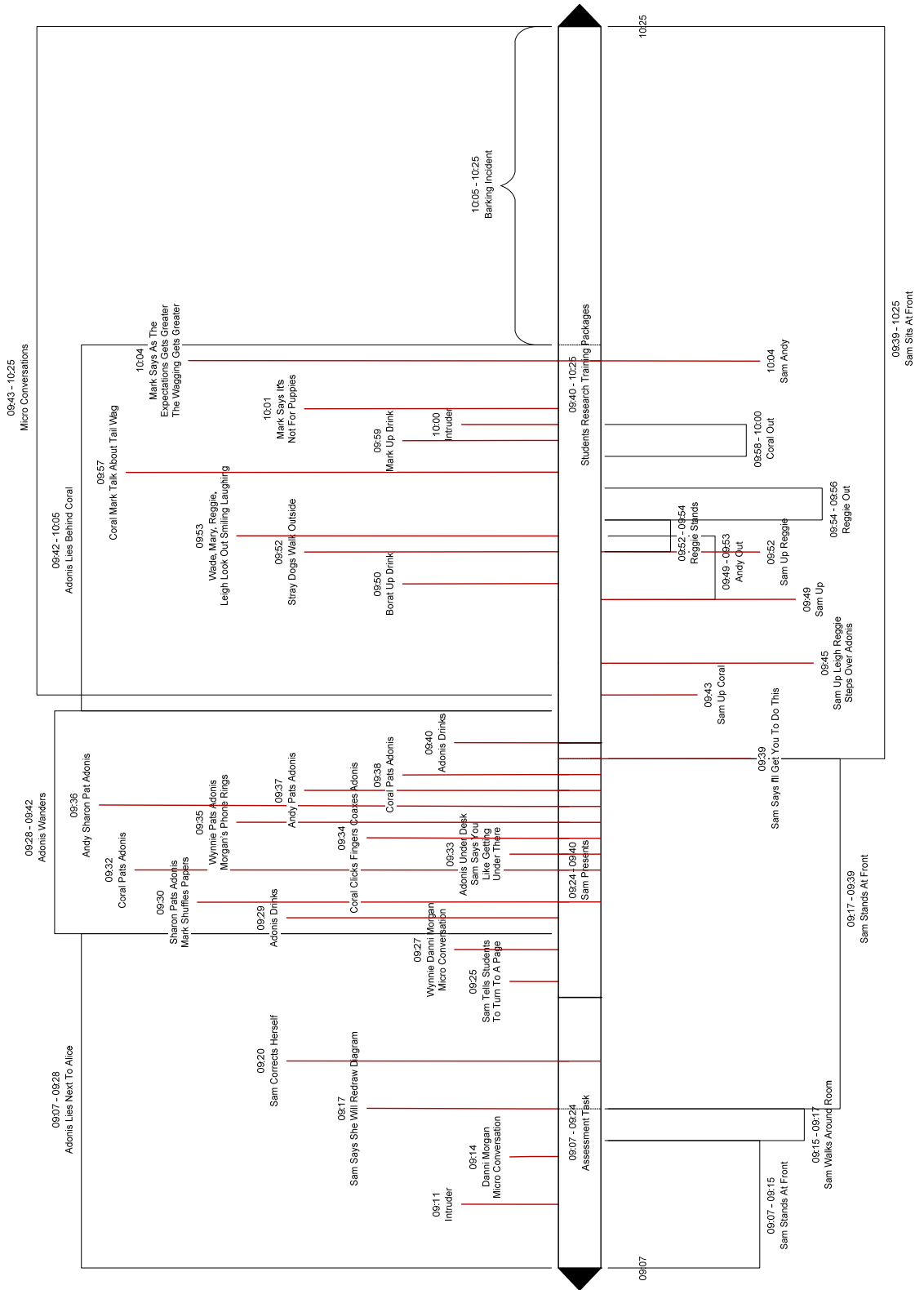

Figure 15. Temporal map for teaching period 2.1.

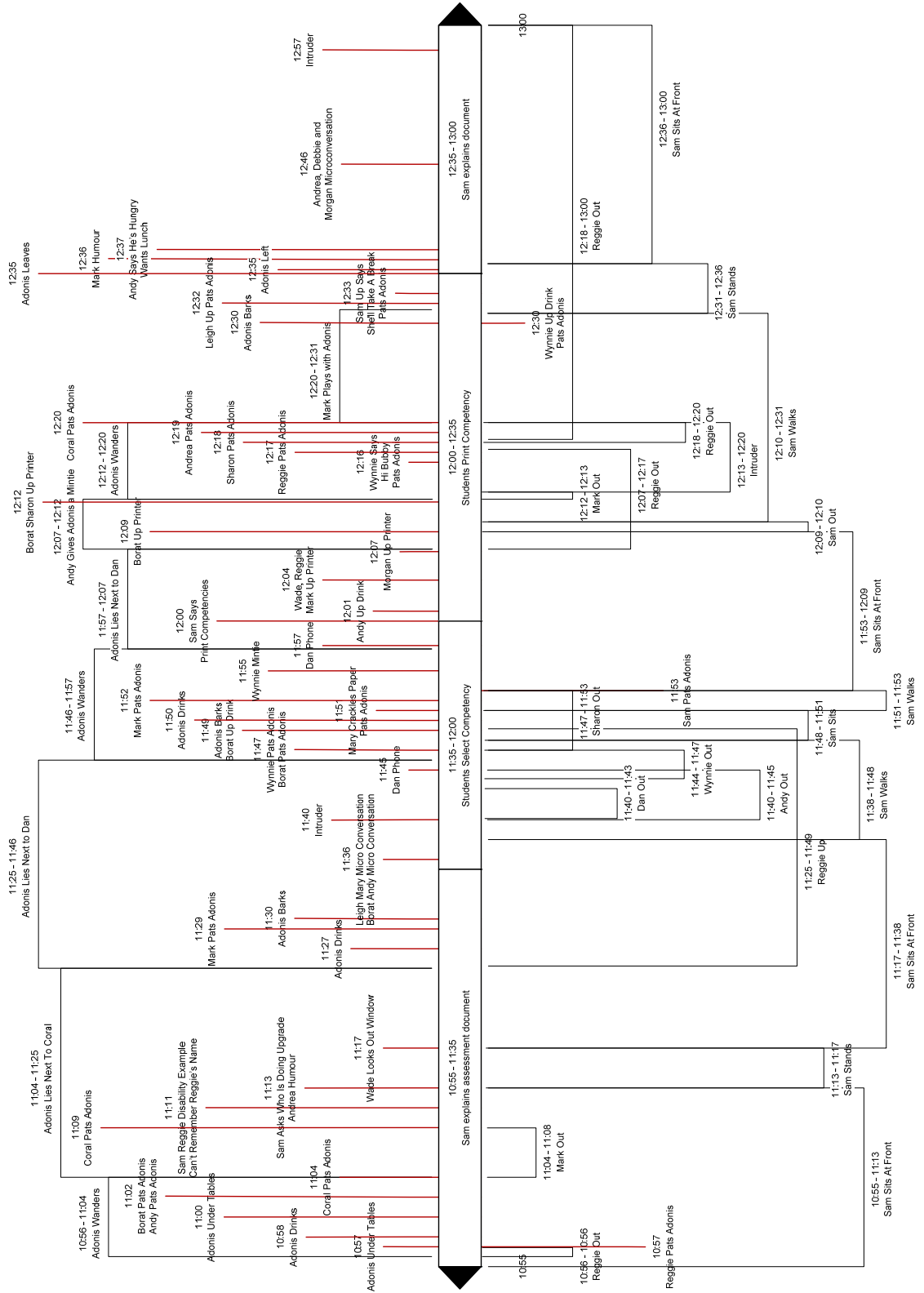

Figure 16. Temporal map for teaching period 2.2.

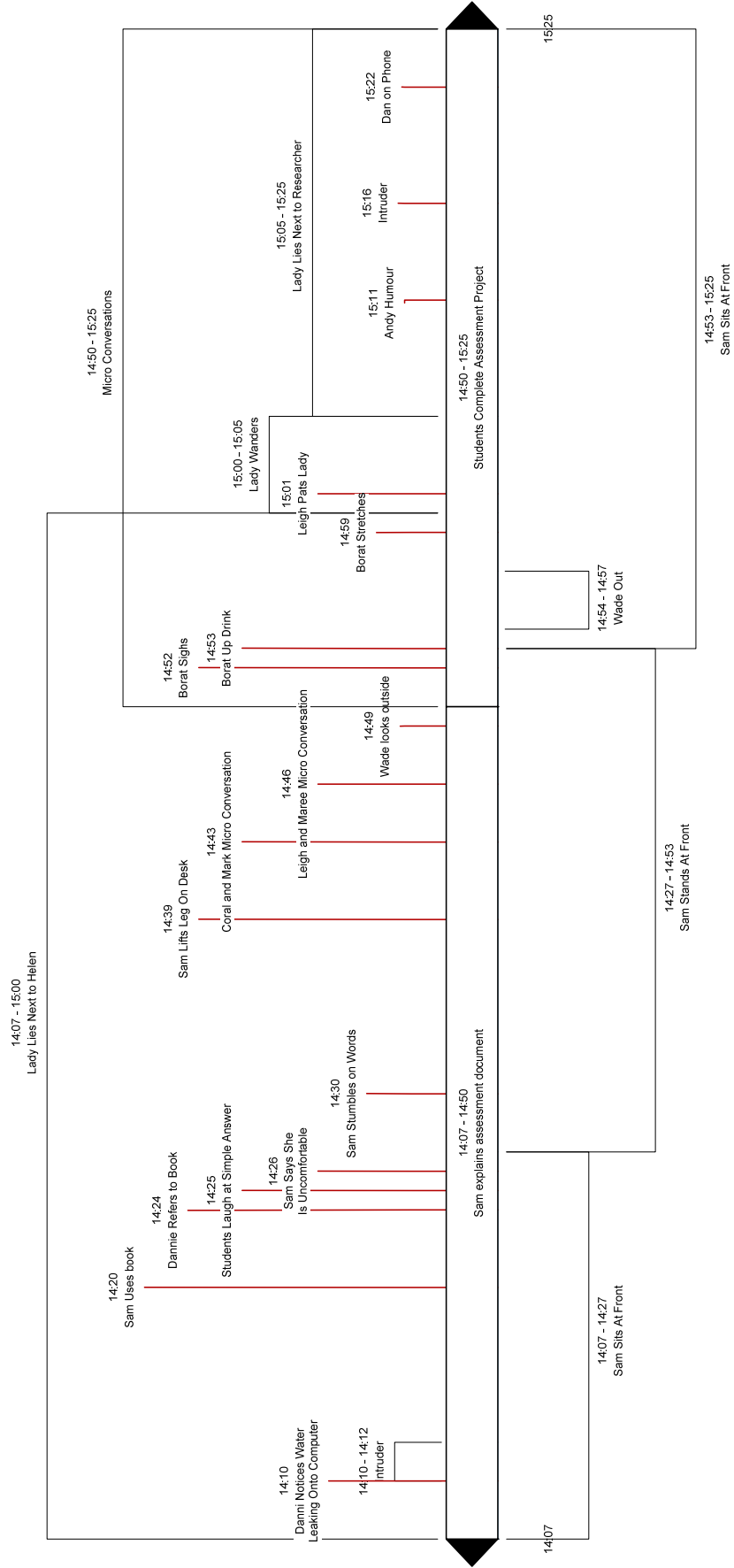

Figure 17. Temporal map for teaching period 2.3.

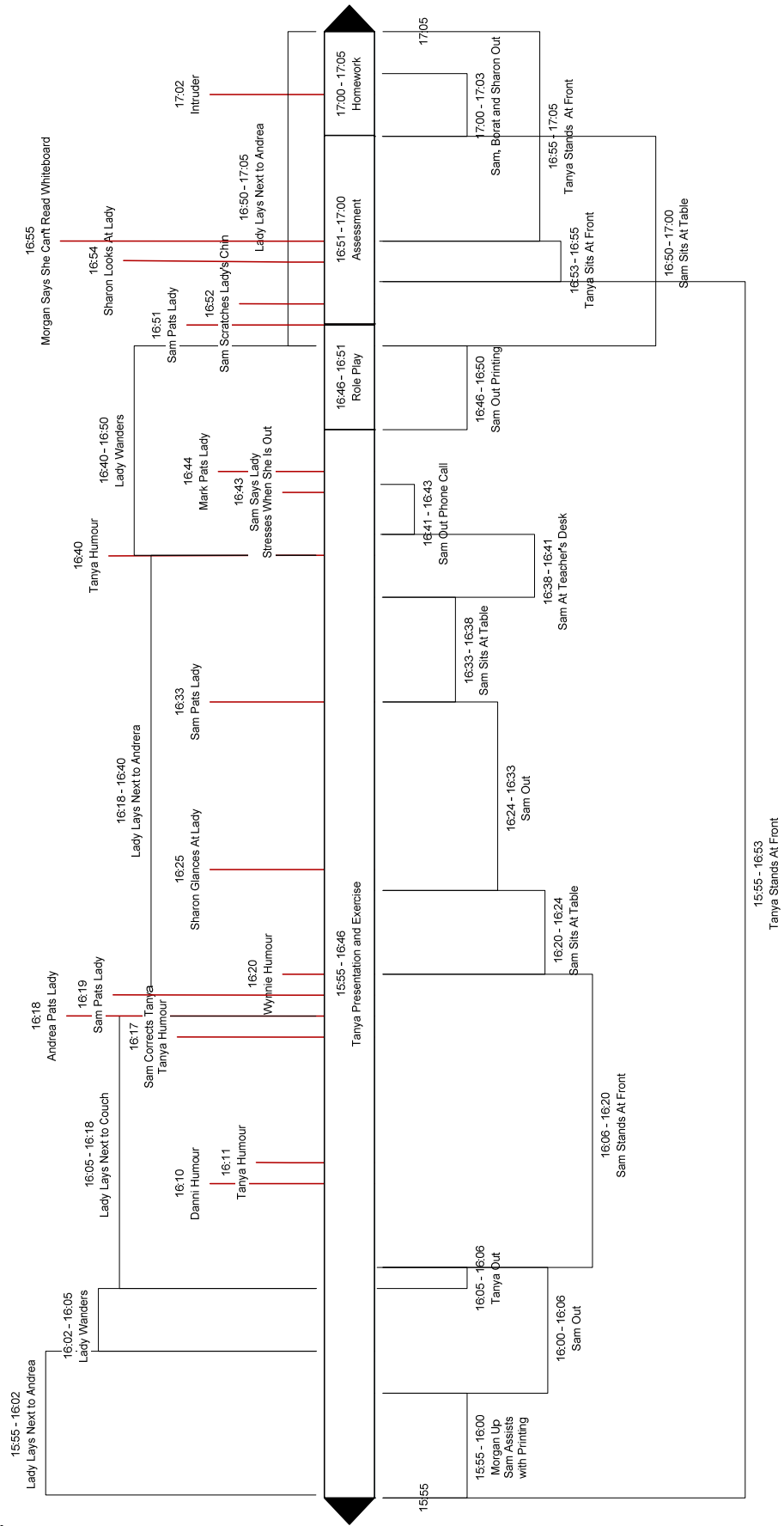

Figure 18. Temporal map for teaching period 2.4.

Day 3, Thursday, 8 February, 2007

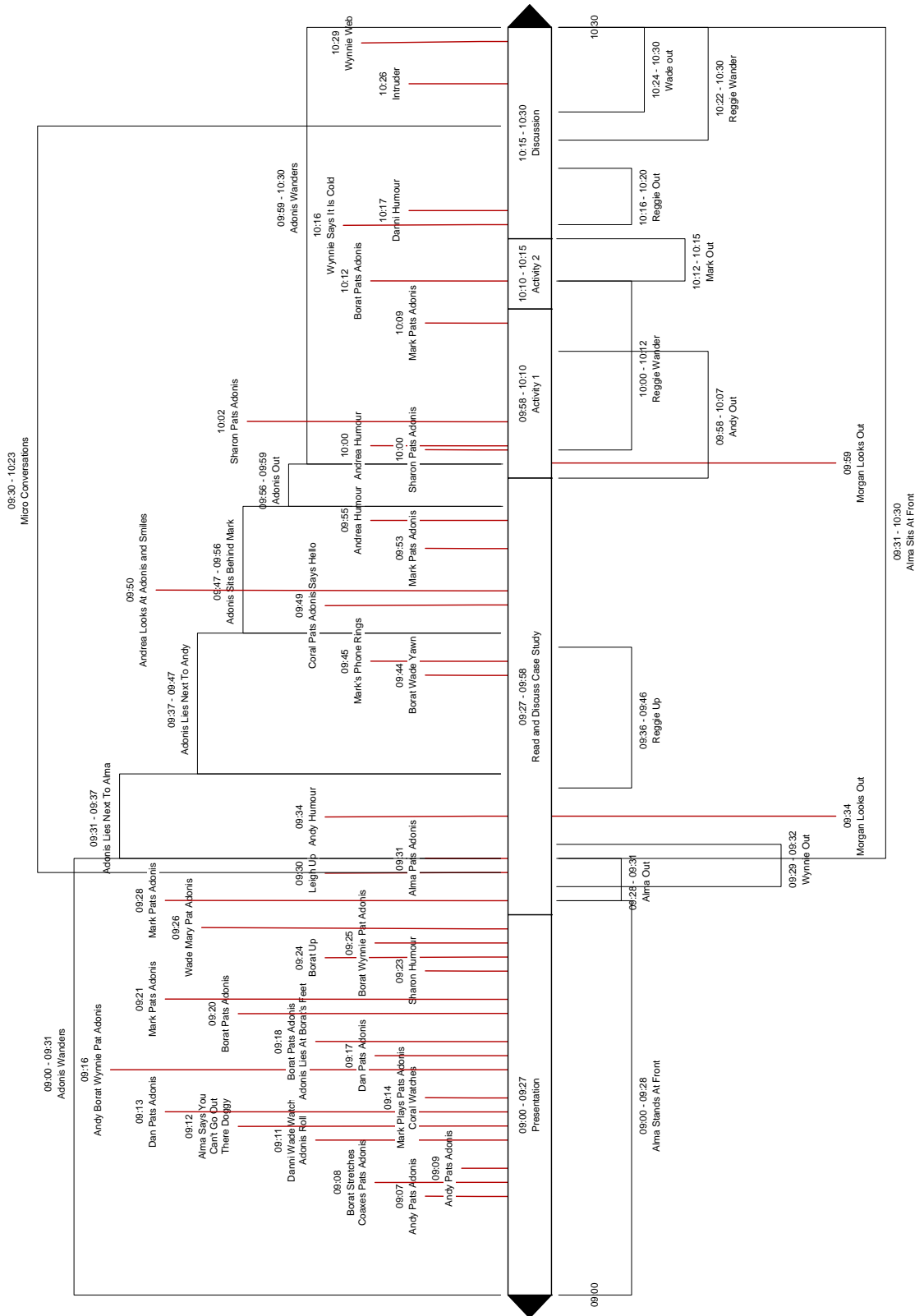

Figure 19. Temporal map for teaching period 3.1.

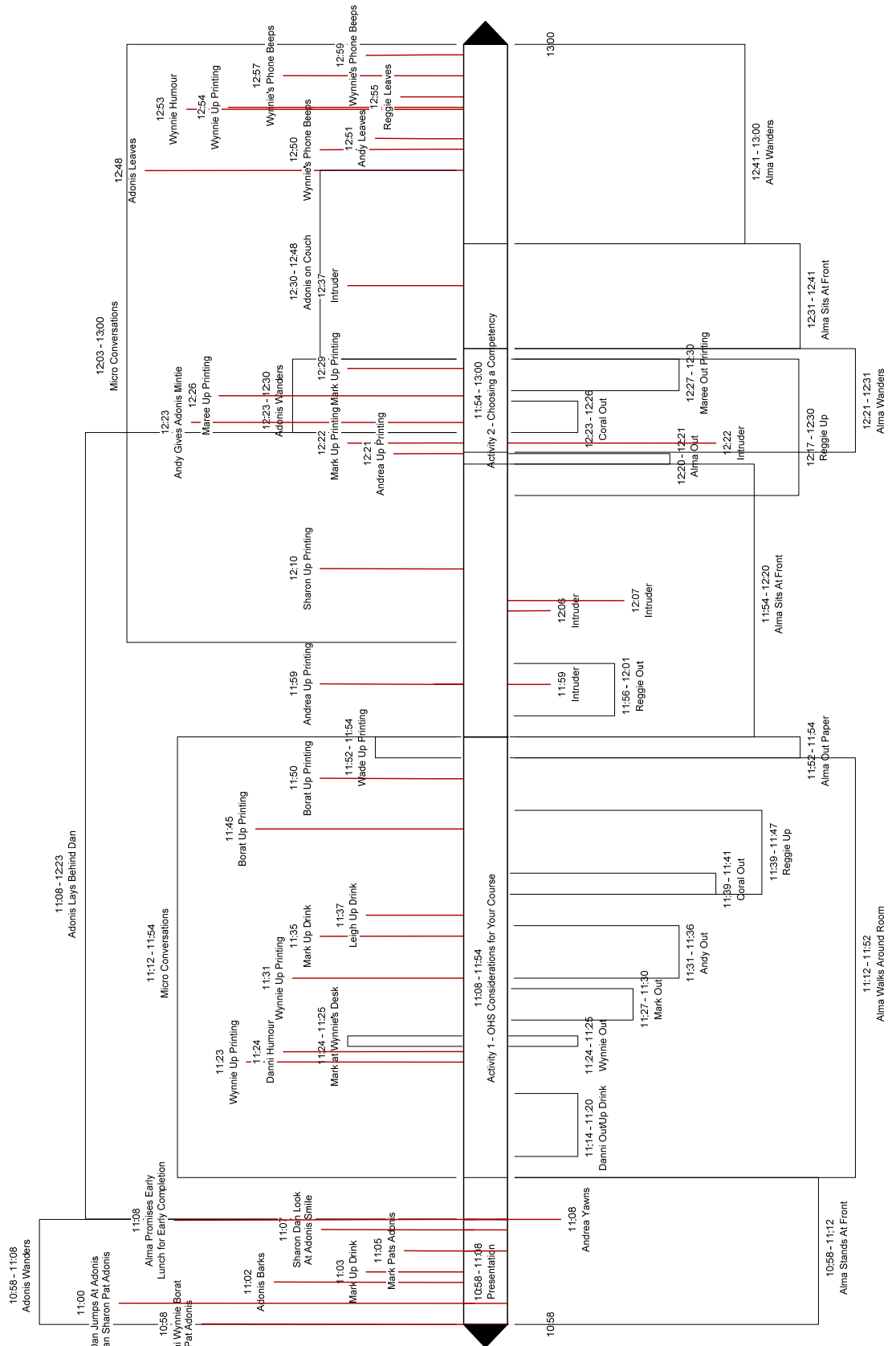

Figure 110. Temporal map for teaching period 3.2.

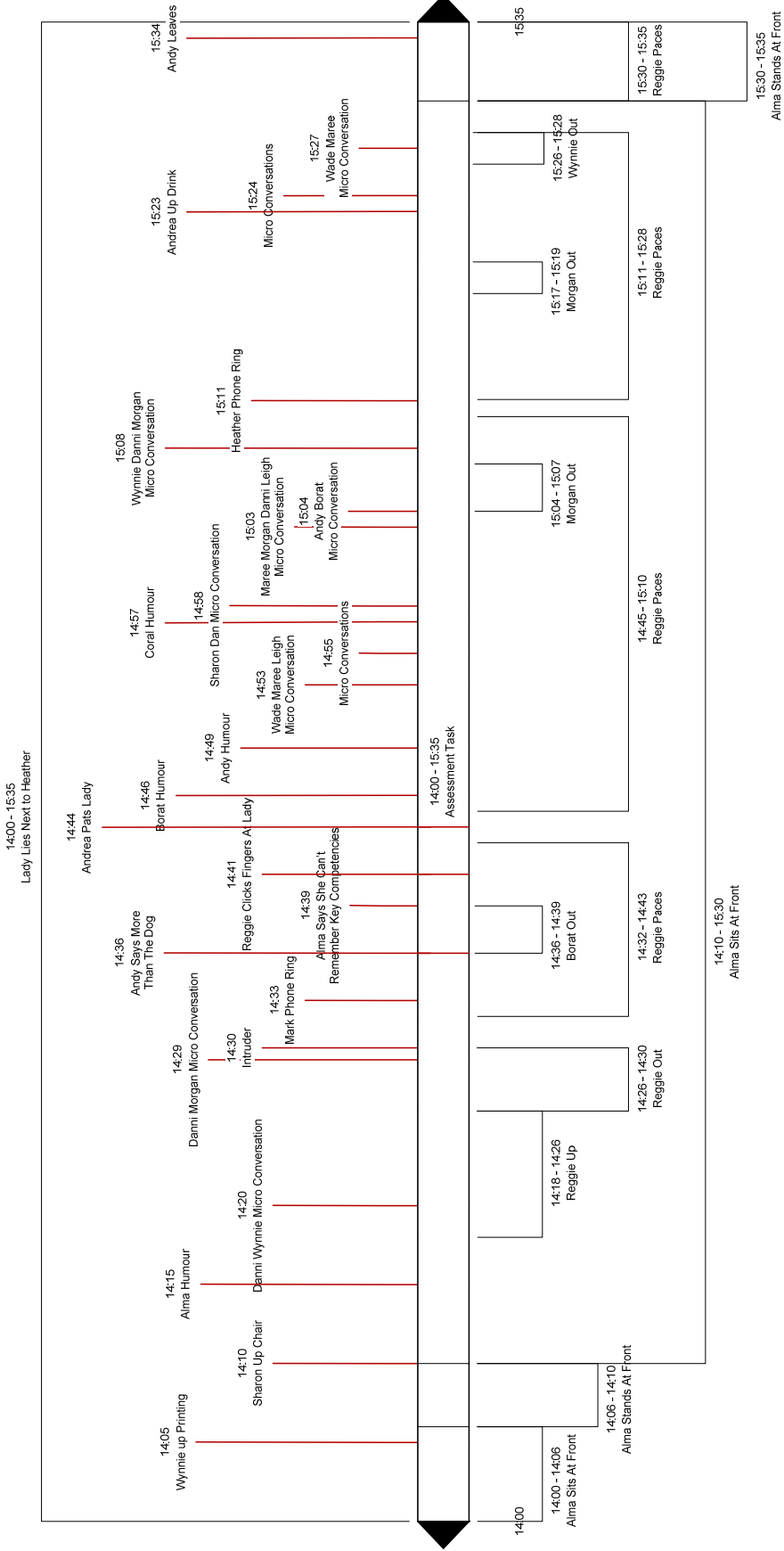

Figure III. Temporal map for teaching period 3.3.

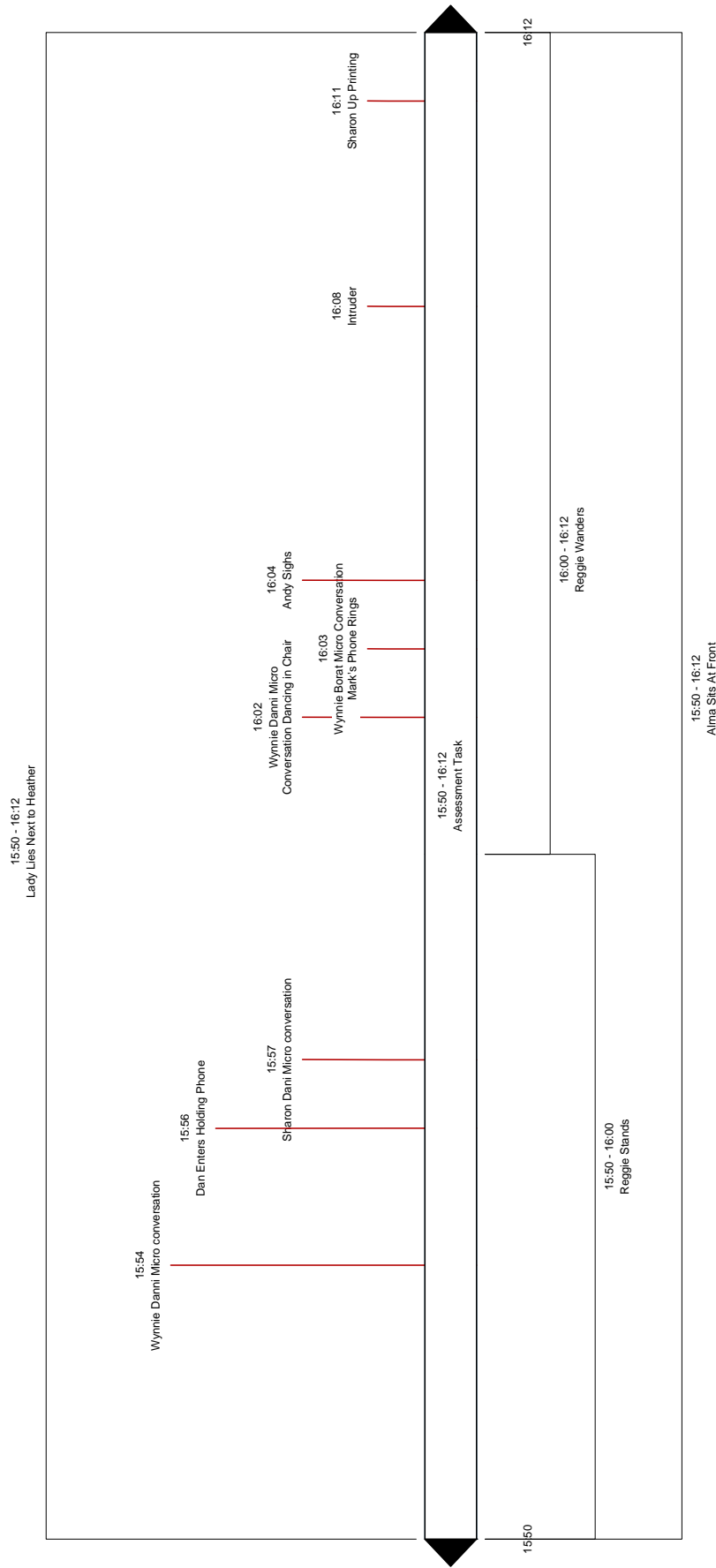

Figure II2. Temporal map for teaching period 3.4.

Day 4, Friday, 9 February, 2007

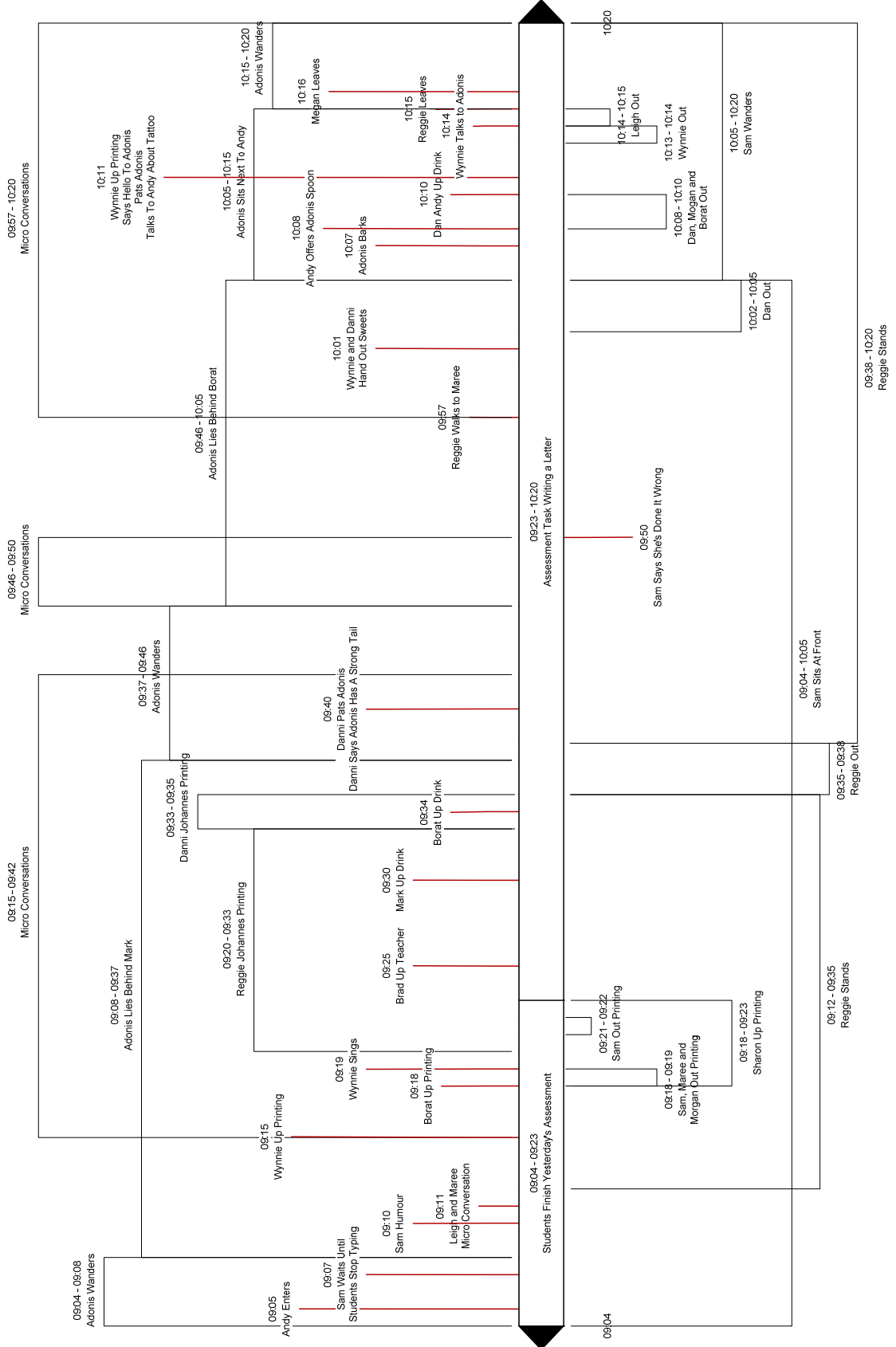

Figure 113. Temporal map for teaching period 4.1.

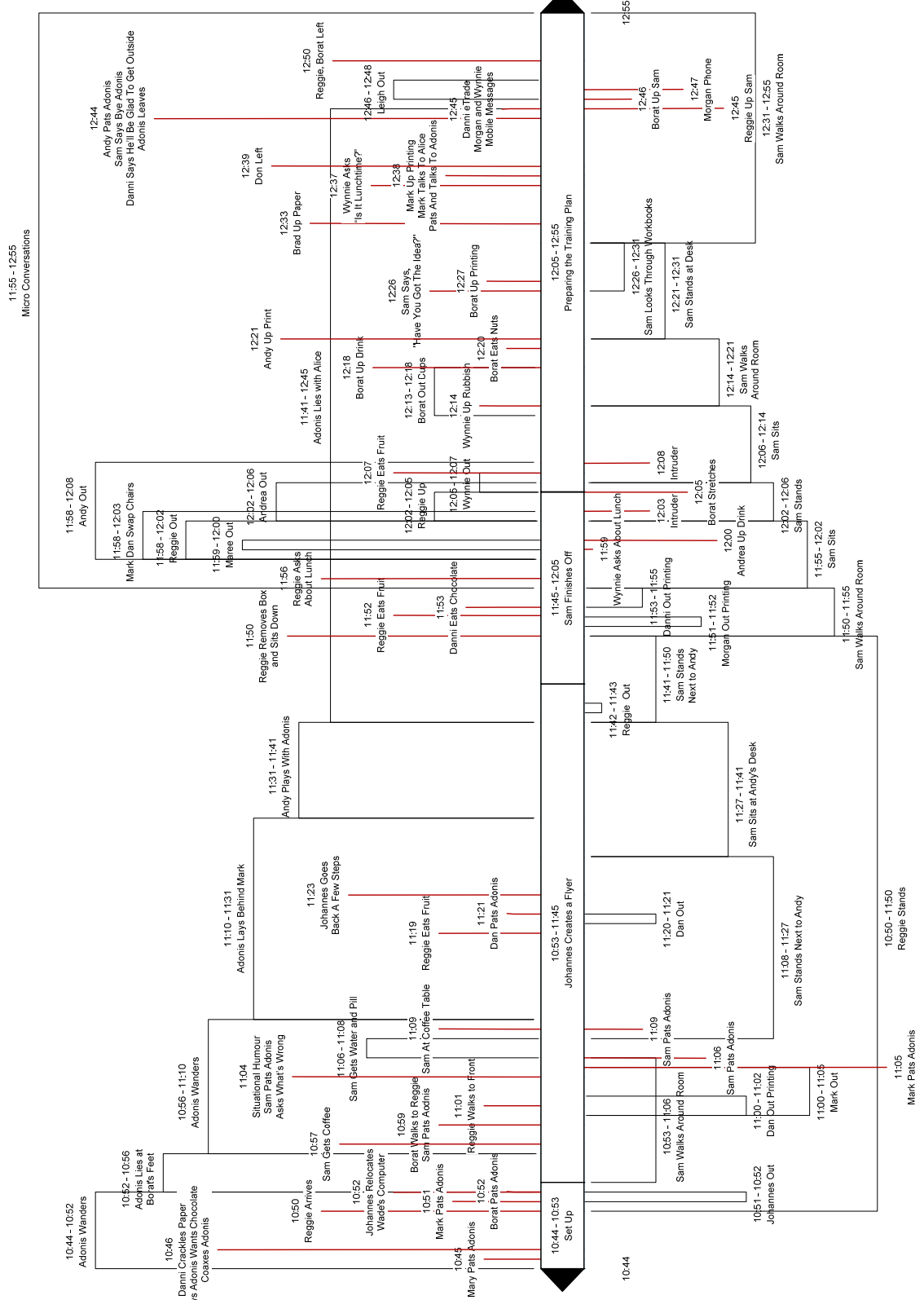

Figure 114. Temporal map for teaching period 4.2.

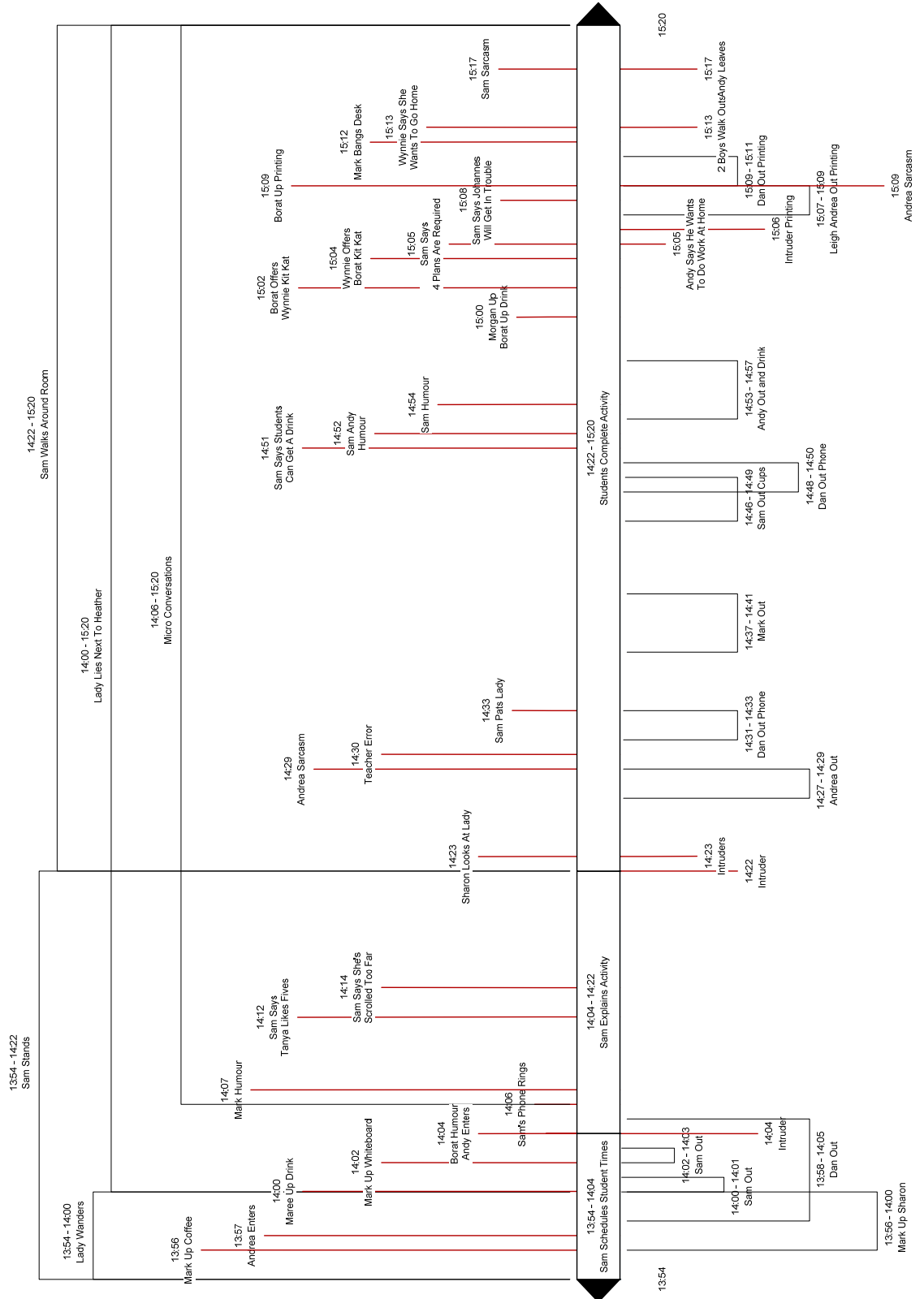

Figure I15. Temporal map for teaching period 4.3.

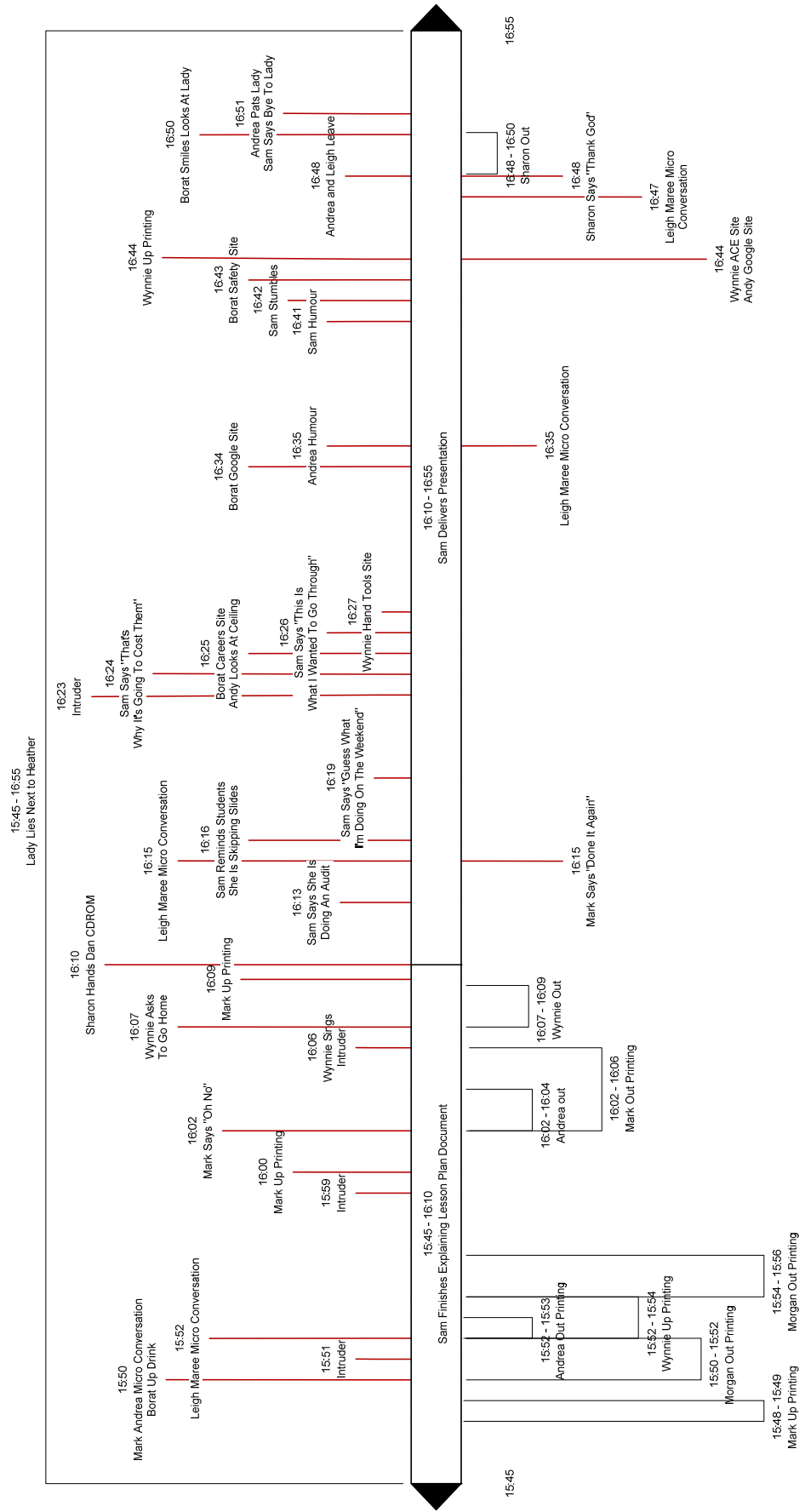

Figure 116. Temporal map for teaching period 4.4.

Day 5, Tuesday, 13 February, 2007

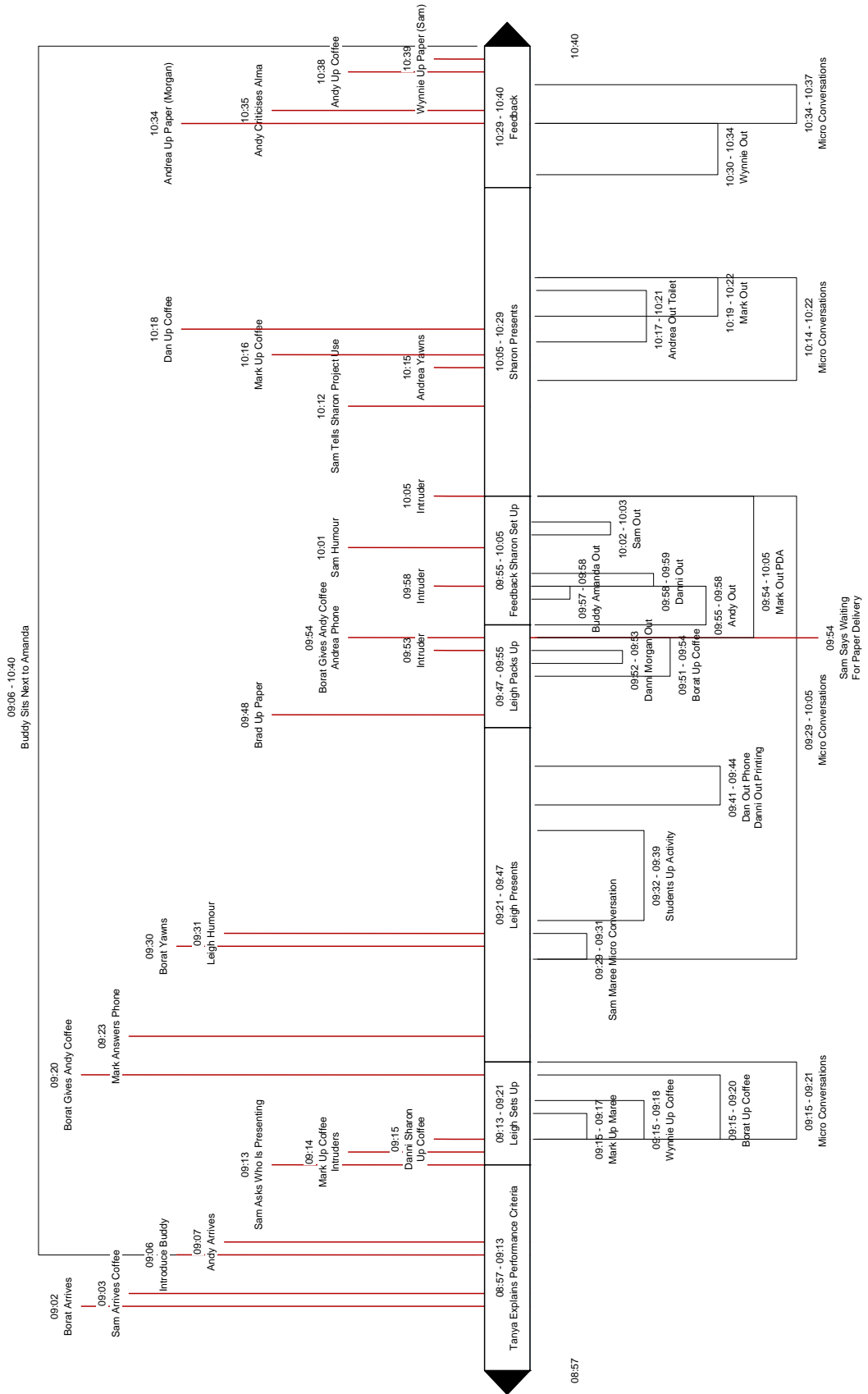

Figure II7. Temporal map for teaching period 5.1.

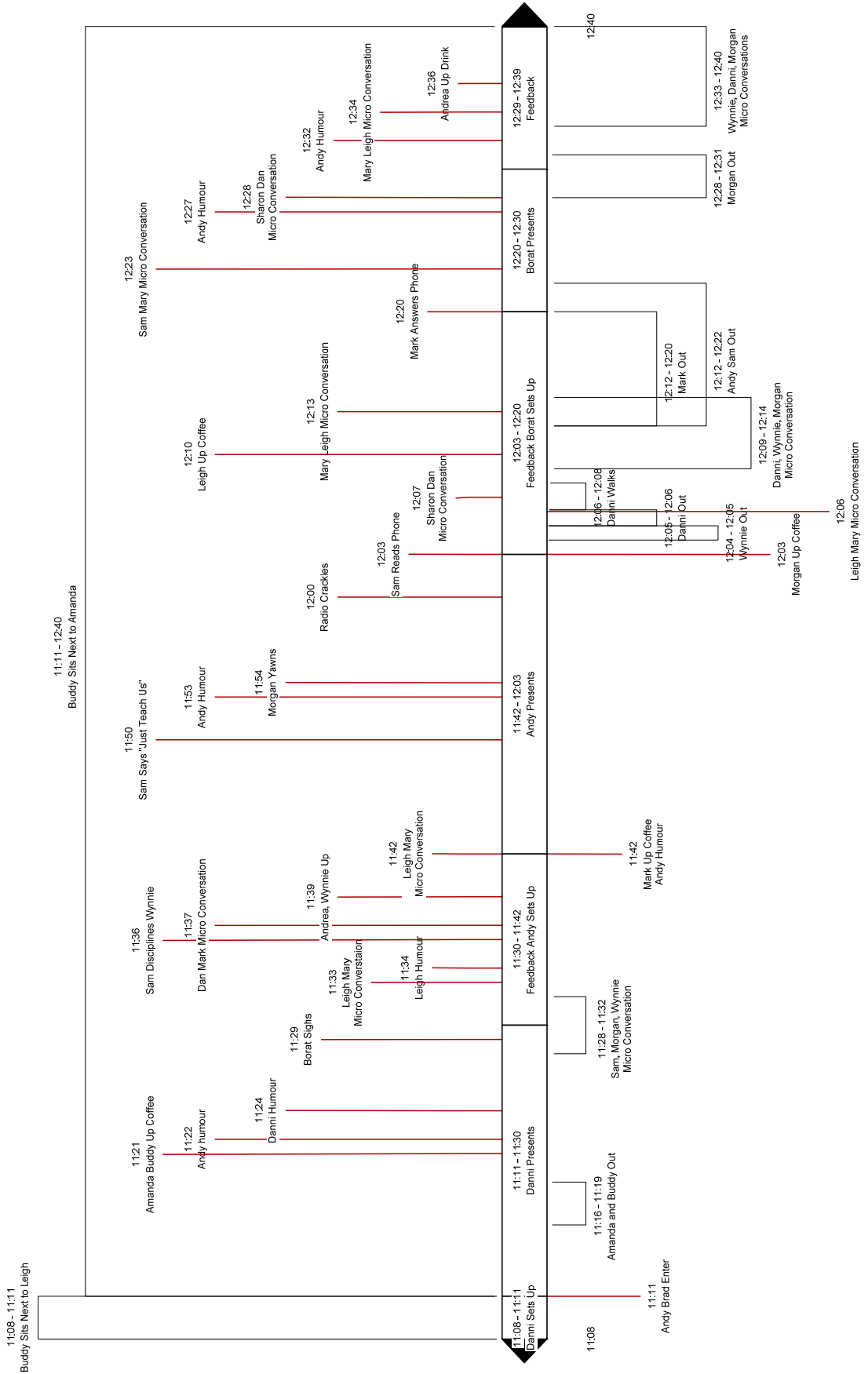

Figure II8. Temporal map for teaching period 5.2.

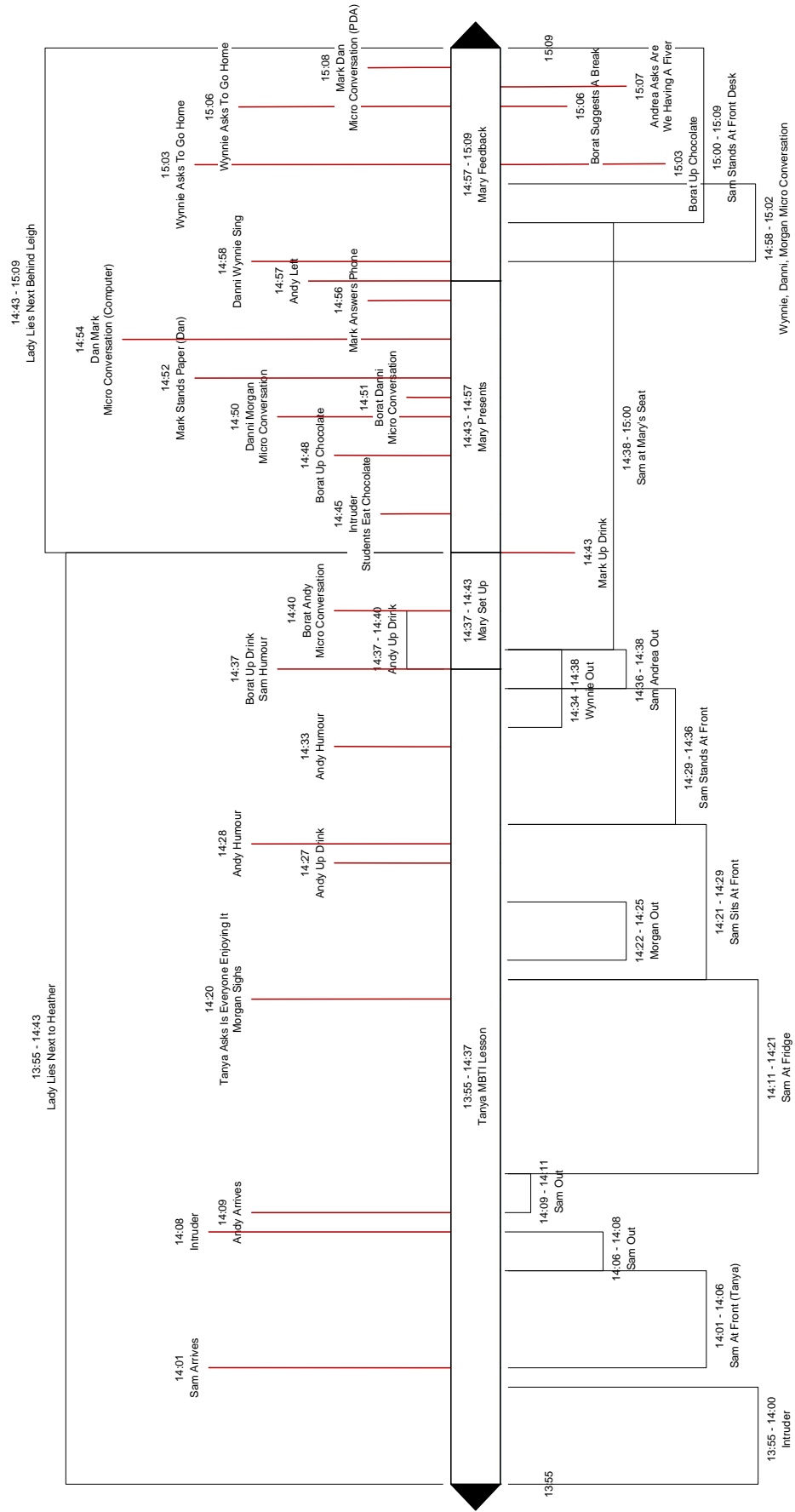

Figure 119. Temporal map for teaching period 5.3.

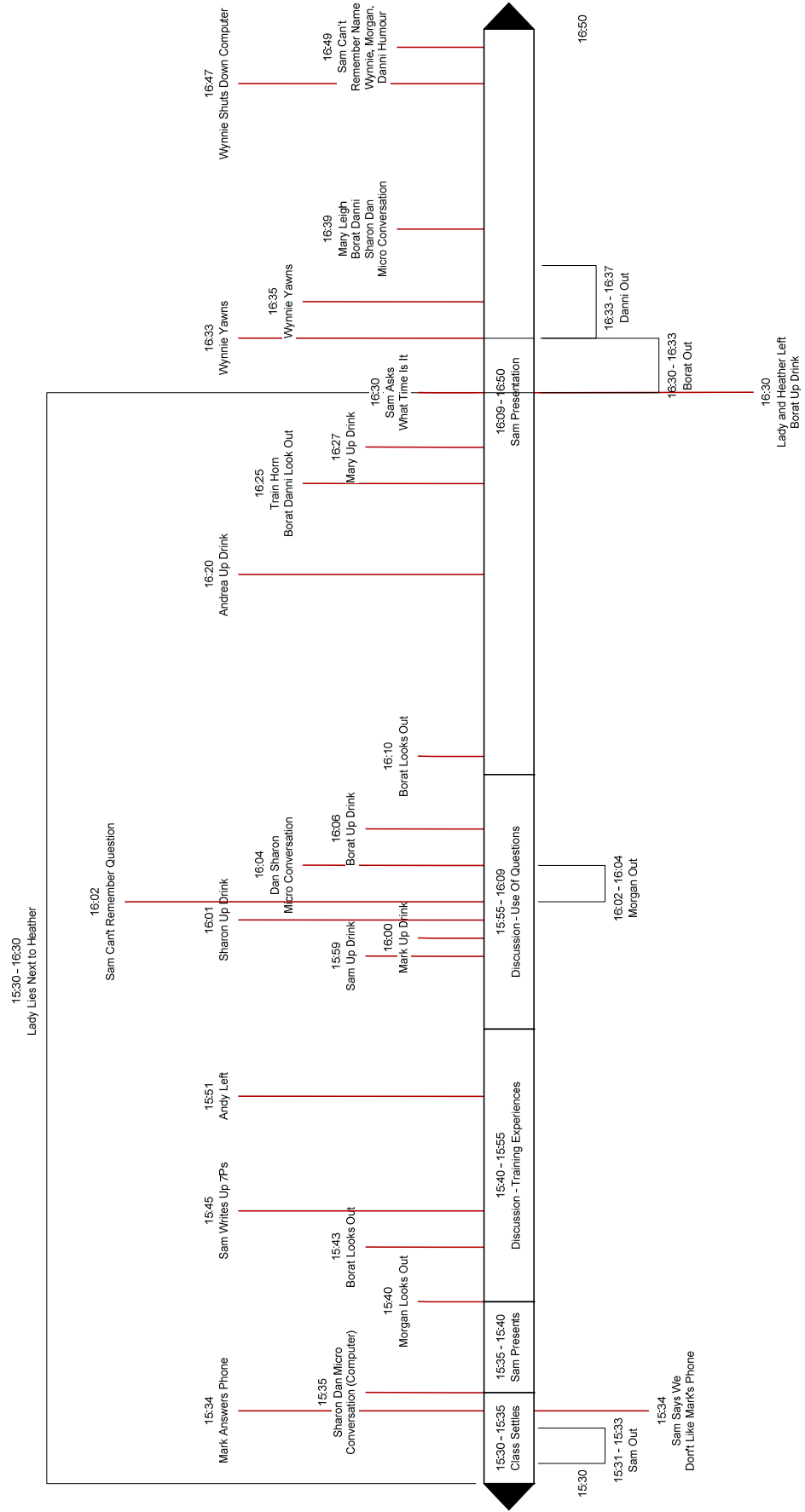

Figure I20. Temporal map for teaching period 5.4.

Day 6, Wednesday, 14 February, 2007

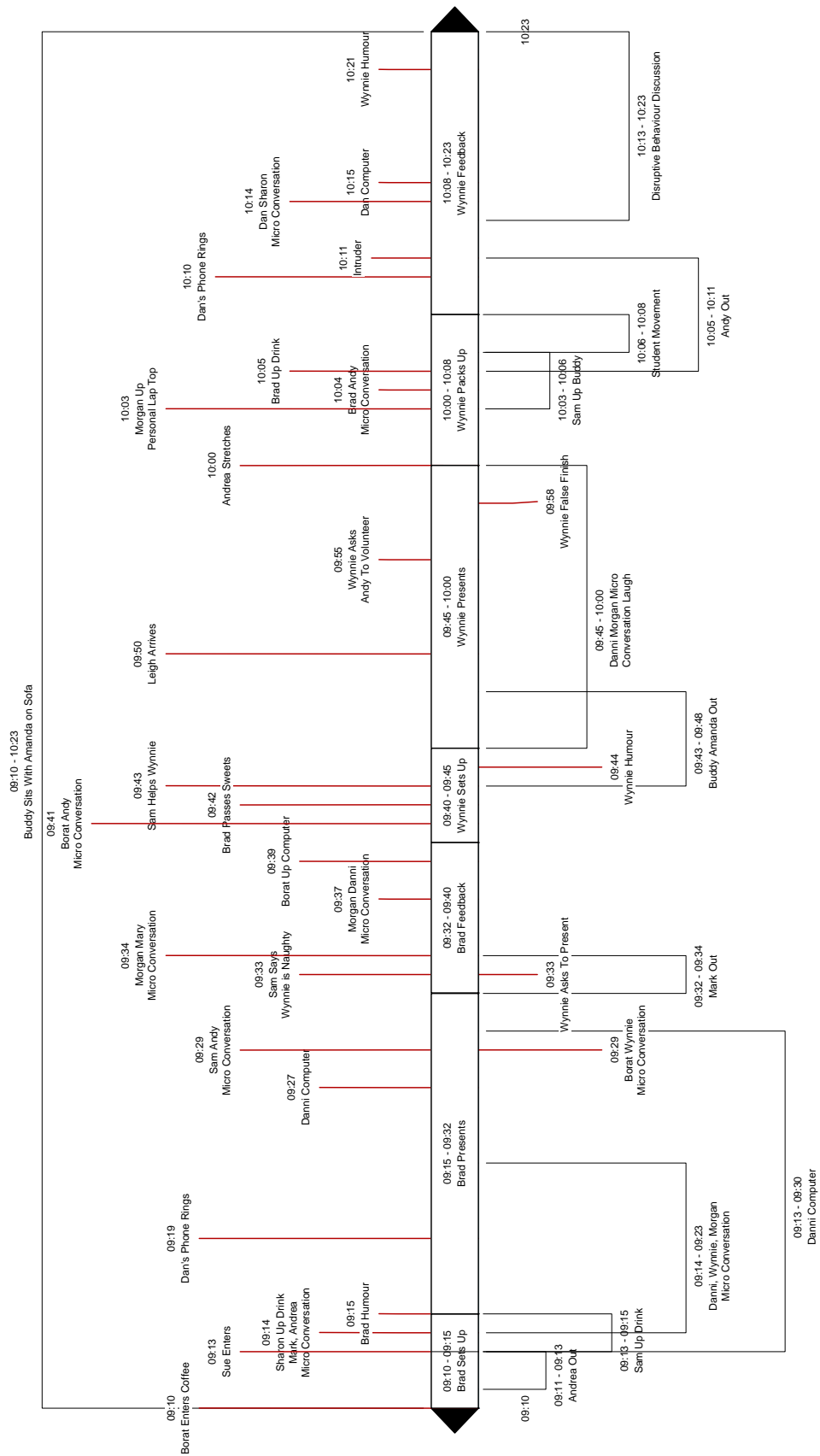

Figure I21. Temporal map for teaching period 6.1.

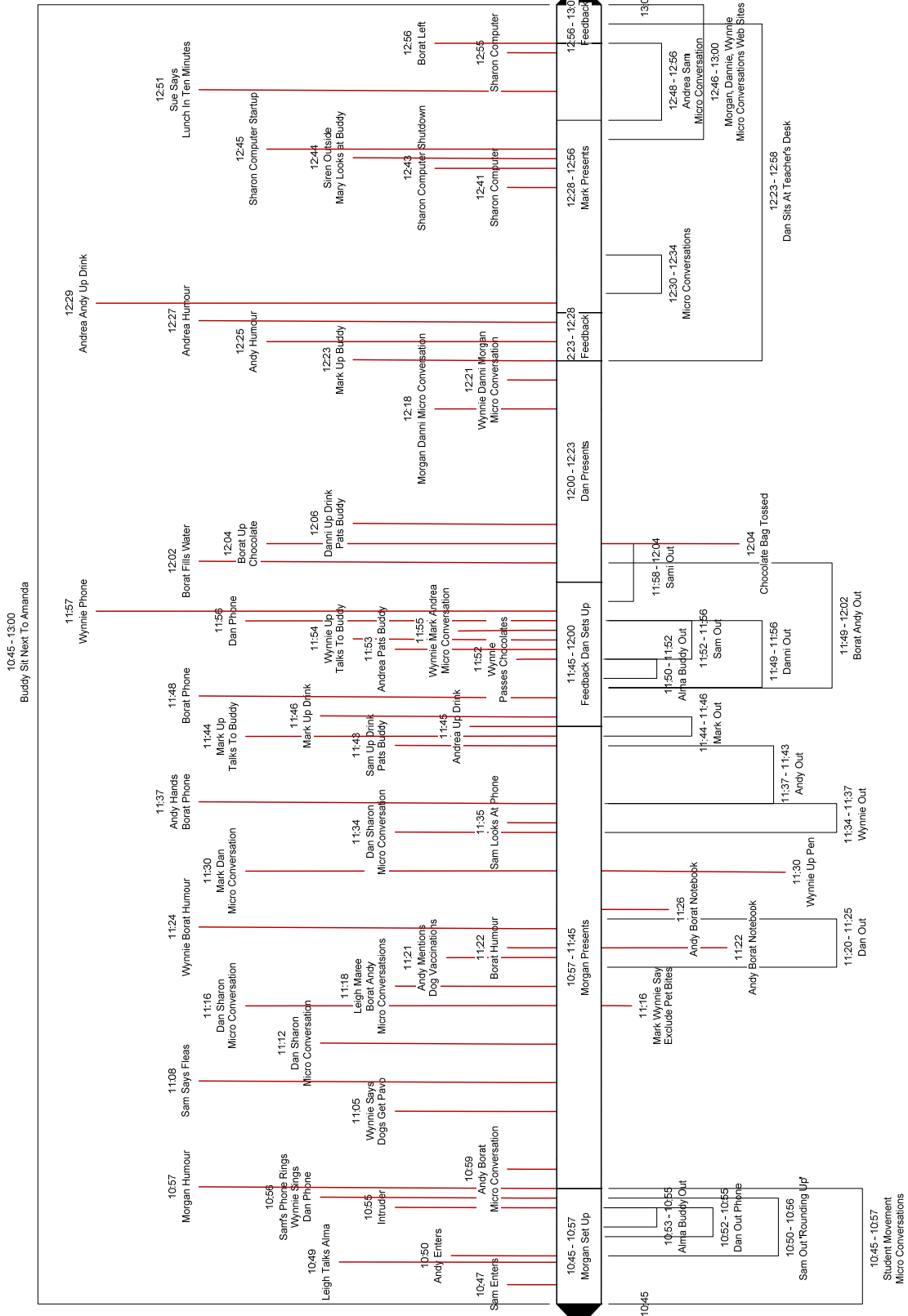

Figure I22. Temporal map for teaching period 6.2.

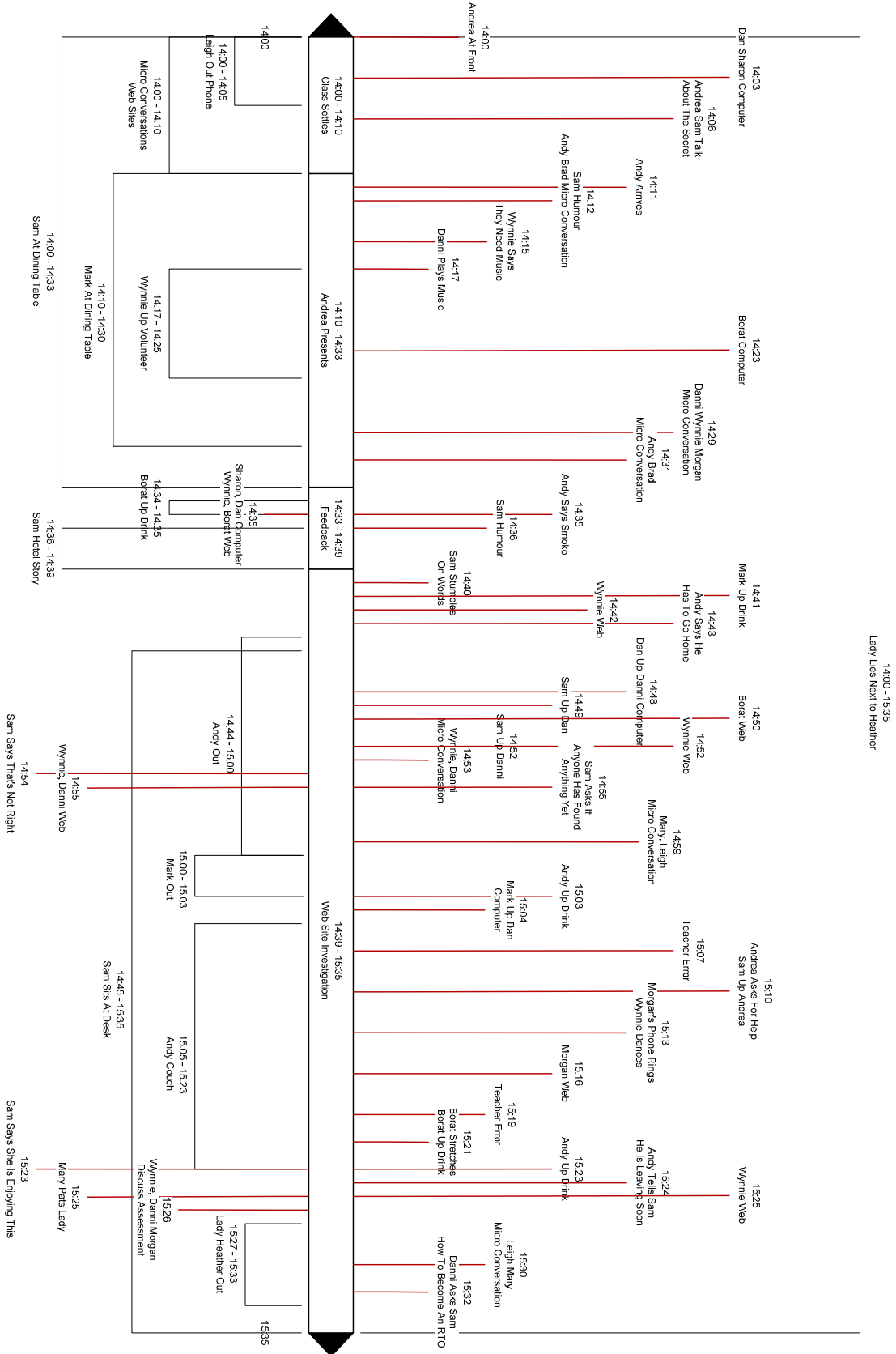

Figure I23. Temporal map for teaching period 6.3.

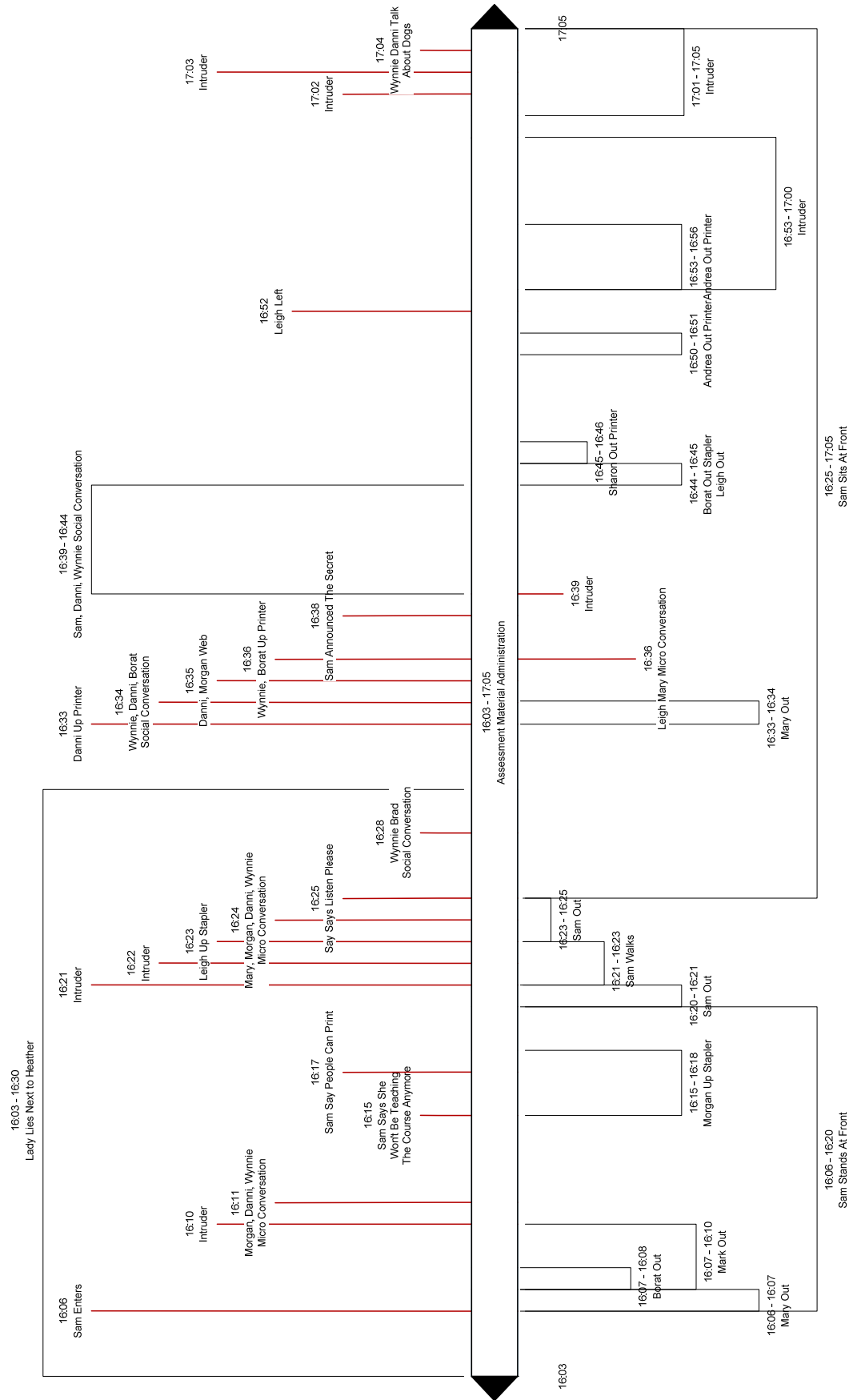

Figure I24. Temporal map for teaching period 6.4.

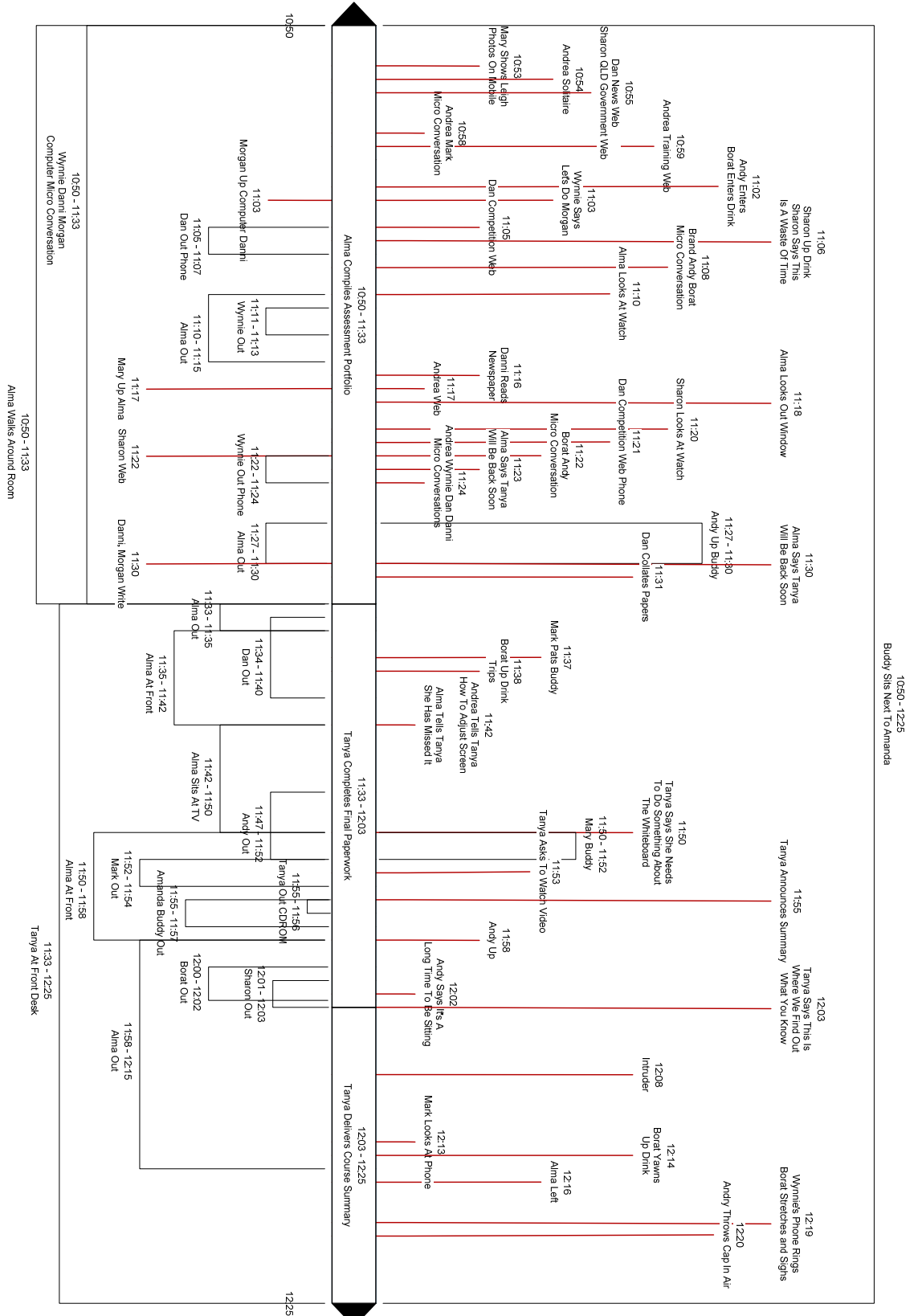

Figure I26. Temporal map for teaching period 7.2.

APPENDIX J: STATISTICAL ANALYSIS OF REPERTORY GRID DATA

The principal method of analysing data arising from the repertory grid technique was the use of computer software to employ statistical methods. These methods included bivariate statistics to examine the relationships between constructs, elements and principal component analysis to compress constructs to a smaller number that would account for the spread of data, and cluster analysis to examine natural groupings amongst constructs and elements, and the similarities and differences they shared. Whilst there are a number of software programmes available for the statistical analysis of repertory grids, Idiogrid (Grice, 2007) provided a comprehensive suite of statistical methods that was affordable, ran under the Windows operating environment, and produced output that could be exported into formats for reporting. Cluster analysis and the creation of dendograms were not available in Idiogrid (Grice, 2007) and were created using the software programme GridSuite (Bacher & Fromm, 2004).

Easterby-Smith, Thorpe and Holman (1996) argue that the statistical methods used for analysing grid data are mostly concerned with exploring the variations amongst and within the data, rather than the similarities. However, Easterby-Smith, Thorpe and Holman (1996).and Fransella and Bannister (1977) caution there is the potential that the methods used may increase the distance between the researcher and that being researched. Thus, to avoid compromising the repertory grid data, Gammack and Stephen (1994) suggest that any statistical analysis must be viewed alongside a qualitative appreciation of the data. This was achieved by writing thick description of the constructs elicited from the interviewee's perspective and referencing the grid to transcripts of the interview. As

suggested by Easterby-Smith, Thorpe and Holman (1996) this allowed the researcher to move between the data, interviewee and the researcher's interpretation of that data.

Bivariate Statistics: Construct and Element Correlations

Bell (2006) suggests a method for revealing patterns within grid data by determining the correlation between constructs and elements. This also provided the basis for further statistical analysis including cluster analysis and principal component analysis. Bell (2006) also suggests that an analysis of the construct and element correlations provided a measure of cognitive complexity, helps reveal how the constructs factored in people's interactions and perceptions of others. It therefore provided a practical way of viewing their construct maps.

According to Motulsky (1999) when two variables, either constructs or elements on a grid, vary together, they are said to be correlated with each other and share a relationship beyond what is expected by chance alone. Therefore, correlation can be seen as a statistical measure of the relationship between two variables in a set of data that can help reveal patterns of relationship amongst the grid data. Correlations between pairs of elements and between pairs of constructs in each set of grid data, were computed as Pearson product-moment correlation coefficients using Idiogrid (Grice, 2007) software, and matrices were produced that were then analysed for relationships.

The Pearson product-moment correlation coefficient r , is a widely used measure of correlation that expresses the linear relationship between constructs and elements as a number between $r = -1.00$, which indicates a negative linear relationship, and $r = +1.00$, which indicates a positive linear relationship (Easton & McColl, 2010). According to Easton and McColl (2010) where two variables are not

correlated, that is where $r = 0.00$, it can be said that the variables do not share a linear relationship, however they may share a non-linear relationship.

The statistical significance of the correlation coefficient was determined by calculating the p values for the correlation coefficients. The p value is a measure of probability ranging from zero to one. Where the p value is small, the difference is unlikely to be by chance and the correlation can be said to be significant (Motulsky, 1999). A threshold value of $p < 0.05$, which has been widely adopted by statisticians, means that there is only a 5% chance that the correlations are coincidental (Grice, 2003; Motulsky, 1999).

Approximate p values were calculated by conducting randomisation tests using Idiogrid (Grice, 2007). According to Grice (2003) during the randomisation tests the constructs in each grid were randomly shuffled and the p values for the correlation coefficients for the randomised grid were then recomputed. This process was repeated 1,140 times to produce the final p values for the correlation coefficients. Through testing it was found that increasing the number of repetitions did not produce differing results.

Illustrated in Table J1 are the results of a sample randomisation test that show correlations of $r = 0.49$ or greater were observed with a frequency of approximately 5% ($p = 0.05$). Therefore, correlations of $r \geq 0.49$ and $r \leq -0.53$ in this grid can be considered statistically significant at the 0.05 level, and are therefore one-tailed.

Principal Component Analysis

Construct and element correlation matrices produce a lot of data that is often difficult to understand, and contain a significant amount of variance. According to Darlington (2008) factor analysis is a statistical data reduction technique that is used

Table J1

Sample Randomisation Test

Critical values	Upper value	Lower value
p ~ 0.001	0.74	-0.81
p ~ 0.010	0.67	-0.69
p ~ 0.025	0.60	-0.60
p ~ 0.050	0.49	-0.53
p ~ 0.100	0.41	-0.41
p ~ 0.150	0.33	-0.32

Note. All p-values are 1-tailed, corresponding to the lower and upper critical values.

to describe this variance in terms of underlying factors by revealing patterns and relationships amongst the variables. Garson (2008) suggests that factor analysis therefore may be used to reveal the latent structure or dimensions of the variables within the repertory grid data.

According to Garson (2008) the most common forms of factor analyses are: common factor analysis, which is generally preferred for causal analysis; and principal component analysis, which is generally preferred for reducing data containing a large number of measured variables into a smaller set of understandable and independent components. Garson (2008) points out that whilst common factor analysis aims to reveal the least number of factors that account for the variance in the grid; principal component analysis aims to reveal the set of components or factors that account for all the variance in the variables in the grid.

Put simply, if correlations are about revealing the patterns of relationships within the grid data, principal component analysis is about understanding those patterns by revealing the underlying factors at play.

The principal components for each set of grid data were identified and analysed using Idiogrid (Grice, 2007) software to apply a mathematical computation that translated the constructs into a smaller number of hypothetical variables to explain the variance in the data. Garson (2008) and Stewart and Stewart (1980) describe a number of methods to determine the number of components that should be extracted without losing the underlying meaning of the data. However, they argue that in the analysis of grid data it is usual practice to use only the first two components that sacrifice some detail, yet make visual understanding of the grid data easier by limiting the number of components to the ones where the dimension of meaning that is readily comprehensible (Garson, 2008; Stewart & Stewart, 1980). Garson (2008) argues that it is the researcher's job to use a combination of methods to determine the number of components to be extracted, and to determine the solution that establishes the most meaning of the components for the researcher's purpose.

Three methods were used in this study to determine the number of components to be extracted from each grid. These methods were: interpretation of the amount of variance accounted for by the principal components; interpretation of the eigenvalues; and interpretation of the scree plots.

Table J2 shows the total number of components extracted from the construct correlation matrix for an individual's grid, and the amount of variance explained by each component. In this example there are nine constructs, and thus nine components would be needed to explain 100% of the variance in the data. This table

Table J2

Sample Eigenvalues and Component Variance for Grid Data

Component	Eigenvalue	% Variance	% Cumulative variance	Scree plot
PC_1	4.77	52.98	52.98	*****
PC_2	1.65	18.37	71.35	*****
PC_3	1.23	13.67	85.01	****
PC_4	0.46	5.11	90.12	**
PC_5	0.38	4.23	94.35	**
PC_6	0.25	2.75	97.10	**
PC_7	0.11	1.24	98.33	*
PC_8	0.08	0.85	99.18	*
PC_9	0.07	0.82	100.00	*

also shows that two principal components account for 71.35% of the total variance in the grid. As each of the remaining components accounts for a small amount of the total variance, Easterby-Smith, Thorpe and Holman (1996) suggest they may be considered of less importance and have less significance to the person's construct map, and therefore may be safely ignored.

According to Garson (2008) the eigenvalue for each component is a measure of the variance accounted for by that component, expressed as a value of the total number of components. Garson (2008) explains that the eigenvalue is therefore a ratio of the explanatory importance of a component with respect to the variables, and statistically is calculated by summing its squared loadings for all variables.

According to Garson (2008) variables are standardised to have means of 0.00 and variances of 1.00, and therefore an eigenvalue of less than 1.00 means that a component accounts for less than one construct and can be safely ignored. This is known as the Kaiser criterion, or K1 rule (Garson, 2008).

According to Grice (2003) the Cattell Scree Test shows the relative size of the eigenvalues and is used to identify the components that account for the greater amount of total variance. Plotted on the x axis of the scree plot are the components and the corresponding eigenvalues are plotted on the y axis. Accordingly to Garson (2008) where the curve drops off sharply and makes an elbow, all remaining components can be ignored.

The principal components that were extracted from each grid were hypothetical in nature, and as suggested by Rummel (1967). It was through the interpretation of how heavily each construct was loaded on each component that the meaning of each was understood. For example, Table J3 shows the factor loadings for eight constructs on two principal components extracted from an individual's grid. The first component appears to be heavily loaded on Constructs 5, 6, 7, 8 and 9, and to a lesser extent on Construct 3. These factor loadings appear to suggest that this component could be described in terms of approachability, trustworthiness, participative, positive energy and emotion, outgoing, and people who are grounded and personally motivated to attend the course. The extroverted facet of this construct is supported by the heavy negative loading on Constructs 1 and 4. These factor loadings may also suggest that the contrasting pole of this component may be described in terms of people who are seen as distant and removed, less trusting, reserved, holding back, aloof, and obligated to attend. These descriptions suggest

Table J3

Sample Factor Loadings

		Construct		Factor loading	
		Emergent pole	Implicit pole	PC 1	PC 2
1.	Active	Quiet		0.06	-0.89
2.	Experienced Altruistic	Novice Seeking Altruism		0.12	-0.33
3.	Excited Naïve	Content Experienced		0.64	-0.67
4.	Committed Passion	Distant Removed		0.22	-0.88
5.	Approachable	Wary		0.76	-0.34
	Trustworthy				
6.	Happy Participative	Holds Back		0.70	-0.51
7.	Down-to-Earth	Aloof		0.88	-0.24
8.	Wants to be Here	Needs to be Here		0.80	-0.37
9.	Accepting Helping	Vulnerable		0.78	0.41

that this component may be labeled Positive Trustworthy Social—Critical Distant Reserved. The second component appears to be heavily loaded only on Construct 9, which suggests that this component may be described in terms of compassion, acceptance and respect, and that the contrasting pole may be described in terms of self-concern, aggressive and conflict creators. These descriptions suggest that this component may be labeled Compassion Respect—Aggressive Insensitive.

According to Feixas and Alvarez (2006) the components once extracted do not share a correlation with each other, and as such represent distinct and different

factors. The components were then used as axes and constructs and elements were plotted against them and displayed as a biplot using Idiogrid (Grice, 2007). Figure J1 illustrates a sample biplot that visually represents a person's construct space. In a similar manner to that suggested by Easterby-Smith, Thorpe and Holman (1996), the biplots revealed a graphical picture of each person's construct space by visually representing the relationship of constructs to constructs, known as inter-construct relationships, elements to elements, known as inter-element relationship, and elements to constructs. The biplots were also useful in determining the level of complexity of people's concept map and thinking. For example, Easterby-Smith, Thorpe and Holman (1996) suggest that elements and constructs that are tightly clustered together may indicate a simple concept map, and those that were dispersed across the biplot, may indicate a complex concept map.

In the manner suggested by Easterby-Smith, Thorpe and Holman (1996), the relative importance of constructs to elements was examined by looking at their proximity to each other. The closer an element appeared to a construct the more important that construct may have been in defining that element in terms of the individual's construct space. Further meaning of the hypothetical components was also derived by interpreting where the elements and constructs lay when plotted on the biplot as suggested by Easterby-Smith, Thorpe and Holman (1996). The proximity of an element or construct to the centre helped determine how clear or well defined it was in terms of the individual's construct space. Elements or constructs that were close to the centre of the biplots, indicated that an individual was not clear about where they saw that element in relation to the two components. These elements were therefore be considered of less importance to that person's construct system

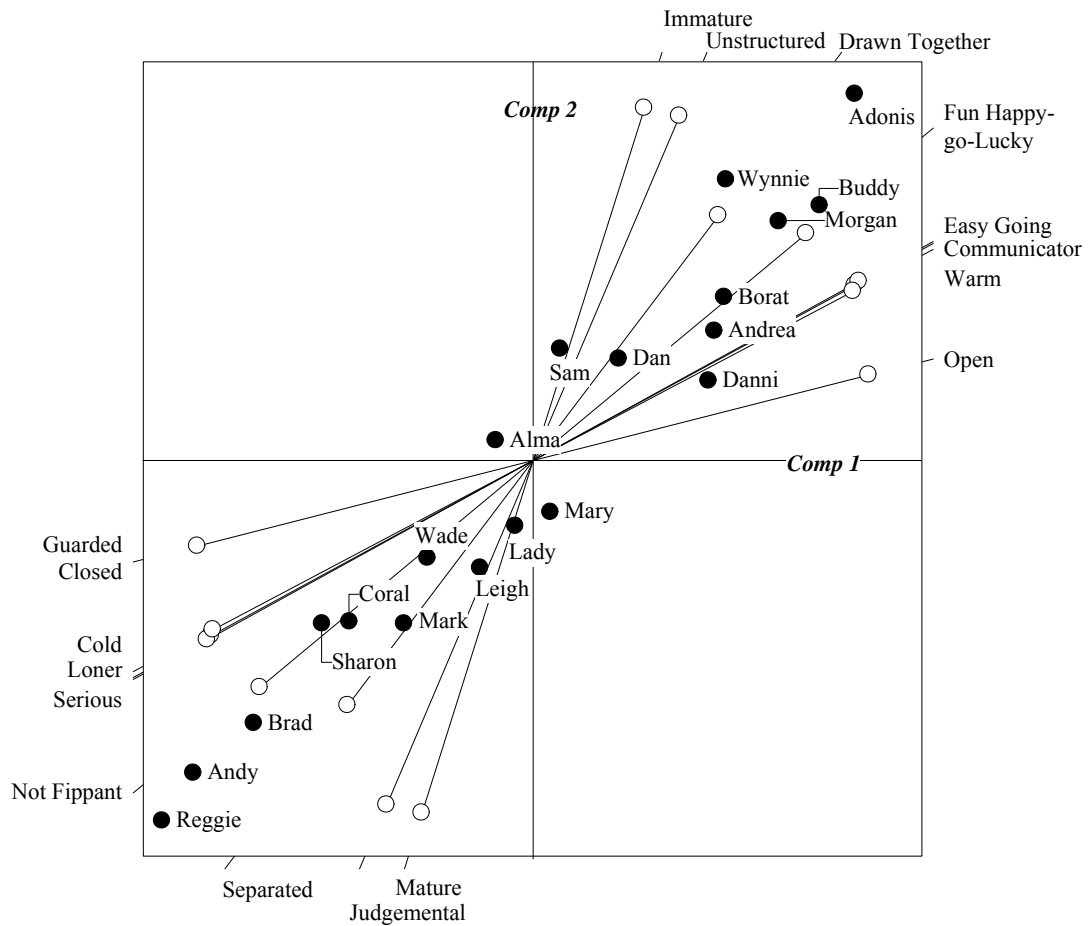

Figure 11. Sample biplot representing a person's construct space.

Cluster Analysis

The final statistical method that was used for analysing the repertory grid data was cluster analysis. Stewart and Stewart (1980) suggest that cluster analysis, which is also known as dendritic analysis, is often used as an alternative to principal component analysis. In this research it is used to provide another way to view an individual's construct space. According to Stewart and Stewart (1980) one of the main advantages in using cluster analysis is that none of the detail of relationships between constructs and elements is disregarded, as is the case when using principal component analysis. Cluster analysis also worked towards greater differentiation and definition of elements and constructs, unlike principal

component analysis that, as suggested by Stewart and Stewart (1980), collapsed some of their meaning. However, unlike principal component analysis, cluster analysis required some visual inspection and interpretation in order to understand these relationships (Stewart & Stewart, 1980).

In this research, cluster analysis was undertaken using GridSuite (Bacher & Fromm, 2004) software. In the manner suggested by Easterby-Smith, Thorpe and Holman (1996) and Stewart and Stewart (1980), it showed the statistical similarity between the constructs and elements, and re-sorted those that were closely connected together by placing them next to each other. A line was drawn connecting similar elements and constructs to form clusters in the manner described by Stewart and Stewart (1980) that created a hypothetical element or cluster. Families of clusters were formed by calculating the similarity between hypothetical clusters, until all of the elements and constructs were accounted for. The results of each cluster analysis were then displayed as a dendrogram that included a scale indicating the level of similarity between clusters.

Above each branch in the dendrogram is displayed the z-score that according to Grice (2003) represents the number of standard deviations from the mean and may be used to determine the statistical significance of the relationship between the constructs or elements. Easterby-Smith, Thorpe and Holman (1996) suggest that where the z-score decreases, it may indicate that the two clusters are separate and distinct from one another, and the integrity of including them in larger families of clusters may be doubtful.

In the manner suggested by Easterby-Smith, Thorpe and Holman (1996) the major branches and divisions were then interpreted to explore the hidden meaning behind the clusters. For example the dendrogram in Figure J2 shows the similarity

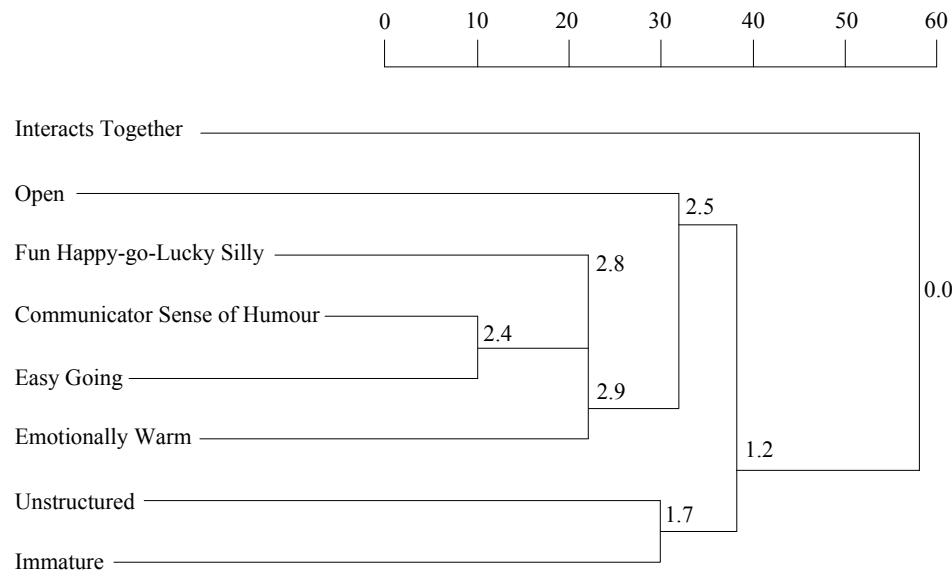

Figure J2. Sample cluster analysis of constructs.

between the constructs and elements derived from the cluster analysis of an individual's grid data. This dendrogram shows that the first cluster of constructs is formed between Communicator Sense of Humour and Easy Going. A larger family cluster is formed between these two constructs and Fun Happy Go Lucky Silly and Emotionally Warm, which may be hypothetically labelled Compassionate. However, the relationship between this larger cluster and the construct Open does not appear significant as the z-score for that branch decreases to 2.5. Another separate cluster is formed between the constructs Unstructured and Immature that also appears unrelated to the construct Open and the hypothetical Compassionate cluster, as indicated by the z-score that decreases to 1.2. The construct Interacts Together appears unrelated to all other constructs and clusters. This new understanding of the relationship between constructs allowed the researcher to reflect back on the results of the principal component analysis, revisit the original hypothesis of the two components extracted, and reconsider the original

understanding of Openness in the Open Compassionate component. In contrast, the dendrogram appears to confirm the hypothesis that the second component that was extracted may be labelled Spontaneous.

The dendrogram at Figure J3 shows that there are several small clusters amongst the elements. However, it appears that there are two major clusters formed at the top and bottom, which are separated between Sam and Leigh. These two clusters may be confirmed by reviewing how these elements are displayed on the biplot.

Easterby-Smith, Thorpe and Holman (1996) suggest that some clusters may be formed from mathematically correlating constructs and elements, however these may not fit naturally and explanations for this were explored by referring back to how the person originally described the constructs in the interview transcript. Additionally, a sounder hypothesis was formed for the patterns of relationship within the grid data by using a combination of bivariate statistics, principal component and cluster analysis.

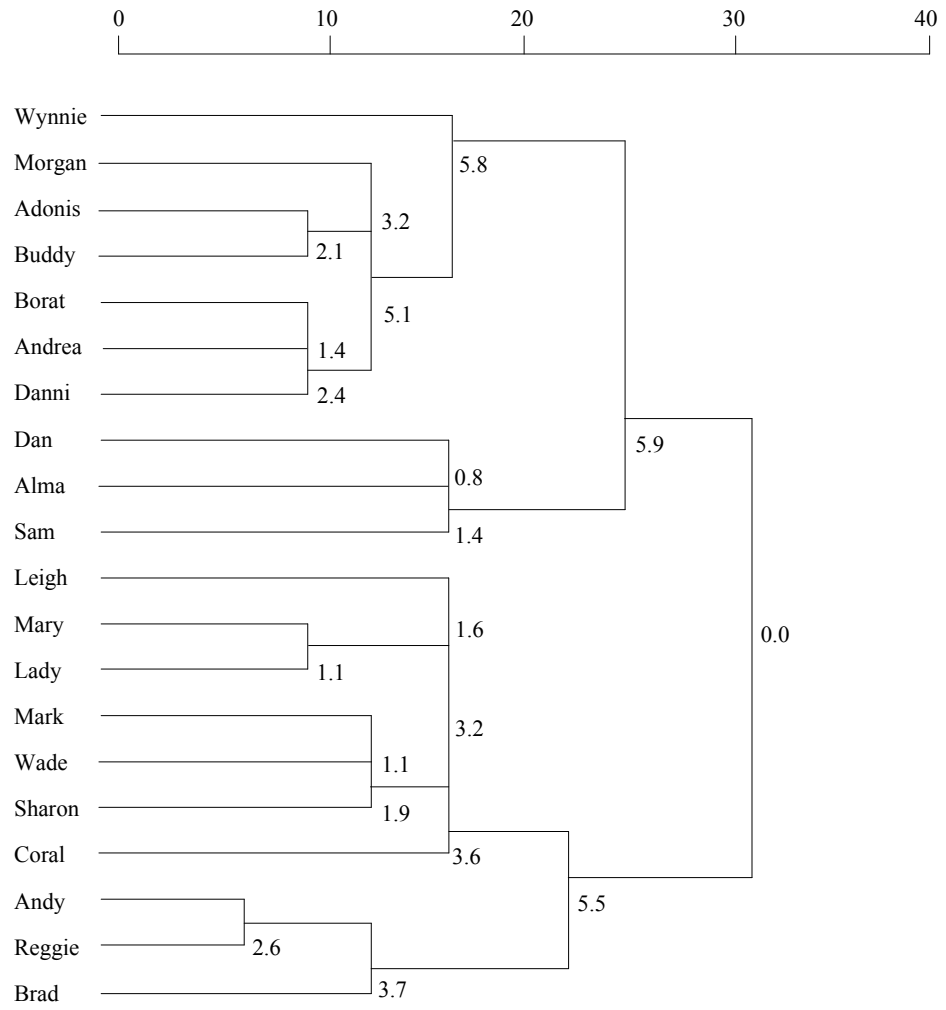

Figure J3. Sample cluster analysis of elements.

APPENDIX K: TEACHER, VISITOR AND STUDENT BEHAVIOURS

The analysis of emergent codes from the observational data revealed patterns within the behaviour of the dogs and people's interaction with them that are reported in chapter 4. It also revealed patterns of student, teacher and visitor behaviours that may help inform the answers to the research questions by providing a deeper understanding of the context within people interacted with the dogs. These patterns of behaviours were characterised by lesson types and teaching style, visitors, social behaviours, repeated actions, student voices, teacher voices, student engagement and additional observations.

Lesson Types and Teaching Style

The teachers used three types of lessons to deliver the course: presentation lessons; assessment lessons; and assessment task lessons. During presentation lessons the teachers used electronic slide displays to support the lecture style presentation of information. The teachers stood behind a chair at the front of the room and often leaned on the desk in front of them. They looked down to read from the computer screen, and from time to time, reached down and pressed the keyboard to advance the slide display. During some of these presentations the teachers walked over to the whiteboard and wrote notes. On several occasions the teachers read from the student workbook folders, referred students to particular pages and instructed students to read from them. The teachers intermittently asked questions of the group and on a few occasions, engaged students in short group discussions.

A variation of this lesson type saw the teachers sit down and read from a document on the computer, which was also displayed on the large screen at the front of the room. Another variation saw students browse through web sites and locate documents that they then printed. A further variation included short teacher-lead

brainstorming exercises when the teachers posted responses on the whiteboard. An additional variation saw students form triads with people seated next to them to complete small group exercises. After they had completed an exercise, a representative from each triad presented that group's findings to the class. On some occasions the teachers walked around the room, watched students, and occasionally paused to answer individual questions.

During assessment lessons, students completed assessment exercises. The teachers sat at the desk at the front of the room and displayed documents on the large screen. The teachers looked down at the screen as they read from these documents, asked questions and occasionally glanced over the top of the computer screen to look at students. On some occasions students offered answers, and when they did not, the teachers provided answers. The teachers then typed information into the documents, which students copied into the documents on their own computers. The teachers often completed Andy's assessments and used them as examples that were displayed on the large screen. A variation of this lesson type saw students complete assessment exercises either independently or with students who were sitting near them. Another variation saw students work independently to draw diagrams that represented their understanding of the relationship between different facets of the subject being assessed. Students attempted to complete the assessment unaided, however after several minutes the teacher drew a diagram on the whiteboard, which students used pen and paper or their computers to copy.

A third type of lesson referred to as assessment task lessons, was constructed from a mixture of presentation and assessment. Tanya described this type of lesson by saying that even though it was usual to teach and then assess, it was also possible to, "assess as you train." She said that completing the assessment task would, in

itself, provide students with the learning. She further explained that this method was a quick way of completing assessments. On a separate occasion, Alma introduced this type of lesson by saying, “I reckon you learn more by doing it, what do you think?” During these lessons the teachers sat at the front desk, used the computer to demonstrate how to complete the assessments, and asked questions or provided explanations. Students worked independently or in pairs to complete the assessments by copying the teachers’ example. The teachers often completed Andy’s assessments and used them as examples that were displayed on the large screen.

A variation of this lesson type included a role-play scenario. The teacher first created a checklist on the whiteboard, which one student typed, printed, and distributed. The teacher, with the help of a volunteer student, then acted out a simulated situation. After this, the teacher completed the feedback checklist on the whiteboard and students copied the answers onto their checklists. Another variation saw students copy the teacher as he demonstrated how to use Microsoft Publisher software to make an advertising brochure.

A further variation saw students present sample lessons over two days, referred to as student presentations. The content of the sample lessons differed for each student, however the format remained consistent. A short set up time of between five and fifteen minutes allowed each student to load presentation material onto the computer at the front of the room, and to organise their teaching materials. At the same time, the remaining students engaged in social conversation and occasionally left the room or stood up and got a drink. Students delivered their sample lessons over a period of twenty to thirty minutes. After this the teacher and remaining students completed feedback sheets whilst the presenting students packed

up their materials. The teacher then discussed feedback with students over a period of ten to twenty minutes. During several student presentations some remaining students worked on their own presentations or accessed web sites.

There were periods during the course when the material presented was not relevant to the qualification; when students engaged in administrative tasks of checking, sorting, collating and signing documents; and when the teachers showed students resources on the internet as students attended to personal needs. These periods are referred to as void lessons. During void lessons the teachers provided minimal direction to students, and limited direct teaching, learning or assessment relevant to the course outcomes took place.

Visitors

There were 61 occasions on which eight different people entered the classroom: Alma, Johannes, Narelle, Sally, Sarah, Tanya, Tanya's son and one unknown person. There were only three periods when no visitors entered the classroom: period two and four on day five, and period three on day six. The pattern of visitor behaviours was characterised by: assisting students, catering, delivery, maintaining equipment, delivering messages to students, attending to personal needs, speaking to students, speaking to teachers and working.

Assisting students was distinguished by people who delivered printing and equipment, and resolved technical problems. Catering was distinguished by people who delivered food, removed empty food trays, and refilled cups on the coffee machine. Delivery was distinguished by people who delivered goods. Maintaining equipment was characterised by people who entered the room to attend to the printer, replace the toner cartridge, place a towel where water was leaking, and to look into the room. Delivering messages to students was distinguished by two

people who delivered phone messages to students. Attending to personal needs was distinguished by people entered the room for reasons that appeared personally motivated. Reported at Table K1 are behaviours that exemplifying attending to personal needs. Speaking to students was distinguished by people who entered the room to speak privately with individual students. Speaking to teachers was distinguished by people who entered the room to speak privately with the teachers. Working was distinguished by occasions when visitors worked privately whilst in the room.

Reported at Table K2 is the frequency distribution of visitor behaviours. The most frequent behaviour was attending to personal needs, which occurred on 18 occasions. This behaviour was most frequently exhibited by Tanya. Another frequent behaviour was assisting students, which occurred on 13 occasions. This behaviour was most frequently exhibited by Johannes, which suggests that the assistance most often provided to students by visitors was computer support. The least frequent behaviours were delivery of goods, delivering messages to students, and entering the room to speak privately and briefly to students.

There were only two occasions when visitors apologised to students for entering the room. The first was when Tanya entered the room during the second teaching period on the third day, apologised to the students and explained that she was looking for a chair. She then walked to the back of the room, picked up a chair and smiling, looked behind her and left the room. The second occasion was when an unidentified female entered through the office sliding door during the fourth teaching period of the fourth day, walked across to the water cooler, turned around to look at the teacher and mouthed, "Sorry." She then filled a cup with water and left through the office door.

Table K1

Behaviours that Exemplify Attending to Personal Needs

Visitor	Behaviour
Alma	Entered the room holding flowers and said, "Look at what I've got." Asked Sam if she was finished,
Johannes	Looked around holding cables.
Narelle	Removed stray dogs
Sally	Spoke to Borat after he had filled the water cooler and said, "You can have a couple of freebies for that."
Tanya	Placed milk in the fridge. Put rubbish in the bin. Retrieved a remote control. Handed chocolate bars to Borat Removed a chair from the room.
Unknown	Got a drink from the water cooler and coffee machine.

The high proportion of visits that were related to the visitors' personal needs is contrasted with the small number of visits that were related to student needs. Additionally, 20% of visits were related to maintaining equipment, and only 13.3% were related to the needs of the teachers.

Social Behaviours

One pattern of behaviours was characterised by aspects of socialisation. These aspects of socialisation were distinguished by: hellos and goodbyes;

Table K2

Frequency Distribution of Visitor Behaviours

Visitor	Assisting students	Catering	Delivery	Maintaining equipment	Delivering messages to students	Attending to personal needs	Speaking to students	Speaking to teacher	Working	Frequency	Distribution
Alma						2				2	1
Johannes	8			4		4	1	2	5	24	6
Narelle	3	2	2		2	1		2		12	6
Sally	1			1		1				3	3
Sarah		2						2		4	2
Tanya						7	2	1		10	3
Tanya's son	1									1	1
Unknown		3				3		1		7	3
Frequency	13	7	2	5	2	18	3	8	5	63	
Distribution	4	3	1	2	1	6	2	5	1		

behaviours that suggest the establishment of spoken and unspoken rules regarding expected and acceptable behaviour; and the formation of social groupings and micro-conversations.

Hellos and Goodbyes

One pattern of behaviours that characterised socialisation, was distinguished by the way people were introduced to each other, the way they used each other's names, and the way they greeted and farewelled one another each day and at the end of the course. For example on the first day Tanya briefly introduced herself and invited students to briefly introduce themselves. Seated in their chairs, students in turn stated their names and occupations. Sam was seated at the back of the room and was briefly introduced an hour after the start of the course and was invited to deliver her presentation. There were no nameplates or badges used to assist people in remembering others' names. On the afternoon of the first day of the course Alma introduced herself to the group by saying that she was an occupational therapist, and asked people if they knew what an occupational therapist was. However, she did not ask students for their names or for them to introduce themselves to her. Morgan joined the class on the second day and was not introduced to any member of the class.

How people were introduced to each other was reflected in the way they used others' names. For example during the first day Andy started to refer to Borat by the nickname "Bruno," and continued to do so throughout the course. Andy's use of the nickname, "Bruno," however, went unnoticed by the teacher until the afternoon of the fifth day when several students explained to her the origin of the nickname. Similarly Sam apologised on several occasions for not remembering people's names. For example, on one occasion when speaking to Reggie she said, "Sorry, I can't remember your name. I'm really bad with names." Similarly, on the morning of the fifth day when Sam asked who was doing their presentation, she apologised for not remembering Andrea's name. Morgan, Danni and Wynnie

looked across at Andrea and told her that she should bring a sign or a t-shirt with her name printed on it. On the morning of the fourth day Sam asked Andy what his last name was, and during the afternoon of the sixth day Danni asked Leigh what her last name was. On the morning of the last day Andy, who read aloud a name on the top of a sheet of paper he had been handed said, "Andrea, who's Andrea," and Andrea put her hand up and identified herself to Andy.

Only a few students on a few occasions said, "Good bye," to others at the end of the day's lesson or at conclusion of the course. Only Wynnie said, "Good bye," to Sam at the end of the course.

Establishing Ground Rules

Immediately before the afternoon break on the first day, Alma facilitated a brainstorming session with students in an attempt to create a set of agreed ground rules to guide normative behaviour amongst the group. This occurred later in the day rather than earlier when it is traditionally expected. It also occurred as part of the lesson content to teach people how to manage diversity, rather than creating rules for the purpose of establishing expected group behaviours. Nevertheless, amongst the rules established was an absence of those concerning the dogs, and those concerning student behaviours such as getting up to get a drink, leaving the room, printing and the use of mobile phones. Coral suggested the inclusion of regular breaks, however this suggestion went unacknowledged. Unexpectedly, Alma erased the ground rules soon after writing them on the whiteboard. This appeared to diminish their importance and value to students. The following excerpt from the running records provides a detailed account of the event:

6/02/2007 15:30:07

Alma leans forward and moves the slide forward as she asks a question of the group. One of the girls at the back of the room murmurs a quiet response. Alma gets out of the chair, points towards the screen and says, "We are going to establish ground rules." At that time, Lady gets up and stands next to the table I am working at, facing the front of the room. Alma moves towards the whiteboard and writes the heading "ground rules," and asks the group for some examples. Mary and Mark offer some suggestions and Lady lies down with her head up at the back of Mark's chair which is still angled towards the front of the room. Mark makes a comment that opinions are like arseholes, that everyone has one, and everyone thinks everyone else's stink. There is a quiet snicker around the room. Danni says, "Thanks for sharing that with us," quietly. Mark asks her to repeat it and she does a little louder.

6/02/2007 15:33:55

Alma offers the suggestion of *punctual*. Borat says it wasn't his fault, it was the train. Alma writes *punctual* on the whiteboard and then paces back in front on the teacher's desk. Reggie suggests *treated equally* and Alma moves to the whiteboard and writes this on it too, and then moves back in front of the teacher's desk, holding the whiteboard pen. Lady puts her head down pointing towards Helen. Alma asks if there are any other suggestions and Sharon offers one. Alma summarises and explains consequences of ground rules, paces between whiteboard and desk, points towards the whiteboard with a pen. Coral says that she thinks there should be a ground rule that, "We get to stand up for five minutes every hour or so. I doesn't know about others." Alma tells the group that afternoon tea is in ten minutes

and asks if everyone can “hang on” that long. There is a general sigh and stretch around the room. Andrea turns to Mark and quietly tells him that the chair has been pointing in her back.

Social Groupings and Micro-conversations

Another pattern of behaviours that characterised socialisation was distinguished by social groupings and micro-conversations. Micro-conversations were distinguished by short discussions, often of a social nature, that occurred between people who were seated next to each other. They also characterised the social groupings in the room. Coral and Reggie were the only students who did not engage in micro-conversations. During the student presentation lessons these micro-conversations extended to include people who were seated directly across the tables. The social nature of these micro-conversations included clothing, weddings, where people worked, furniture, jobs, mutual acquaintances, property and investments, social plans for the evening and weekend, family and friends, driving experiences, partners, television shows and mobile phones.

This behaviour started during the second teaching period and continued for the remainder of the course. It occurred during all lesson types and did not happen more frequently during one than it did during others. It also did not happen more frequently at different times of the day. There were only four teaching periods when there were no micro-conversations observed: the first and last period on the first day; the last period on the second day; and the first period on the third day. Micro-conversations were most noticeable on the last day of the course.

Repeated Actions

Another pattern of behaviours was characterised by repeated actions. These repeated actions were participants leaving the room, getting printing, getting drinks, using mobile phones, eating and by Reggie who frequently paced around the room.

Leaving the Room

One pattern of repeated actions was distinguished by teachers and students who spontaneously left the room, often unannounced. This behaviour occurred during 24 of the 26 teaching periods. Many student absences lasted between one and five minutes, however several students were outside the class for up to 20 minutes. Many students left the room to retrieve documents that frequently printed from the printer in the reception area outside the classroom. Students also left the room to: make phone calls; get supplies such as paper, cups, staplers; have a cigarette; or visit the bathroom. However, on many occasions it was not always possible to determine the reason students left the room.

Reported at Figure K1 is the frequency of participants leaving the room. This graph shows that this behaviour started during the first teaching period, quickly increased in frequency and was maintained for the duration of the course. This behaviour occurred during all lesson types, including presentations, and did not appear more frequently during assessment tasks and activities. It was exhibited by all participants except Brad, and most frequently by Andy, Andrea, Borat, Dan, Mark, Reggie, Sam and Wynnie. It was least frequently exhibited by Coral, Leigh, Mary and Wade.

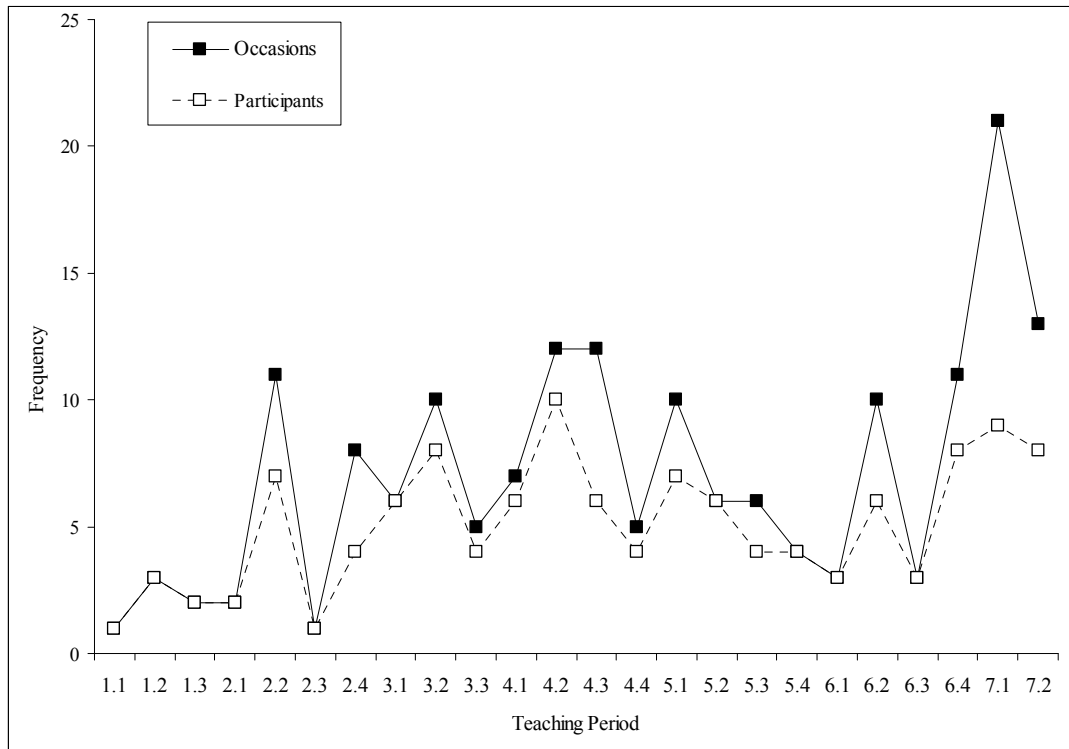

Figure K1. Frequency of participants leaving the room.

Getting Printing

Another pattern of repeated actions was distinguished by students who walked to the front teacher's desk to retrieve printed documents. Reported at Figure K2, is the frequency of this behaviour. It occurred most frequently when students were asked to select and print a set of competencies during the second teaching period of the second day; when students were completing an activity and selecting a competency during the second teaching period on the third day; when students were completing an assessment task in the afternoon of the third day; and on day four when students were writing a letter, creating a flyer, and preparing training plans. This behaviour was exhibited most frequently by Boart, Mark and Wynnie.

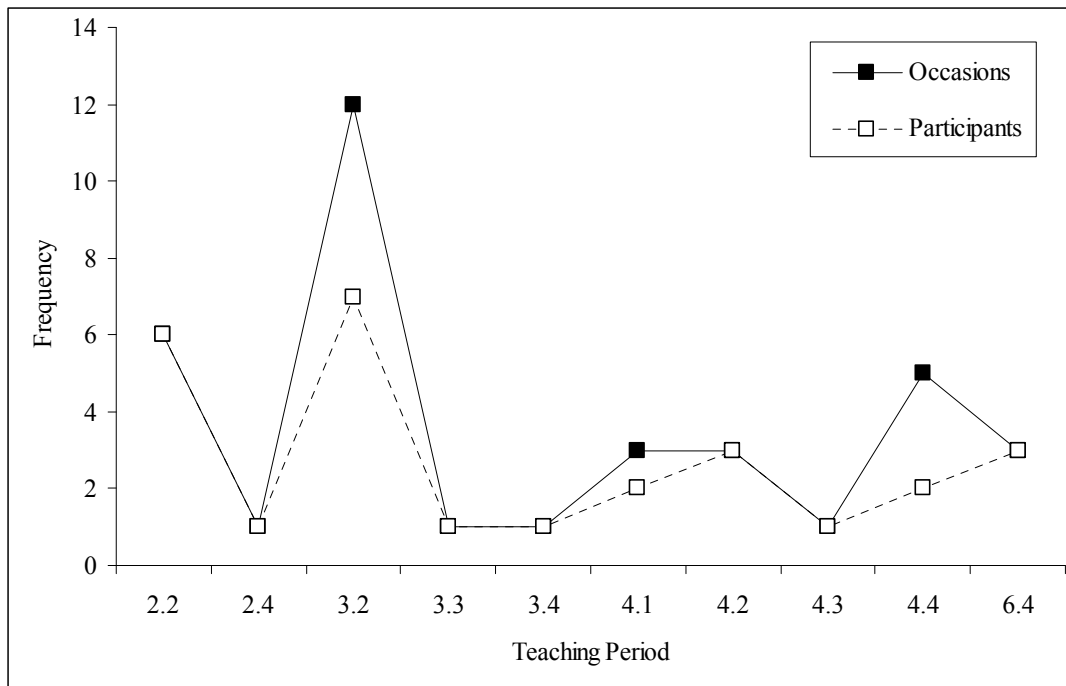

Figure K2. Frequency of participants retrieving printing.

Getting Drinks

A further pattern of repeated actions was distinguished by both teachers and students who got out of their chairs to get drinks. Reported at Figure K3 is the frequency of this behaviour. The first time that Sam told students that they were free to get up and get a drink was during the third teaching period on the fourth day. This behaviour commenced early, increased in frequency and was maintained during the course. This behaviour was exhibited most frequently by Andy, Borat and Mark.

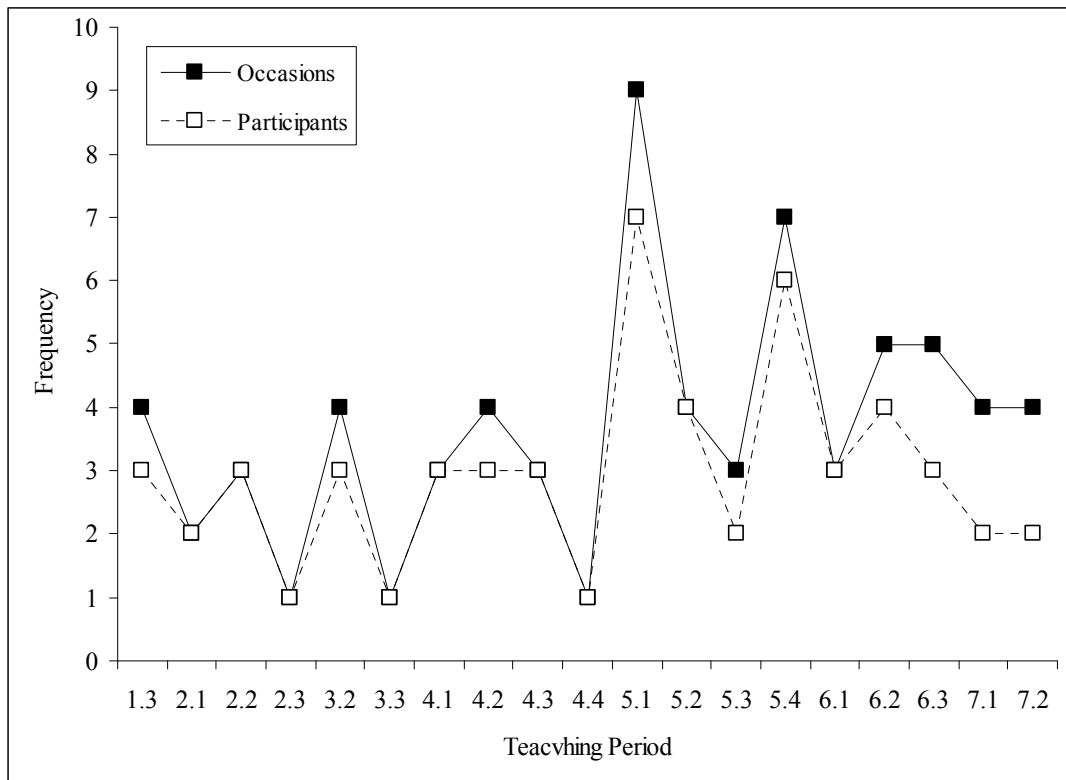

Figure K3. Frequency of participants getting a drink.

Using Mobile Phones

A further pattern of repeated actions was distinguished by people who used mobile phones to send and receive voice and text messages. Reported in Figure K4 is the frequency of this behaviour. Like other repeated actions, it commenced early, increased in frequency and was maintained during the course. There were only five teaching periods when participants did not use their mobile phones. This behaviour was exhibited most frequently by Dan, Mark and Wynn timer. The use of phones during the class was mentioned on only one occasion by the teacher. This occurred during the third teaching period on the fifth day when, after Mark's phone rang, Sam said, "we don't like Mark's phone."

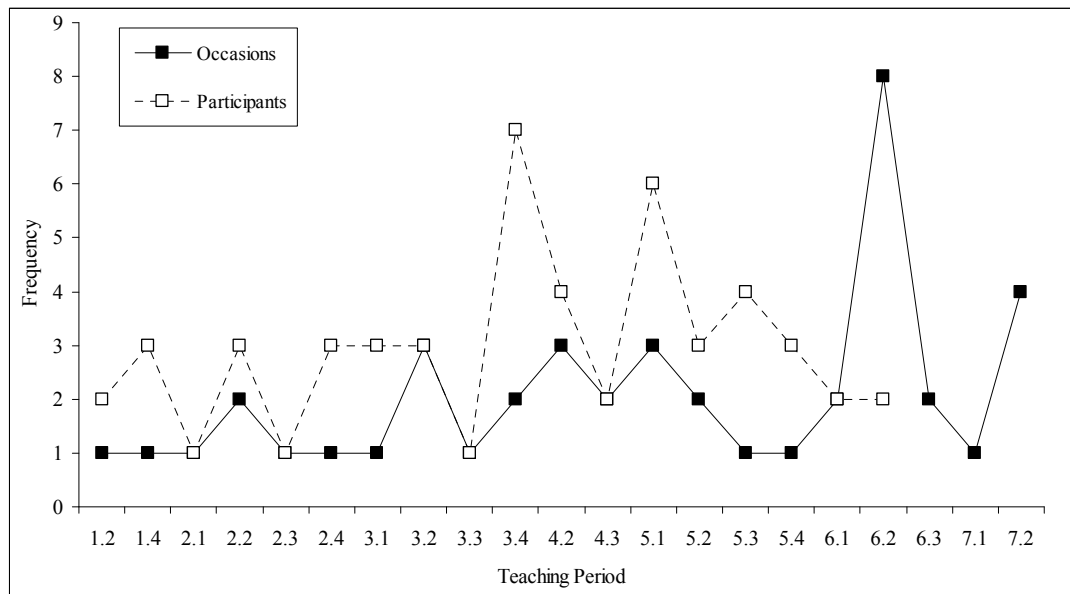

Figure K4. Frequency of participants using mobile phones.

Eating

A further pattern of repeated actions was distinguished by students who ate confectionary and other food during the course. This behaviour started during the second teaching period on the second day with students eating mints that were provided on the coffee table. It increased over the duration of the course to include chocolates, nuts and fruit brought by students and offered to others. This behaviour was exemplified by the following extracts from the running records:

9/02/2007 9:56

Wynn timer passes Danni a mint with her right hand and places it on the desk in front of her. Morgan leans towards Danni as the three of them talk. Danni opens a packet of sweets with both her hands, pulling it apart and takes one. She offers one to Morgan and Wynn timer, and passes the pack to Wynn timer on her right with her right hand. The bag is passed between people down the desks to Andy.

9/02/2007 10:46

Sitting, Sam continues to talk to the group. Adonis wanders under the tables towards Danni. She opens the packet of chocolates and crackles the paper.

Danni and Morgan talk, commenting that Adonis wants the chocolates.

Danni moves her chair back, calling Adonis and coaxing him out.

9/02/2007 11:50

Sam stands up and steps towards Reggie. Standing she talks briefly with her.

Reggie looks up at her and eats a peach as she talks, holding the plastic bag in her right hand, the same hand she is holding the peach in. Sam walks

around the back of the room past Danni. Danni holds some chocolates in

front of her, looking at them, then puts them down. She gets a chocolate

from the pack next her and gets up and leaves the room briefly through the

reception door. She returns with a sheet of paper.

9/02/2007 12:20

Borat asks if he can have a nut from a plastic bag on the desk to Wynn. He

opens the bag and eats one saying they are nice. Sam is sitting down again,

scrolling through the document, and typing as she looks at the computer

screen.

Reggie Pacing

Another pattern of repeated actions was distinguished by Reggie who stood next to her desk for extended periods of up to 60 minutes whilst other students were seated. It was also distinguished by the way she walked around the room for periods of up to 50 minutes. There was only one teaching period when Reggie was present that she did not either stand next to her desk or walk around the room. On one occasion, Reggie returned to the classroom with a box on which she put her laptop.

She then walked around the room and into the teaching space for a period of 50 minutes. During this time several students watched and made comments. This behaviour was exemplified by the following extracts from the running records:

8/02/2007 14:32:47

Reggie asks Alma if she can go back as she was just outside the room. Leigh, Mary and Wade smile as they glance across at Reggie, who has turned around to glance at Heather. Mark's phone rings and Alma continues talking to the group and typing onto her computer. Reggie, with her hands at the back of her hips, walks to the bookcase at the other side of the room, and back. She then paces towards the whiteboard and back again past her desk to the bookcase. She paces back past her desk and back to the whiteboard, and then back to her desk. She glances across at Lady who is lying down asleep at the corner of the coffee table and I hear Andy say, "more than the dog," to Brad. They both snicker quietly. Reggie continues to pace around the room between the bookcase, behind Danni, and her desk, and returns to her desk. Borat pushes his chair out, gets up and leaves through the front reception door.

8/02/2007 14:37:56

Alma still sitting, continues in this fashion as people copy what she has typed into their documents. Reggie, standing and typing at her computer that is rested on the box, squints at the screen, her arms crossed in front of her.

8/02/2007 14:39:09

Sitting, Alma talks and explains key competencies. Reggie starts to pace again. She paces between her desk and the whiteboard, back to her desk and around to the bookcase and back to her desk. Standing, she looks across to

Heather and Lady and clicks her fingers. She then picks up her book from the desk and sits down on her chair, which has been pushed back. Reggie gets out of her chair and paces again behind Leigh, Mary and Wade and pauses at the bookcase before walking back in front of her computer.

8/02/2007 14:46:25

Reggie crosses her arm and paces to the whiteboard again. Borat gives an amusing response to a question to which everyone laughs quietly. Reggie paces back to her desk smiling. Andrea speaks, looking at Alma. Reggie again paces to the whiteboard, this time all the way to the office sliding door, and then returns to her desk. She pauses and paces to the office sliding door and back and her left hand holding the left side of the small of her back, her right hand holding the pouch that she has around her waist. She paces again to the office door, and back again. She paces around behind Wade and the bookcase, pauses and returns to her desk. Standing in front of her computer, she looks down at the open book on the right side of her desk.

Student Voices

Another pattern of behaviours was characterised by aspects of student voices. These aspects of student voices were distinguished by direct and indirect voices.

Direct Voices

Direct voices were characterised by students who directly spoke up and voiced their opinions. On two occasions Coral spoke up on the first day of the course, and Danni spoke up on one occasion on the last day.

Coral Speaks Up

The first event occurred during the second teaching period on the first day. Early in the day, Tanya had told a story about her experiences at university and the difficulty in being measured against personality rather than competency. An hour after the group had returned from the morning break, Sam presented an explanation of the functioning of the vocational education and training sector. Coral spoke up to say that she disagreed with a comment that Sam had made. The following excerpt from the running records provides a detailed account of the event:

6/02/2007 10:58:56

Adonis wanders under the table and gets caught in the main power cord from the ceiling. Sam makes a comment, "Oh no, almost, oh, he's out now." Sam makes a comment in her presentation that University is not client focused, that they have a timetable and if you don't show up it's up to you, you miss the bus. Coral puts her hand up and says, "Excuse me, let's not get into us and them, as a teacher who puts in many hours, there are lecturers who do care about their students." Adonis wanders in the open space and goes to Mark, who pats him and rubs his back. He stops, and Adonis puts his nose up to him. Mark pats him under the chest. Sam apologises, and Mark says that, "it is about putting responsibility on the student." Sam apologises again, and Coral says, "That's okay." Alicia, goes over to Adonis, and checks his collar and sits down again. Coral reaches behind her and gives Adonis a pat. Alicia checks his lead. Adonis lies down with his rump nestled between the legs at the back of Coral's chair.

Coral Speaks Up Again

The second occasion when Coral spoke up and voiced her opinion occurred during the last teaching period on the first day. Immediately before the break Alma had facilitated a brainstorming session with students in an attempt to create a set of agreed ground rules to guide normative behaviour within the group. Ten minutes after participants returned from the break, Alma finished her presentation and told students that there were only four more slides, some questions, and people could go home. The discussion between Alma and students moved towards experience and opinions about the catholic education system. Coral then stated that she believed it was inappropriate to be talking about the topic during the training course. The following excerpt from the running records provides a detailed account of the event:

6/02/2007 16:07:06

Alma asks the group what it was like for people at school. Reggie says it was dictatorial and rote learning. Brad says, "But we still learned to spell, which they don't now." Danni asks if someone can tell their side of the room what rote learning is because they don't know. Alma explains this while standing behind the teacher's desk, and Wynn timerods in realisation. Alma asks Wynn timerods what it was like for her. She listens to Wynn timerods tell her about life at catholic school as she leans with both hands on the back of the chair.

6/02/2007 16:09:40

Lady is lying in the same position, and pants. Coral speaks up that she objects to Alma's opinion about catholic schools and that it is inappropriate in this training room. Mark makes a comment, and Coral restates that she feels it is very inappropriate in this classroom to be talking about this. Danni makes a comment to support Alma, and Reggie says that, "It was one of our

ground rules to respect each other.” Coral says she agrees. Andy asks what the question was, and everyone laughs. Borat tells about how he has seen the learning environment in Czech change. Andy says, “Bruno,” and puts his hands behind his head. Andy explains how computers have changed in mining. Wade comments that our parents would have said exactly the same in their day. Mary, Danni and others nod in agreement. He is making the point that everything changes, and we need to be aware of them. Danni and Sharon and Alma are nodding.

6/02/2007 16:15:22

Alma says, “Let’s carry on then,” and still standing behind the desk, moves onto the next slide, explaining trainers’ responsibilities for outcomes.

Danni Speaks Up

The third event occurred during the first teaching period of the last day of the course, when Alma suggested watching a video. Early in the afternoon of the previous day, Andrea was observed talking with Sam about the video. Sam said they would watch it the following day because students would have some spare time as, “they plan to finish early.” Sam also said that it was strange as she had almost brought the video in that day. Several hours later Sam mentioned to Danni, Morgan and Wynnie that they would be watching the video the following day, and described the movie to Sharon. The following excerpt from the running records provides a detailed account of the event:

15/02/2007 10:15:21

Andrea is patting Buddy, her arm behind her chair. Wynnie gets out of her chair, walks around to Alma and leaning down against her right side asks if

she is going to put on *The Secret* DVD. Typing on her laptop Alma says she is going to put it on in a minute.

15/02/2007 10:22:27

Andrea walks around the back of the room, and leaves the room through the front reception door. Alma says, "Okay let's have a look at the movie," and walks over to the TV screen, picks up a DVD, and says, "I don't mean to be a pain, but I'd rather be studying, and Tanya will be going through that this afternoon." Alma, standing in front of the TV explains that it is not a training module, but someone needs to go through it with them. Danni says that she is in a classroom, and that she "Don't mean to be rude but can you go through it now and then I can go instead of watching a movie." Alma explains that Sam has left us for the day, and Alma doesn't normally teach this. Danni asks how other people feel, Dan says he doesn't mind watching a movie, but would rather do it when Tanya gets back. Andy mentions it's almost time for smoko. They agree to have morning tea now, and go through the material when Tanya is back and then watch the movie. Danni looks around to Morgan and across to Leigh and apologises if no one else agrees.

15/02/2007 10:26:24

Alma says, "Okay, let's have smoko."

Indirect Voices

Indirect voices were characterised by students who indirectly voiced their concerns about having a break, going home, and completing the course. This behaviour was evidenced by the following extracts from the running records:

6/02/2007 15:33

Alma tells the group that afternoon tea is in ten minutes and asks if everyone, “can hang on that long”. There is a general sigh and stretch around the room.

7/02/2007 12:31

Sam continues, she is settling down at her laptop. Andy attempts to interrupt her, but she says, “No, not yet, we’re getting to that,” pointing her finger and wagging it several times at Andy. He replies, “I’m hungry I want to go to lunch.” People laugh louder.

9/02/2007 12:37

“Is it lunchtime yet?” asks Wynn timer. Morgan talks with Danni about the training methods they are using.

9/02/2007 15:03

Standing against the whiteboard, Sam explains that four are required to be designed but only one presented. Andy says he wants to do this at home as he can’t do it here, and asks for a USB. Sam picks up a USB and takes it to Andy.

9/02/2007 15:13

“Want to go home,” says Wynn timer. Two boys walk past the outside window. Wynn timer says, “That’s them two boys that played a trick on me this morning.” Sam walks around the room behind Dan says they are Tanya’s twin sons.

9/02/2007 16:48

As Sharon passes Sam, she asks if they are allowed to do it at home and says, “Thank God,” and returns to her chair.

Sam, standing in front of her desk, asks what she was going to say next, and Andy says, “smoko.” Sam continues talking.

15/02/2007 12:01

Tanya looks at Andy who says, “It is a long time sitting down doing this course.” She says, “It is better than TAFE where it is over six months and you have to do all the assignments at home.”

Indirect voices were also characterised by students who voiced their concerns about participation in classroom exercises and assessments. For example, on two occasions when asked to select an activity that related to what students would be presenting the following week, Reggie said that she would not be participating. On another occasion Morgan said that she did not need to do an exercise that she had previously completed. On another occasion Andy said that he would not be doing any more writing. These occasions were evidenced by the following extracts from the running records:

8/02/2007 11:08

Reggie says she won't be here next week, when Alma says that the exercise can be for something that people are training in next week. Standing in front of the computer, Alma asks people to write down some things to consider in their training course. Borat adjusts his chair. Wynnie sits up in her chair.

People start to write down their notes, though Morgan is leaning back in her chair, scratching her left forearm with the pen she has in her left hand.

Reggie asks for clarification. Alma asks people to break into pairs. Wynnie pats Borat on the back a couple of times gently and says, “I'm with you buddy.” Morgan puts her hand up saying she doesn't have to do this

assessment as she has a certificate of attainment. Alma says she could have had a sleep in today then.

8/02/2007 11:56

Sitting at the teacher's desk and looking at her computer screen, Alma explains they are going to look at the next section. She asks the group if they know what unit they are going to train in. Reggie says she doesn't cause she won't be doing it next week.

15/02/2007 9:56

Andy says he's not doing any more of, "That writing. I want to do the computer." He gets out of his chair and leaves through the reception door, closing it behind him.

Indirect voices were also characterised by students who indirectly voiced their concerns about their physical and emotional comfort. For example, shortly before the lunch break on the first day, Coral leaned over and asked Alicia if she could wrap Adonis around her neck. Towards the end of the first day, Brad asked Alma if it was getting hot in the room, and shortly afterwards Mary commented to Leigh that she felt it was hot. Two days later, Wynnne said that she felt cold and Danni said that she would bring a blanket in the next day.

Another example of students who voiced their concerns about their physical and emotional comfort occurred during the third teaching period on the first day, Coral said that she thought there should be a, "ground rule that we get to stand up for five minutes every hour or so," soon after which Andrea turned to Mark and quietly told him that the chair had been pinning in her back.

Another example occurred on the second teaching period of the second day when Sam told Andy that she would be working through his competency and that he

had, “one up on others.” Wade then commented to Mary and Leigh that Andy was the, “teacher’s pet.” A further example occurred during the third teaching period on the third day when Sharon got up out of her seat in an exaggerated and deliberate manner, walked towards Heather and picked up a dining chair that she put next to her own seat. She picked up her folders, put them on the chair and sat down. Another example occurred on the last day of the course when Sharon got out of her chair and said, “This is a waste of time.” Soon after Andy said that the course had, “blown him out of the water,” but that they were, “back in the canoe again.”

Teacher Voices

The pattern of student voices was contrasted with aspects of teacher voices that were characterised by setting expectations, attribution, authority, self-efficacy, speaking of self and body language.

Setting Expectations

The pattern of teacher voices was distinguished by the nine occasions when the teachers said that students either could finish early once they had completed the set tasks, or implied that students needed to complete the lesson before breaking. The only occasion the class finished early was day three when the class ended at 4:15 pm. However Alma said that students needed to complete an exercise as homework. This pattern was evidenced by the following extracts from the running records:

6/02/2007 16:01

Everyone takes their seats and Alma, standing to the left of the table explains that there are only 4 more slides, some questions and then people can go home. [The class ended at 5:00 pm.]

8/02/2007 9:01

As they set up, Alma introduces herself, and says, “Today is fairly light on and we might get an early mark.” [The class ended at 4:15 pm.]

8/02/2007 11:05

Wynn timer and Borat give a quiet, “Yeh,” at the promise of being able to go to an early lunch if they get the next exercises completed early. [The class broke for lunch at 1:00 pm.]

9/02/2007 16:06

Wynn timer asks if they can go home and Sam says they can if they get through this [exercise]. [The class ended at 5:00 pm.]

13/02/2007 15:04

There is a brief discussion about Sam’s singing and Wynn timer asks if they can go home now. Andrea makes a comment about coming in Thursday. Borat suggests they go to an early break, and then what time they finish on Thursday. Sam, leaning her hands on the back of her chair, explains what they will be doing over the next two days and that they may finish early on Thursday afternoon. Andrea, leaning back in her chair holding her phone in front of her, asks if they are having a “fiver.” Sam explains that she is a segment person not a time person. [The class ended at 5:00 pm.]

Attribution

The pattern of teacher voices was also distinguished by the nine occasions when teachers commented about the perceived level of difficulty of the lesson content and the capabilities of students by saying, “today is going to be fairly light on,” or that, “it gets confusing,” or that, “you’re doing fine.” This often contrasted with observed behaviours. For example, on one occasion Sam said that students

who were drawing a diagram were “doing fine,” yet continued to correct them and said she would, “be kind,” and redraw it for them. The pattern of attribution was evidenced by the following extracts from the running records:

7/02/2007 9:17

Sam walks past the front screen to the whiteboard and says she is going to be kind and redraw the diagram from yesterday. As she redraws the diagram on the whiteboard, she explains the structure diagram of the VET system. Many people are watching her draw. She pauses, and says, “it gets confusing,” and laughs, and then continues to draw. “No that’s not right,” she says and rubs out part of the diagram saying, “don’t write that down.” She continues drawing, pauses again and moves to the front desk looking down at her notes and says, “What have I left out.” She then walks back to the whiteboard and adds to her drawing. She walks back to the front desk and says, “Does that make it any easier,” and laughs lightly. She has the whiteboard marker in her hand as she talks. She waves her hands and then places the cap on the marker and puts it on the board. She says, “but you did very well, I think every time I draw the diagram I draw it differently.” She takes a sip of water from the cup on her desk.

7/02/2007 14:51

Sam, still standing skips over a couple of slides and says that people can, “work in pairs helping each other if they want to.” Borat stretches his arms above his head and sighs. Sam says, “Oh gheez, you’re going to have fun Andy.” She sits down and opens another document.

7/02/2007 15:21

Dan leans back in his chair and crosses his arms behind his neck. Sam continues to talk and Mark asks a question. Sam, still sitting at her desk, asks how people are going and says, “Come on, it’s pretty easy.” She continues typing into the document on her laptop as people work on their laptops.

9/02/2007 14:53

Andy gets up out of his chair and leaves the room through the reception door, announcing that he needs to go to the toilet. Sam walks over to Brad holding a piece of paper and pauses for a few moment, leaning over as she talks to him. She walks around the open space behind Dan, and then Mary, and asks if anyone needs help. She says that they have counselors, “if people need help after this week,” laughing as she does so.

Authority

Authority was implied by the way the teachers expressed the teacher—student hierarchy. For example, during her introduction on the first day, Tanya pointed towards Sam and asked, “Who governs teaching here, Sam?” Later that day, Alma used body language to emphasise the teacher—student hierarchy. This was evidenced in the following extracts from the running records:

6/02/2007 14:16

“As a training provider,” she taps her chest with the fingertips of both hands several times quickly. Andy is looking downwards, towards the laptop screen. Brad is looking down at his papers. Andy looks up towards Alma briefly.

6/02/2007 14:23

Andy is looking towards Alma, who continues her presentation. When she says, “us, our RTO,” she pats her chest with her fingers again.

6/02/2007 15:24

Alma introduces the next activity, reading from the laptop. When she says, “you are all students,” she points all ten fingers at the group. She asks what rights students have. Dan and Reggie make a couple of responses. Borat offers an answer and Alma says, “yes,” nodding her head, sitting at her laptop.

The teacher—student hierarchy was also implied by Sam during the last teaching period on the fourth day, when she said to Andy that, “every class has got one and you’re the clown.” It was also implied by the way Sam left the room when Borat began his presentation. This was evidenced by the following extracts from the running records:

13/02/2007 12:12

Sam has gone out the exit door, saying she knows where they have gone. She reaches down into her bag to get a cigarette and she leaves through the exit door, saying she’ll keep an eye out for when they return and that it is best to wait for them so they don’t interrupt. Borat is standing in the front of the desk, leaning over as he sets up his computer. Andy briefly re-enters the room saying he has forgotten his pills and leaves again. Sam looks in through the outside window. A moment later I see Andy walking in the car park with his car keys in his hand. He looks over to Sam who walks up to him, and they stand there for a few minutes talking. Mark re-enters the room and Andrea is typing into PowerPoint on her laptop screen.

Authority was also implied by Tanya who said to students, “you know I used to be a school teacher don’t you,” and by Sam who said that Tanya liked to receive a rating of five on her feedback sheets and became upset if she received a lower

rating. It was also implied by Sam who said that students could write their own comments on their assessment sheets, such as “Well done, competent,” and that Tanya would read and sign them. A further example was when Andy commented that it was a long time sitting down doing the course, and Tanya said that, “It is better than TAFE where it is over six months and you have to do all the assignments at home.” Authority was also implied by Tanya who, at the start of last teaching period on the second day, said to Sam that there was a, “quicker way of doing the assessment,” and subsequently assumed the role of teacher for the remainder of the lesson. Sam briefly assisted with printing before taking a seat at the back of the room.

Air Conditioner

Authority was also implied by the way Alma appeared to position her needs above those of her students when she controlled the temperature within the room. This contrasted with students’ comments and the dog who panted. At the start of the course the temperature in the room was warm and became cooler towards the end of the second teaching period. This was evidenced by Coral, who asked Alicia if she could wrap Adonis around her neck. Towards the end of the first day, Alma increased the thermostat, which contrasted with students’ comments about the increasing temperature and the dog panting. This was evidenced by the following extracts from the running records:

6/02/2007 15:39

Alma goes out the office door and returns with the remote control for the air conditioning. She moves inside the room again, points the remote at the air conditioner and adjusts the setting. It lets off an audible beep and she leaves the room out the office door, which she leaves slid half open.

6/02/2007 16:01

Lady lies down behind Mark's chair, in front of Heather, panting, head towards me.

6/02/2007 16:15

Lady walks back to the exit door, and lies down again, still panting slightly. Alma reads from her laptop. It is getting warmer in here after Alma adjusted it.

6/02/2007 16:17

Brad asks if it is getting hot in here. Alma says that she turned the air up. Brad says, "it's okay, but I didn't know if it was just me."

6/02/2007 16:47

Still sitting at her desk, Alma continues. She offers her own suggestions, typing them into the assessment sheet for people to copy. Mary makes a comment to Leigh that it is very hot. Johannes gets up, walks across the front of the room to the coffee table where the remote is and picks it up. Alma, sitting at her desk, tells him he has to use the one in the office, waving her hands behind her at the office door. She comments that, "It was too cold before, now it's too hot." Johannes uses the remote control to turn the air con down to 23 degrees and puts the remote on my desk. He walks around the back of the room and takes his seat back at his computer.

Chinese Lunch

Authority was further implied by the way Alma appeared to position her needs above those of her students when she ordered lunch whilst presenting, and by the way Tanya entered the room and removed a chair on which to sit during lunch. This was evidenced by the following extract from the running records:

8/02/2007 12:04:32 PM

Sally opens the sliding office door briefly to pass a note to Alma who turns behind her to retrieve it. She talks briefly to Sally and says, "Oh no," and then, "Can I have the list please?" She passes the note back to Sally who closes the sliding door. Alma asks if people have downloaded their training packages, and a few people say they have and they continue working on their computers. Morgan has opened hers and is looking at it on the computer. Sally re-opens the sliding office door and hands Alma a brochure from *Yummy Noodle*. Alma looks through it briefly before handing and hands back to Sally. She says something to her, and Sally closes the office sliding door.

8/02/2007 12:37:04 PM

The front reception door opens and Tanya enters, pausing briefly at the doorway and apologises. Alma says, "everyone say hello to Tanya." Tanya walks in the room, says sorry, and that she is just looking for a chair. She walks up the side to the back of the room and picks up a chair with both hands and walks back, squeezing between the chairs as she leaves, smiling as she passes me.

8/02/2007 12:48:26 PM

As Heather leaves, she asks me what time for tomorrow. I walk out with her and Tanya and a few of her staff are sitting at a desk directly outside the door, eating Chinese food. I take a short break and walk back into the room.

Managing Student Behaviour

Authority was further characterised by the way Sam attempted to manage the behaviour of students on five occasions, by explicitly and implicitly directing

students to stop talking. This was evidenced by the following extracts from the running records:

9/02/2007 14:16

Morgan, Danni and Wynn timer whisper something. Sam lifts her head from leaning over the computer and says, "Were you talking again?" They say they were not.

13/02/2007 10:01

Sam is standing at the front desk, and leaning with both hands on the back of the chair. She talks, giving feedback on Leigh's session. People look at their laptops, typing in information. Sam makes the comment that, "Maybe the assessment tasks could have been better explained if they weren't all talking."

13/02/2007 11:32

Sam asks for more feedback. Mark, turned in his chair, talks, looks at Sam. Mary makes a comment. Andrea, looking first at Danni, says that she could have gone slower because it was foreign to her. Andy and Borat are looking down. Wynn timer is talking across the desk to Leigh and Mary. Sam taps her shoulder and says, "Unless you are giving feedback to Debbie, zip it."

13/02/2007 15:00

Standing and leaning on the desk with both her hands, Sam asks if there is any feedback. Danni says she can do with a microphone. Sam says she needs to talk up particularly with this noisy group.

14/02/2007 9:38

Wynn timer says that she is next and gets out of her chair with a folder and USB in her left hand and bag in her right. She walks around the front of the room,

drops her bag to the left of the teacher's desk and leans over the laptop. Sam walks around the back of the room past Danni, and says that she'll, "sit next to the quiet one," and sits briefly in Leigh's chair.

14/02/2007 16:24

Sam re-enters through the sliding office door, sits back down at her desk and says, "with Assessment 3j you will need to fill it out." She says that she will type it up on the screen as she has to do it for Andy. She says, "Hey guys, listening please," as Morgan, Danni and Wynnie are talking. They stop talking.

Authority was also distinguished by the way Sam, during the first teaching period on the sixth day, referred to Wynnie as, "a naughty girl."

Self-Efficacy

The pattern of teacher voices was also characterised by the 24 occasions when the teachers commented about their own abilities, behaviour, appearance and language skills, and when Sam self-corrected her mistakes. This was evidenced by the following extracts from the running records.

7/02/2007 9:17

As she redraws the diagram on the whiteboard, she explains the structure diagram of the VET system. Many people are watching her draw. She pauses, and says, "it gets confusing," and laughs, and then continues to draw. "No that's not right," she says and rubs out part of the diagram saying, "don't write that down." She continues drawing, pauses again and moves to the front desk looking down at her notes and says, "What have I left out." She then walks back to the whiteboard and adds to her drawing. She walks back to the front desk and says, "Does that make it any easier," and laughs

lightly. She has the whiteboard marker in her hand as she talks. She waves her hands and then places the cap on the marker and puts it on the board. She says, “but you did very well, I think every time I draw the diagram I draw it differently.”

7/02/2007 14:26

Sam mentions that she is really uncomfortable when doing this cause she is a “shorty” and has difficulty looking over the computer.

7/02/2007 14:36

Andy looks blankly into space across the desks. Borat tilts his head backwards and looks up briefly at the ceiling, eyes slightly closed. Sam lifts her leg towards the desk, and says she shouldn’t do that, and that she is not at home.

7/02/2007 15:26

Sam says she always gets a positive response from dogs so she, “must be a bitch.”

8/02/2007 10:20

The reception door opens again and Reggie enters the room and stands just behind Andy, watching the screen. Alma asks if anyone can teach her to invert her triangles. Borat puts his head down on the table briefly, nodding and bouncing his head. Wynn timerches over and pats his back a couple of times with her right hand.

8/02/2007 14:39

Laughing and smiling, Alma asks who remembers what the key competencies are. She throws both her hands in the air above and slightly behind her head and says that she doesn’t even remember them.

9/02/2007 9:50

“So Wynnie,” says Sam as she looks up at Wynnie after she has finished typing. Sam looks back to her computer and scrolls up and down the document, talks quietly to herself, and says, “You know what? After all that I think I’ve done the wrong thing here. I think this memo is supposed to be the management with a breakdown of costs.” She smiles, her hands clasped in prayer in front of her. “Sam!” exclaims Wynnie looking at Sam.

9/02/2007 13:54

During the break, Sam tells some of the group in a discussion at the lunch table that she is manic-depressive and is on medication for life, and has high and low days.

9/02/2007 14:30

Sam says there are three types of evaluation, formative and summative. She asks students what the other one is, and criticises herself that as a trainer she should know.

9/02/2007 14:50

When Sam gets her glasses out and puts them on she says she really looks like a school marm. Andy says that she looks like Morag from the television soap opera *Home and Away*. There is some laughter.

Speaking of Self

The pattern of teacher voices was also characterised by the occasions Sam spoke of herself, described her professional commitments outside the classroom, and recounted stories from her personal and professional life. For example, on six occasions during the course, Sam asked students if they had experienced a training audit, and spoke about the one that she was to be involved with. She explained that

because of a change in arrangements, she would not be teaching the class on the last day of the course. On one occasion Sam excused herself and she said she was, “thinking financial as I’m about go through an audit.” She said that she would be, “more relaxed after Friday,” once the audit had been completed. During the last teaching period on the fifth day Wynnie asked Sam why Tanya’s name was on the assessment sheets. Sam explained that Tanya used to run the course. Sam covered her face when she said that she (Sam) would no longer be teaching the course.

Sam recounted personal stories about herself on four occasions during the course. For example, Sam told students the story of her son singing the song *True Blue* when he was four; recounted the story of her singing career that had ended because of a medical condition; retold the story of a trainer who stuttered as they spoke; and recalled the story of an inappropriate meeting at a hotel room with out-of-town training assessor. The speaking of self characteristic of the pattern of teacher voices contrasts with Alma’s presentation on the Johari Window¹⁹ and the discussion that followed about how best to encourage others to reveal undisclosed personal information.

Teacher Body language

The pattern of teacher voices was also characterised the aspects of their body language. For example, the teachers frequently sat at the front desk and looked at the computer screen with their elbow rested on the desk and chin cupped in their left

¹⁹ The Johari Window is a communications model designed to help people understand how their personal communication with others helps build trust. It seeks to understand what a person reveals or withholds about themselves, and what is known or hidden about others (Luft, 1984).

hand. They continued to look at the computer screen when they spoke to students and answered their questions. On other occasions the teachers stood behind the front desk and leaned forward, and rested their hands against the back of the chair in front of them. When the teachers stood, they frequently gesticulated with their hands by waving them in the air in front of them. They occasionally stood with their arms folded across their chest for brief periods, and pointed and wagged their finger at students. Alma's exaggerated body language included drawing shapes and quotation marks in the air to emphasise the words as she spoke. This was evidenced by the following extracts from the running records:

6/02/2007 14:16

Everyone is looking forward at Alma. She moves the slides forward and explains why access and equity is important, gesticulating with her hands and arms. She uses the word *whole*, and draws a big globe in the air, starting at the top. "As a training provider," she taps her chest with the fingertips of both hands several times quickly.

6/02/2007 15:04

Alma adds additional information, reading from notes on her desk, tapping her fingers with the pen at each point. When she says, "this group of things," she draws a circle in the air above her notes.

6/02/2007 15:26

Alma continues her presentation. When she says, "it's not alright for me to leave your papers in the car for someone to look through," she cups her fingers around her eyes making eye-glasses.

6/02/2007 16:01

She stands to the side of the desk, next to the screen, and explains the diagram about top-down, bottom-up learning. She points to the screen and uses her hands in expression. When she says, “building on more and more,” she rolls her hands over and over. When she says, “whole thing,” she draws a large circle in front of her. When she says, “balance,” she holds her hands like a scale and moves each one up and down in sequence.

On several occasions Alma adjusted her clothing, put her hands in her pockets, chewed her fingernails, looked down in her lap as she spoke to students, leaned back in her chair, raised her arms above her head and brushed her hair with her hands, pinched the side of her face, rested her hand on her hip, and when as she stood next to and spoke with a student, rested her foot on the rung of their chair. This characteristic contrasted with the brief discussion that Sam had with students regarding body language when presenting, during which she suggested that people videotape themselves to identify bad habits.

Student Engagement

A further pattern of behaviours was characterised by aspects of student engagement. These aspects were: distraction and student body language.

Distraction

Distraction was characterised by the way students used computers to play games, look up web sites and access email; the way they read newspapers; and the way they looked outside the classroom or towards the ceiling.

Computers

The use of computers as a characteristic of distraction was distinguished by eight students, Andrea, Borat, Dan, Danni, Mark, Morgan, Sharon and Wynnie who

used email, played games, and looked up web sites such as, *eTrade*, *Australian Stock Exchange*, *Seek*, *Career One*, *Yahoo Email*, *Queensland Government* and *Bureau of Meteorology*. This was most noticeable on the afternoon of the sixth day and the morning of the last day of the course. It was exemplified by the following extracts from the running records:

14/02/2007 12:46

Sam talks about a truck being left without fuel, and Andy says that is worth a carton as Andrea laughs. People are writing on the paper in front of them. Mark talks briefly, hands in both pockets. He looks at Sam, standing slightly to the left of the screen, occasionally casting shadows on the screen. Danni takes her glasses off and looks at her laptop on which is displayed the *eTrade* web site, and she looks at the screen. Andrea looks at Mark as she asks a question, and there is a little laughter. Mark talks briefly. "Where is it," Danni asks leaning slightly to Morgan who says she doesn't know, and shakes her head briefly. Danni continues scrolling through the web site, reading the screen and holding her head in her left hand. Wynnie is typing as she reads the screen in front of her that displays the *MSN* web site. Morgan has a *Google* search page displayed. Wynnie briefly has a *Live* search page displayed, and clicks on a link to display the *Career One* site. Andy, turned towards Mark is speaking. Sam talks, and Andrea laughs as she leans across pointing at Andy. Wynnie scrolls and searches through the *Career One* site. Sam says they have lunch in ten minutes.

14/02/2007 13:08

Danni is continuing to look at jobs and then switches to the *Australian Stock Exchange* site. Heather and Andrea talk to each other.

Newspapers

The use of newspapers as a characteristic of distraction was distinguished by the way Danni, Morgan and Wynnie read newspapers. This was evidenced by the following extracts from the running records:

15/02/2007 10:04

Wynnie walks around the front of the room to the coffee table and pours a drink. Danni holds up a newspaper, and says, "How can you look like that." Sharon looks across and comments briefly. Both laugh as Sharon gets out of her chair and leaves the room through the reception door and leaves it open. Wynnie holding a cup walks back around and sits back in her seat. Sharon walks back in, closes the door behind her, holds up several sheets of paper, and looks around the room. She asks, "Is this anyone's printing?" Leigh gets out of her desk and Sharon hands her a piece of paper. Danni is reading the newspaper in front of her, turning the pages. Morgan looks down at the paper also, occasionally pointing to the page.

15/02/2007 10:08

Danni turns the pages of the newspaper. Wynnie types on her laptop, occasionally looking over at the newspaper and says, "Wow, huh?" Morgan looks down to her right as Danni reads the paper.

15/02/2007 10:12

Morgan looks around the room. Wynnie turns to Borat asking him when he is going home. She stands up, and briefly holds up the newspaper. She reaches for her bag on the desk behind her and talks to Borat about speeding tickets and her cousin.

Looking Out and Away

Looking out and away as a characteristic of distraction was distinguished by the way students looked out through the rear window or looked away and up towards the ceiling. This was evidenced by the following extracts from the running records:

6/02/2007 11:33

Most people are looking towards the front. Sam continues her presentation. Danni is looking away up at the ceiling, across the desk, through the window.

6/02/2007 11:40

As it starts to rain, Sharon and Dan and a couple of others briefly look out the window. Reggie moves slightly and leans against the corner of the window with her hands crossed behind her back. Mark asks a question, "Aren't they referring to that as VET in school?" Sam says, "Yes." Reggie crosses her arms in front of her and turns to her right and looks out the window.

7/02/2007 11:17

Sam sits down again, and continues reading and explaining the document from her laptop. Most people are looking forward at the screen and Sam, or at the document on their own laptop screens. Wade turns his head to the left and looks out the exit window through the small gap in the curtain at the rain coming down.

7/02/2007 14:36

Leaning against the desk with her hands, Sam looks down at her laptop and explains the bullet points displayed on the screen. Borat looks briefly into

space across the desks. Andy looks blankly into space across the desks.

Borat tilts his head backwards and looks up briefly at the ceiling, eyes slightly closed.

13/02/2007 11:40

Andy starts to talk. Morgan laughs silently and holds her chin in her right hand. As people move outside the classroom window, she frequently looks around, glances out the window at them. Leigh turns and glances briefly outside.

Student Body Language

Student body language was characterised by the way students stretched and yawned, sang and danced and by general patterns of body language. For example, during 13 of the 26 teaching periods during both the morning and afternoon lessons, students stretched their arms above their heads, sighed and yawned. On several occasions during the course, Andrea, Danni and Wynn timer sang and danced whilst seated in their chairs. The body language of students was further characterised by students who rested their head against their hands or cupped their chins in their hands, leaned their elbows on the tables, closed their eyes, leaned back in their chair, and rested their arms over the backs of the chairs. Occasionally they balanced the chairs on two legs, raised their arms and crossed their hands behind or on top of their heads, crossed their arms against their chests, covered their mouths with their hands as they spoke, slouched in their chairs, and rubbed and covered their eyes with their hands. On one occasion during the afternoon of the first day, Andy pulled his cap down to cover his eyes. During the first teaching period on the third day Borat rested his head on the desk in front of him. On the fifth day of the course

Morgan took off her shoes. This pattern of behaviours was evidenced by the following extracts from the running records:

8/02/2007 9:43

Borat readjusts his seating, pulling himself up in the chair and leans forward, his elbows on his thighs, hands in front of him and yawns. Wade, his arm across his stomach and other hand to chin, yawns also.

8/02/2007 10:15

Wade leans back in his chair balancing on two legs. Morgan puts her chin in her hand again, leaning on the desk.

8/02/2007 10:20

Alma asks if anyone can teach her to invert her triangles. Borat puts his head down on the table briefly, nodding and bouncing his head. Wynnie reaches over and pats his back a couple of times with her right hand.

8/02/2007 10:26

The reception door opens and Sally enters, walks around the front behind Alma with a platter of food and puts it on the table before leaving through the same door. A few people shuffle in their chair. Borat stretches his arms above his head.

8/02/2007 11:02

Alma continues talking to the group who are looking at her. Wynnie is slouched down in the seat, her rump close to the front of the seat. Borat yawns.

8/02/2007 11:08

Andrea yawns, reaches her right arm behind her back, and stretches and leans back in her chair briefly.

8/02/2007 11:50

Brad remains turned towards Andy who continues talking with him. Borat gets out of his chair and takes a sheet of paper from the printer. Wade leans back and stretches his arms above his head.

8/02/2007 12:00

Sitting at the teacher's desk, Alma continues talking as she holds the paper up. Andrea yawns.

9/02/2007 9:16

Wynn timer starts singing quietly. There is more chatter and discussion. Sam, Sharon and Borat are standing in front of the printer, opening the cartridge. Reggie has walked over to Jonathan saying she has a problem printing. They walk back to her computer looking at the screen. Wynn timer continues singing and Debbie is quietly joining in trying to recognise the song when Andrea looks over and sings also. "That's it, you'd know," says Wynn timer across to Andrea, looking over to her.

9/02/2007 16:04

Sam returns to the front of the room. Andrea and Wynn timer discuss who has a copy of a certain page. Andrea says she has and both Andrea and Wynn timer stand up as Andrea hands Wynn timer the papers over the middle of the desks. Wynn timer sings Andrea's name.

13/02/2007 14:57

Sam gets out of Mary's chair and walks to the front of the room, papers in her hand, and hands a piece of papers to her. Danni and Wynn timer start singing a song. Morgan says, "it's not me it's them." Mary gets out of her chair and walks back through the open space to her chair.

14/02/2007 10:52

Sam's phone rings playing the *Sesame Street* song. Sam gets up and walks to the front of the room. She reaches down to her bag and picks up her phone.

Wynnies sing-songs the tune playing on Sam's phone.

Additional Observations

As well as the patterns of teacher and student behaviours, additional observations included the use of the printer, the use the overhead display and whiteboard, and the use of the student learning guides.

Printer

The use of the printer was characterised by technical problems experienced by students when they attempted to print documents. These problems included not being able to display the print dialogue box and documents being routed to a printer outside the classroom, rather than the one located in the classroom. On several occasions Johannes provided assistance to students in resolving these problems, and on one occasion Mark sought the assistance of Tanya's sons. On several occasions, students expressed frustration caused by these problems, which started during the first teaching period on the first day and persisted until the end of the last teaching period on the sixth day of the course.

Overhead Display

The use of the overhead display was characterised by the way the teacher used a data projector to display a projected image of the teachers' computer screen on the front wall. During several presentation lessons, the teacher displayed an electronic slide presentation. However, for the majority of the course the teachers displayed a word processing document as they completed the exercises and assessment activities, from which students copied the answers onto their own

computers. The small font size used rendered the text more difficult to read further away from the screen, despite the large size of the displayed image. This was evidenced by Reggie who frequently squinted and walked up to the front of the room to read the projected display. On several occasions during the last three days of the course, a problem with the projector caused the displayed image to become partially obscured when the computer's mouse was knocked or moved. This made it difficult for students to read the display and was evidenced by the following extracts from the running records:

13/02/2007 10:01

Sam walks around behind Dan and then back to her desk to the left of Sharon. She picks up a piece of paper before sitting down again. She looks at the laptop screen and asks why the data projector is not showing the entire image. Sam says she'll ask Johannes to look at it. She walks around the front of the room, opens the door and stands in the doorway talking out.

13/02/2007 10:11

Sharon continues her presentation. Sam explains that she must move the mouse slowly to align the screen image correctly. Mark and Andrea are both turned in their chairs towards the front.

13/02/2007 14:37

Sam walks around the room, puts a cup back on the coffee desk, and stands in front of Mary's seat, and talks. She walks around the open space back to the front desk and tells Mary that she needs to adjust the mouse when using the data projector.

15/02/2007 11:39

Tanya talks as she leans over scrolling through the document and stands back. Andrea says, "Can you just move the mouse to the left so we can see the whole screen." Tanya leans over the laptop, and attempts a few times to move the projected screen into view. Alma walks behind her and says that she has, "missed it. Just move the cursor." She sits down in the chair in front of the television, leaning her left arm on the back of the chair

Whiteboard

The use of the whiteboard was characterised by the way some students experienced difficulty reading the teachers' writing. It was also characterised by the way on the last day of the course Borat tripped on the legs of the whiteboard when it was placed next to the door. These characteristics were evidenced by the following extracts from the running records:

7/02/2007 16:51

Morgan asks what the orange writing is, as she can't read it. Tanya gets up and steps towards the whiteboard, reading it out. She then rubs out the orange writing and rewrites it in blue.

8/02/2007 14:49

Alma continues discussion with the group, typing into the document the ratings of the key competencies of the checklist. Reggie paces down to the whiteboard, and turns to face the whiteboard on the wall. She pauses to read from it with her arms crossed on her stomach in front of her.

15/02/2007 9:31

Borat walks around the front of the room, and trips. Andy and Wynnie make comments that he is in a bad way this morning. Borat walks to the coffee

machine, and takes out a few trays, puts the jug on one and with a tray in either hand, kicks open the office sliding door and leaves.

15/02/2007 11:36

Borat gets up and walks behind Brad. He trips at the whiteboard and Andrea says, "That's the second time he's done that." Borat goes to the coffee table pours a drink of water, walks behind Tanya and Alma and sits down.

15/02/2007 11:43

Andy asks Tanya quietly if he can, "see that girl out there." He holds several sheets of paper, gets out of his chair, turns and leaves through the reception door, closing it behind him. Tanya looks down at the floor where Andy walks and says she "might have to do something about the whiteboard."

Student Learning Guides

The use of the student learning guides was characterised by the way the teachers referred to information and the way students had difficulty locating it. It was also characterised by the way students dropped them on the floor beside their chair, thereby making loud thudding noises. These characteristics were evidenced by the following extracts from the running records:

6/02/2007 9:54

Reggie comes back into the room through the front door near Tanya and goes to her chair and sits down. Tanya walks around the room behind Sharon as people start using their computer. A few people drop their thick workbooks and papers on the floor next to or behind them with a thud. Leigh does this and Adonis wakes up and moves to a spot still in front of Alicia but behind Wade and Mary.

9/02/2007 12:26

Sam stands up asking, "Have you got the idea? It is in your book." She looks around her desk and walks over to Dan and standing behind and between Mark and Dan, opens a book and starts turning the pages. She tells people what page it is on before closing the book. She reaches for another book in front of Dan, and places it on the desk in front of her and stands up, as she talks. She leans over again, opens the second book lying on the table, and thumbs through the pages.

9/02/2007 12:27

Borat gets up and walks to the printer. He picks up some paper and returns to his chair. Danni looks across the desks and asks Sam a question. After answering Danni, Sam turns the pages in the book, and says, "It must all be in the first book," and closes it. She reaches to place the book back in front of Dan. Dan reaches for the first book and hands it to Sam who opens it on the desk in front of here and turns the pages.

9/02/2007 12:30

"Delivery options," says Sam and stands up, cradling the book in her right hand. She continues turning the pages, occasionally reading the headings out loud. "Okay, on page 65," and reads aloud a list from the book. Danni asks, "What book is that, book two?" Sam confirms it is book two and continues looking down, turning the pages. A few people reach for their books and turn to the page indicated by Sam.

APPENDIX L: DESCRIPTIONS OF ENVIRONMENTAL DOMAINS

The analysis of emergent codes from the interview data revealed patterns of domains, elements, facets and attributes that characterised the way people interacted with the dogs and the meanings they derived from them, which were reported in chapter 4. It also revealed patterns of domains and related elements, facets and attributes that characterised the environmental context within which people interacted with the dogs. These further patterns may help inform the answers to the research questions by providing a deeper understanding of the context within which participants described the characteristics of their interaction with the dogs.

Physical Domain

Seven students, Brad, Borat, Coral, Danni, Mary, Morgan and Sharon, described elements that for them characterised the physical domain. These elements were the physical layout of the room and the use of artifacts that included chairs, arrangement of desks, the use of space, computers, computer display, and learning guides. For example, Coral described the chairs as, “pretty uncomfortable.” She also explained that she could, “really only see the people on each side of me, and with the laptops up, I can’t see what’s happening there...one of the reasons I’m focussing is I’m actually finding it quite difficult to read the screen.” These comments were echoed by Danni, who said that the physical layout of the room made it difficult for her, and the students who were seated near her, to be able to see the computer display, and to see and have direct eye contact with the teacher. Danni explained that the physical layout created a, “shield in front of us,” that was like, “invisible cubicles around each one of us... it’s not a very interactive room the way they’ve got it set up. They either need less people, bigger room or just a better layout...it doesn’t work.” Similarly, Coral explained that the computers isolated students by, “

putting people into like a little universe, a little corral in the library, it's like you're in your own corral." Additionally Sharon explained that she felt, "real cramped and that affected me because I was sort of annoyed that I was cramped...the papers that I was given I couldn't put anywhere." However, Leigh explained that she felt more comfortable during the second week when, "there wasn't as many of us there, and we had more space."

A further characteristic of the physical domain described by both Mary and Morgan was the student learning guides that they felt were not used during the course. For example, Morgan explained that:

Say for instance I wanted to refer back to that book now I wouldn't know where to start, because neither of those books actually got explained. So for me to go and say, refer to those books if I needed to, to finish my final assessment, I wouldn't know where to start...and I carried them for those six days, and not once do I remember going, open it to the section that I should have been in.

In contrast, Brad saw the student learning guides as a reference source for information that he could not retain during the course, which he could use at a later time. He explained that, "The main thing I see with it is that you're not going to retain ten percent of the information I've been given here. Least you've got references to go back to it."

These results may suggest that for some students, the physical layout of the room and use of artifacts reduced visibility of other students and the teacher, constrained their socialisation with other students, and restricted the teacher's interaction with them. They may further suggest that for some students, the student

learning guides were seen as an unnecessary physical burden and may have been of limited benefit because students were not taught how to use them.

Task Domain

All participants except Mark, who participated in the event and post-course interviews, described elements that for them characterised the task domain. These elements were: the structure of the course; the congruence of teaching technique and learning styles and the resulting learning outcome as well as the personal and professional competence of the teachers.

Structure

All students except Brad and Mark, who participated in the event and post-course interviews, described facets that for them characterised the structure of the course. These facets were: direction, professionalism, organisation, homogeneity and time.

Direction was described by seven students, Borat, Danni, Leigh, Mary, Morgan, Sharon and Wynn timer, as students who knew what they were supposed to be doing and when they were supposed to be in attendance. For example, Borat explained that:

I didn't know that we were supposed to be here today, because somehow I thought that we are here on Friday, and this course finishes on Wednesday, you know. Second thing, yesterday I asked if we had to be here today, and I was told that we have to be here today, you know. And then I asked well, is it full day. And they said yes, it's a full day...then I realised that we are not here for a full day. We are here only until lunch or something.

Morgan echoed Borat's comments, and explained that changes to the timetable left her unsure when she was supposed to attend. She explained that she.

“didn’t have to go on the first day... I didn’t have to go for the Wednesday morning. But they changed it. And really I didn’t have to be there on Thursday morning.”

Similarly, Sharon explained that she was unsure when the course finished and when she should be in attendance because, “I thought the show was over, but it wasn’t over.”

Mary explained that students were given limited direction at the beginning of the course and that she, “didn’t think very much was explained at all about what would be happening in the time we were in the course, and what was expected of us.” This was echoed by Leigh, Sharon and Wynnie who described how they were given limited direction on the last day of the course. For example, Leigh said that, “No one knew what they were supposed to be doing on the last day.” Similarly, Wynnie explained that, “people felt, what are we doing here? We were all kind of left to our devices.”

Professionalism was described by five students, Coral, Danni, Leigh, Mary and Morgan, as the extent to which the course was innovative and conducted in a business-like manner. For example, Coral explained that she was disappointed because, “I actually came specifically to do this course because they promised an innovative approach... I was so depressed yesterday when I just saw they were stuck in the typical training scheme. I was really looking for best practice.” In the same way, Danni, Leigh and Mary described the course as, “not presented well,” and, “not professional.” For example, Leigh explained that she, “expected something far more professional for people who are paying money.” Morgan described professionalism in terms of the value of the service she felt she received and explained that, “I still paid for that service and by the end of it I was very

disappointed that we didn't get the one trainer...it was all over the place...and that was a lot of money that I paid."

Organisation was described by eight students, Andy, Dan, Danni, Leigh, Mary, Morgan, Sharon and Wynnie, as the logical sequence and organised structure of the lesson. For example, Mary said that the course, "doesn't seem to follow any set sequence, so there's a lot of jumping all over the place." This was echoed by Andy who described how the teacher presented information in an order that did not appear logically sequenced. Similarly, in the following interview excerpt, Danni explained that there was too much flexibility that led to undesirable student behaviours:

Yes, it was like, cause I made a comment to Morgan today, put a group of students whether they're five year olds or fifty years olds, I said, without any structure and look what happens. I was almost expecting the paper planes to start flying around the room, you know, and the chalk to be chucked from one end of the room to the other, you know, like when you're a kid. That's the way it was progressing. It was getting worse and worse and worse, and more unstructured.

Homogeny was described by two students, Danni and Mary, as the similarity between students. Mary explained that the group contrasted with her previous experience where, "although people may come from different working environments, they're probably more similar in that they're similar personality types I guess, yes." This was reflected by Danni who explained that she is, "used to being in workgroups and training sessions of people with like minded people. I don't feel that the class is matched."

Time was described by seven students, Borat, Danni, Leigh, Mary, Morgan, Sharon and Wynnie, as the pace of the teaching, duration of the course, and what was seen as time wasting. For example, Danni explained how she found the course was, “too drawn out...I could probably condense it into three or four hours. It [the video] is a time waster; it’s not what we’re here for.” Similarly, Morgan said that on the, “last day I did nothing,” and that she wanted the pace of the course to be “a lot faster...because I’m used to being on the go.” Mary explained that technology was partly responsible for the slow pace because the, “computer became a way of delaying doing anything,” and the, “equipment wasn’t operating effectively, so there were delays.”

Sharon and Wynnie said that they found it to be, “a long course.” However, Borat, Danni, Leigh, Mary, Morgan and Wynnie described time that was wasted. For example, Borat explained that, “the last two days were quite boring. I think that were not necessary these two days.” This was echoed by Mary who said, “There was time wasting happening,” and by Danni who said that the, “whole last morning was a total time waster. Alma went into class to waste time.” Similarly, Morgan said that, “I did find that [creating a flyer] frustrating, because again that was time wasted.” In contrast, Leigh described time being filled by irrelevant activities, and recounted that the video on the last day, “wasn’t related to the course, it was just a time filler.”

Reported in Table L1 is the frequency and distribution of comments made by students that characterised the structure of the course. Organisation, time and direction were the most frequency reported structural components. They were also reported by the greatest number of students.

Table L1

Frequency Distribution of Structural Characteristics

Participant	Direction	Professionalism	Organisation	Homogeny	Time	Frequency	Distribution
Andy			1			1	1
Borat	4				3	7	2
Coral		3				3	1
Dan			5			5	1
Danni	1	1	5	2	7	16	5
Leigh	3	3	3		1	10	4
Mary	6	2	9	1	3	21	5
Morgan	1	1	2		3	7	4
Sharon	1		1		2	4	3
Wynnne	2		1		3	6	3
Frequency	18	10	27	3	22		
Distribution	7	5	8	2	7		

Of those students who reported organisation, time and direction, four also reported that the structure of the course was characterised by the professionalism, which was also reported with a high frequency. Only two students reported homogeny as a characteristic of the course structure.

These results may suggest that for most students, the course structure was characterised by the logical sequence and organised structure of the lesson, the use of time, and the direction provided to student by the teachers. For some people, the course structure was characterised by the professionalism that did not meet their expectations for innovative practice and business-like conduct.

Teaching—Learning Style Congruence and Learning Outcomes

Five of the 12 students interviewed, Brad, Danni, Leigh, Mary and Morgan, stated that they were practical learners. They described how the task domain was characterised by preferred learning styles, the congruence of teaching style to their preferred learning styles, and the learning outcomes that they believed they achieved from the course. Reported at Table L2 is the range of comments made by students to describe these characteristics. These comments suggest that for some people, the passive learning style, use of computers and the lack of interactivity in the classroom did not meet their preferred practical and active learning styles. They also suggest that for some students, few learning outcomes were achieved from the course.

Teacher Competence

All students except Mark, who participated in the event and post-course interviews, described facets and related attributes that characterised the personal and professional competency of the teachers. These facets were self-efficacy, interpersonal skills and professional practice.

Table L2

Teaching and Learning Comments by Participant

Comments		
Participant	Teaching—learning style congruence	Learning outcomes
Brad	<p>I'm not into sitting down and listening.</p> <p>This is all foreign to me.</p> <p>I'm not into that design stuff.</p> <p>All training is done exactly like we did here today.</p> <p>[I'm a] practical learner.</p>	<p>Won't retain ten percent of information.</p> <p>That's all learning is to me, go back and reference it.</p>
Danni	<p>Not happy that it's computer work.</p> <p>Don't like sitting in class in front of computers unless I'm doing computer studies.</p> <p>Was expecting more participation, getting up in front of class and demonstrating that you are a trainer.</p> <p>[I was expecting] probably more participation.</p> <p>I don't find the course as stimulating as I would like it to be.</p> <p>Weren't brought together as a team by the facilitator enough.</p>	<p>I don't really think that I've got the full potential out of it that I could have.</p>

 Comments

Participant	Teaching—learning style congruence	Learning outcomes
Leigh	<p>I wasn't really happy with the learning style in the first week.</p> <p>Not delivered as I would have liked.</p> <p>Sitting and watching presentations was enjoyable.</p>	<p>I don't feel that as a trainer, I got particularly much more out of doing the course.</p> <p>I don't really feel I'm getting much benefit out of it. Apart from the fact that I will be able to say that I do have a certificate four.</p>
Mary	<p>Would have preferred to go through book and then use computer to write out work, rather than sit and scroll on the computer and not actually working progressively through books.</p> <p>Focus was on assessment, altogether.</p>	<p>It's just that you've come away from it feeling like you haven't learned anything.</p> <p>I was a little bit annoyed, so I'll remember that I was annoyed, that I didn't learn an awful lot, that I could have read the book and learned as much.</p>
Morgan	<p>I don't learn well in classroom</p> <p>Not stimulating.</p>	<p>I'm used to being busy.</p> <p>Not really, me personally,</p>

Comments		
Participant	Teaching—learning style congruence	Learning outcomes
	Classroom situation a bit boring.	no not really [learn
	Not enough hands on for me last week.	anything from the course.]
	Not compelling, not enough stimulation.	

Reported in Table L3, is the range of comments made by students to describe attributes of self-efficacy. These facets may be described as confidence, emotion and focus. Confidence was described as appearing to lack self-confidence or having difficulty with the task of teaching. Emotion was described as displaying negative emotions such as frustration or appearing unhappy. Focus was described as appearing distracted or preoccupied by activities outside the classroom, and showing interest in the task of teaching.

Reported in Table L4, are the comments made by students to describe attributes of interpersonal skills. These attributes may be described as rapport building, dealing with conflict, behaviour management, communication, and trust. Rapport building was described as being able to connect and relate to students, or appearing friendly, accommodating and understanding. Dealing with conflict was described as managing conflict in a positive manner through positive body language and behaviour. Behaviour management was described as controlling the behaviour of students and responding to behavioural clues. Communication was described as informing other teachers of students' progress and coordinating teaching activities,

Table L3

Comments Used to Describe Self-Efficacy

Participant	Comment
Confidence	
Andy	She was flat out doing what she was doing.
Andy	I reckon she lacks confidence.
Andy	She's got her head screwed on, she knows her job.
Emotion	
Borat	I think she was frustrated by that.
Borat	I think it was frustrating to Tanya.
Borat	She was not happy.
Borat	When Tanya came in I felt that she was frustrated.
Borat	I thought that some of these questions were frustrating Tanya.
Focus	
Borat	She came across as distant... she had to deal with something else.
Dan	She was very distracted.
Mary	I suppose discussing audits and how there's rush jobs before hand, which to my mind suggests that they are not preparing for their courses.
Mary	It was obvious she was disinterested in it.
Mary	I think she was finishing up there, so, it was sort of obvious.
Morgan	Cause she had the audit on the Thursday...I just got the feeling that her mind was on that.

Participant	Comment
Morgan	She just sat on the chair and there was no smiles...she sort of just sat not interested, bored.
Morgan	All we got to hear about was how she was getting audited...but we didn't actually get...I've found this works better for me, or that works better for me.
Wynn timer	Sam perhaps left them a little bit high and dry, but she's had a better offer.

and making decisions for students. Trust was described as appearing to act with pretence, showing self-interest, and being open to criticism.

Reported in Table L5 are the comments made by students that described attributes of professional practice. These attributes may be described as praxis, facilitating individual learning, presentation skills, technical knowledge, and experience. Praxis was described as the congruence between the teachers' displayed skills and knowledge and those being taught. Facilitating individual learning was described as providing guidance and assistance to individual students. Presentation skills were described as teaching in a logical sequence, verbal presentation skills, time management, appearing to know what they are doing, and creating interest. Technical knowledge was described as appearing to possess a lack of expert knowledge, and having superficial knowledge. Experience was described as appearing to have developed skills and experience in teaching in different situations.

Table L4

Comments Used to Describe Interpersonal Skills

Participant	Comment
Rapport building	
Andy	Whereas Alma, I couldn't connect with her.
Borat	They were very friendly, very accommodative, you know, very understanding. This morning a little bit, I don't know what, you know?
Leigh	I found Sam a bit sort of difficult to, not difficult but took a little while to warm to her.
Sharon	I didn't feel any connection with Alma as a trainer for myself.
Wynn timer	Other people didn't like her, but I related to Sam very well.
Dealing with conflict	
Andy	She was blushing mate...It knocked her up, eh?
Andy	She tried it with Sam once, I think, and Sam just cut her down. She was great, it was her job.
Borat	I expected Alma would have to retaliate, as she always had to do with Coral.
Brad	She didn't like criticism of her.
Brad	She's just took it personally really.
Brad	She was a bit taken aback there.
Brad	She sort of done it to Sam, and Sam sort of handled it a bit.
Morgan	I don't think she liked the fact that I told her, like me being the student as such, and her being the trainer.

Participant	Comment
Morgan	When Danni did say something...the look on Alma's face just changed. Again I think it was the whole control thing.
	Behaviour management
Borat	Alma should have done it [reinforced ground rules and controlled behaviour]...because you are the facilitator, you should say, "Hey, hey, come on."
Dan	It was unstructured, so they lost control.
Danni	If you put any of other younger people in the same position they...may have, you know, got it more back together.
Danni	She should have [controlled the behaviour], being a trainer, but she's only young.
Morgan	She wasn't in control as much as she should have been in control.
	Communication
Mary	They weren't communicating to each other.
Mary	Alma coming in on the last day and not knowing what had happened the day before with Sam, and planning on things and then Tanya coming in and thinking and, "Oh, you've already done that, oh, I didn't realise you'd done that."
Sharon	What I would have said to the student was, "Look I'm not going to be here tomorrow, this is what's going to happen, let me know what you think."
Sharon	[All decisions were made] by them.

Participant	Comment
Trust	
Andy	She's only got time for herself and no one else, man.
Mary	I don't think anyone would have questioned Tanya.
Mary	But she won't be getting a five from this person.
Mary	There was the assumption that they could sort of pull the wool over everyone's eyes and you know, we wouldn't ask any questions.
Mary	They assumed that nobody has really had a lot, had been to a lot of training

Only eight of the 82 comments used by students to describe the competence of teachers were framed in the positive voice, for example, "I think Sam's a very good trainer." The remaining 74 comments were framed in the negative voice, for example, "Alma took criticism personally."

Reported at Table L6 is the frequency and distribution of comments made by students to describe the attributes of each facet that characterised the competency of the teachers. This table shows a wide distribution of attributes amongst students with no discernable patterns between them. This may suggest that competence was defined by only a few facets that differed between students. Andy, Borat, Mary and Morgan were the most critical of the teachers' competence. Six of the eight positive comments were used to describe Sam's competence as her ability to deal with conflict, her presentation skills, ability to build rapport and experience as a teacher.

Table L5

Comments Used to Describe Professional Practice

Participant	Comment
Praxis	
Coral	This kind of flies in the face of good practice, I think.
Coral	How are we catering for individual learning styles here, you know?
Coral	I would have thought it [the assessment] was invalid.
Mary	Not catering for dis[abilities], something that we were supposed to be doing in our training.
Mary	[Not] catering for different needs. Didn't seem like they had really looked at that.
Morgan	With all of her experience and training maybe she could have said, "but this is how I find it."
Morgan	We got to hear about was how she was getting audited and all the rest of it, but we didn't actually get, "In the past I've found this works better for me, or that works better for me."
Morgan	Because they're telling me that I have to remember all these things and I have to make it interesting for my trainees.
Facilitating individual learning	
Danni	[She] didn't give us any guidance as to what we were supposed to do.
Mary	They didn't spend a lot of time with anybody.
Mary	They didn't come round, they didn't do the one-on-one.
Mary	They didn't check really to see if people, how people were going.

Participant	Comment
Mary	They did that sort of superficially.
Mary	I don't think they sat down with anyone unless they felt that they needed an awful lot of attention.
Mary	I don't think they were really aware of whether you could do what you were supposed to be doing.
Mary	I don't think, up until that stage that they were handed up, no one really knew what we were presenting.
Mary	It was just hit and miss for a lot of people I think.
	Presentation skills
Andy	And Alma, all the time, "Yes, yes, yes," you know. Oh, that drove me bloody mad.
Andy	Well, she repeated herself in a lot of different ways.
Andy	If you're learning something you start from <i>A</i> , you go to <i>Z</i> . You don't go from to <i>A</i> and you go to say, <i>G</i> and then go back to <i>B</i> .
Andy	Sam's blunt, she's straightforward, pulls no punches, mate, gets the message straight through.
Coral	The deliverer is trotting against the clock.
Danni	They were confused too as far as what they were supposed to deliver to us.
Danni	She was sent into that classroom to waste time.
Mary	I don't think it's very well prepared.
Mary	They didn't look like they quite knew what they were doing.

Participant	Comment
Mary	The actual students presenting were more interesting than the presenters.
Mary	If the teacher was talking about topic x and there was an interruption of some sort, they would immediately go onto topic y .
Wynn timer	I think Sam's a very good trainer.
	Technical knowledge
Mary	Didn't feel like the teachers had knowledge about, except some very basic stuff, they knew they had to, show that they were knowledgeable.
Mary	They knew the right things to say, but when it came to the nitty gritty of teaching the course, that was left to whatever.
Mary	Sam knew parts of what she was teaching.
	Experience
Borat	It is a quite new organisation, they are just learning themselves, you know.
Borat	Sam is very broadly skilled in training.
Dan	And that may have been due to the inexperience of the trainer.
Danni	She should have, being a trainer, but she's only young.
Wynn timer	Alma..., said doesn't normally do the end part of it, she doesn't do it.

Table L6

Frequency Distribution of Competency Facets and Attributes

Participant	Self-efficacy			Interpersonal skills				Professional practice					Frequency	Distribution		
	Focus	Emotion	Confidence	Rapport building	Dealing with conflict	Behaviour management	Communication	Trust	Praxis	Facilitating individual learning	Presentation skills	Technical knowledge				
Andy			3	1	2			1			4			11	5	
Borat	1	5		1	1	1								2	11	6
Brad					4										4	1
Coral									3		1				4	2
Dan	1						1							1	3	3
Danni						2					1	2		1	6	4
Leigh				1											1	1
Mary	3							2	4	2	8	4	3		26	7
Morgan	3				2	1				3					9	4
Sharon				1				2							3	2
Wynnne	1			1								1		1	4	4
Frequency	9	5	3	5	9	5	4	5	8	9	12	3	5		82	
Distribution	5	1	1	5	4	4	2	2	3	2	5	1	4			

The most common attributes that characterised the competence of the teachers were: focus, that is, showing interest and being distracted or pre-occupied; and rapport building, that is, being able to connect and relate to students, or appearing friendly, accommodating and understanding. Being able to manage conflict in a positive manner through positive body language and behaviour, manage student behaviour in the classroom, teach in a logical sequence and create interest, and the professional experience of the teacher, were also common attributes of competence that were reported by four students.

These results may suggest that for most students, the teachers' competency was characterised by facets of self-efficacy and interpersonal skills, specifically their focus on the task of teaching, showing interest, and their ability to build rapport with students. Two attributes of interpersonal skills, dealing with conflict and behaviour manager, as well as two attributes of professional practice, presentation skills and teaching experience, were also important attributes that characterised the competency of teachers.

Cognitive Domain

All participants, who participated in the event and post-course interviews, described elements that characterised the cognitive domain. These elements were: the volume and complexity of the lesson content; and the role of distraction.

Cognitive Load

Six of the 12 students interviewed after the course, Brad, Coral, Dan, Mary, Sharon and Wynnie, along with the teacher, said that they found the volume of course content challenging and required focus and concentration. For example, Brad described the course as, "all a bit mind boggling...the main thing I see with it is that you're not going to retain ten percent of the information." Similarly Coral explained

that, “there’s a huge volume of work which not necessarily everyone is aware of how much, of what we’re skimming across the top of a pretty big iceberg...you do have to be pretty focused.” Additionally, Mary said that, “When I got home at the end of each day I thought, what was that about?” These comments were echoed by Dan who said it was, “a long course,” and by Sharon who said, “when I first saw that’s what we were facing I thought oh, how are we going to do this.” Sam also described course as, “full on...very much information overload.”

Distraction

Six students, Borat, Danni, Leigh, Morgan, Mary and Wynnie, as well as the teacher, said that they and others became distracted by the computers and used them to check emails, play games and look up websites. Danni, Leigh, Mary, Morgan and Wynnie, explained that they and other students became distracted by the computers because, as Wynnie explained, they were: “just misbehaving. Well, we were bored. We were sitting on a computer looking at real estate and doing horoscopes and I was looking at jobs, and Danni was looking at jobs.”

Danni explained that people chose to distract themselves by using the computers because it was convenient, and drew less attention than by being distracted by the dogs because, “I didn’t want to be caught out, you know. So I think people can interact with their computers and not feel caught out, or that they’re seen as being involved, but they’re not.” Similarly, Mary said that she found the use of mobile phones distracting. However, Morgan and Sam described computers as a negative distraction. Yet Sam explained that, “the computers [were] more of a distraction than the dogs.” This resonates with Danni’s comment that Andy interacted more frequently with the dogs than other people because he, “didn’t have a laptop in front of him, see, to keep his mind elsewhere.”

Seven students, Andy, Dan, Danni, Leigh, Wynnie, Mary and Sharon, as well as the teacher also described how they were distracted by the behaviour of other people such as Reggie walking around the room, Coral challenging the teacher, and students getting coffee. Dan explained in the following interview excerpt, that these behaviours were more distracting than the dogs:

It was just a distraction. I completely lost the plot what was going on. I was watching her, what she was doing, you know. It was a distraction for quite a while. In fact that was more of a distraction than Adonis. And when she put her laptop on the thing, I was watching the whole process. She's putting the box on the desk, and the laptop on it. I understand why she was doing it, but I thought what's going on, you know. And then she went out and she stood next to Sam, and watching her it was a major distraction for me. Even to the extent that we were discussing it on the way home, you know.

Affective Domain

All people who participated in the event and post-course interviews described elements that characterised the affective domain. These elements were: the emotional climate operating within the classroom; the motivation of students to attend the course and to learn during the course; and empathy with others.

Emotional Climate

All students except Mark, who participated in the event and post-course interviews, described facets that for them characterised the emotional climate in the classroom. These facets were: annoyance, anxiety, disappointment, frustration, sufferance, unhappiness, friendliness, comfort, happiness and supportive.

Annoyance

Students explained that annoyance was derived from a variety of sources. Sharon explained that both she and Dan were, “annoyed about the point where a group decision had been made with only one person deciding.” Dan also felt annoyed, “when we were told about not to watch the video...I was annoyed.” He also explained that he became annoyed at, “having somebody like Andy with the problem he’s got, really stood out for me. I found it annoying in some respects in that I had to slap my wrists and say, ‘Well look, he’s got problems.’”

Mary explained that she became annoyed because she, “didn’t learn an awful lot...that I could have read the book and learned as much.” Leigh explained that she became annoyed because she, “felt it [the course] to be a bit unorganised.” She also explained that she saw students receiving privileged treatment from the teachers, which she found, “a bit annoying and particularly when you’re being told you haven’t done stuff properly or there are people that are getting their work done for them.” Morgan explained that she became annoyed when told to attend on the wrong day. Sharon explained that she became annoyed by the limited desk space, and said that other people were annoyed at Coral for challenging the teacher.

Anxiety

Danni explained that she and others became anxious on the last day when, “we were the three that were probably of all of us, were a bit more tense about the whole affair than anyone else, and that dog seemed to calm down to us.” Similarly, Dan described anxiety implicitly in inverse terms, when he said that the dog made the environment, “more peaceful perhaps.” In the same way, Leigh said that, “so we just have a giggle to break the tension.”

In contrast, Sam in the following interview excerpt said that she became anxious and stressed during the course because of situations outside of the classroom:

Tuesday night I had a couple of phone calls from home. My son had gotten drunk, gone off the rails. So I got up Wednesday morning, I didn't have any reception on my phone on Tuesday night. So Wednesday morning I got up and I had a phone call from his girl friend, a phone call from his ex-girl friend. So, also a couple of nasty SMSs from my sister because she'd been involved in the situation. So I came into work Wednesday morning, not knowing what had happened, wasn't able to contact, you know, make return phone calls, didn't know what had happened. So I've come into work extremely stressed.

Disappointment

Coral, Leigh, Mary and Morgan explained that disappointment was derived from the structure of the course. For example, Leigh stated that, "it didn't really meet our expectations." In the following interview excerpt, Morgan explained that she became disappointed that the teachers did not share their experience:

Like all we got to hear about was how she was getting audited and all the rest of it, but we didn't actually get, "In the past I've found this works better for me, or that works better for me." So I was a little bit disappointed in that...I was very disappointed that we didn't get the one trainer, the whole time, cause it was all over the place.

Frustration

Eight students, Andy, Borat, Brad, Danni, Leigh, Mary, Morgan and Wynn timer, described how they experienced frustration arising from elements of the

task environment that included structure, learning styles and outcomes, and teacher competence. For example, Andy explained that he was frustrated by Alma's presentation skills, "and Alma, all the time, 'Yes, yes, yes,' you know. Oh, that drove me bloody mad." Similarly, Borat explained that, "it just makes me mad that Sam said...we need to be here...she said this training course, you are here because you need to be here. No way, no. I don't need to be here." He also said that the teachers were frustrated because, "they'd done it already before," and that one teacher, "carried that frustration into this class when she entered." Borat also described how he thought that, "some of these questions were frustrating Tanya." He further explained that he became frustrated with other students who were not assisting others when, "we were stapling stuff together, she didn't want to pass the stapler, yes. It's like, come on. Yes I did [get frustrated by that.]"

Danni explained that the lack of structure and what she saw as time wasting made her feel, "just pissed off, you know, that they, they should be organised. They should have a contingency plan." In the following interview excerpt, she also said that she found the lack of homogeny in the group and her own boredom to be frustrating:

If I just reflect back on myself I think I'm used to being in workgroups and training sessions of people with like-minded people. So I found that a little frustrating...my boredom is, like yesterday I was pretty frustrated with it. I respond a bit more to more stimulation.

Similarly, Leigh also explained that she was frustrated by other students and said that, "you can get really frustrated with people around you at times." Danni further explained that she saw, "a lot of them [students] probably were starting to get a bit frustrated," because students wanted to go home on the last day rather than

watch the video. This was echoed by Morgan who said that, “I did find that frustrating, because again that was time wasted.”

Danni’s frustration at the course structure and teaching style was echoed by Leigh who explained that she found, “this method of teaching a little bit frustrating.” She said that students did not know what they were supposed to be doing and, “people were getting really frustrated and to a point where it just got to the stage of what are we doing, can we go?” She also acknowledged other people’s frustration during the course when she said, “we all cared that we were getting frustrated at times.” Mary explained that she became frustrated because she had, “left work to come to a course, and you know there’s stuff you could be doing at work and it’s frustrating cause I know how much work I’ll have when I go back.”

Sufferance

Danni described sufferance at the lack of organisation, and said, “because they were unorganised, we had to suffer for it.” This was echoed by Mary who described release from sufferance by saying, “Thank God it’s over.”

Unhappiness

Danni and Leigh both stated that they were unhappy that their learning styles were not being met, and that the teachers relied on students using computers. For example, Leigh explained that, “I wasn’t really happy with the learning style. I was unhappy...because of the way the course was presented.” Leigh’s comments were echoed by Danni who said that she was, “probably not entirely happy that its computer work.” Morgan and Borat described how Alma became unhappy on the last day when Danni voiced her concern about watching a video. Morgan said that she saw, “her face changed, and her whole happy-go-lucky changed.” Similarly, Borat said that, “something happened in the morning that she was not happy about.”

Positive characteristics

Brad and Borat described the emotional climate created by the teachers to be friendly and helpful. For example, Brad explained that, “They were good, they made me feel as though I wasn’t a, you know, bloody leper or something.” Similarly, Borat said that the teachers were, “very friendly, very accommodative, you know, very understanding.” Leigh described comfort as an aspect of the emotional climate that increased over the duration of the course, and said, “I was more comfortable with the group in the second week.” Mary described the emotional climate when students were presenting to each other as supportive, and that students were, “being reassuring and giving positive feedback. I think they were trying to support the people that were up there. Morgan explained that happiness for the teacher was derived her control over students said, “Well, she was relatively happy, cause we were all there and doing nothing, but we were all there. And it was like she had control, you know, of the class.” In contrast, Wynnie described both herself and Sharon as people who had a happy disposition and were, “basically happy.”

Summary

Reported in Table L7 is the frequency and distribution of characteristics of the emotional environment described participants. Negative characteristics were mentioned by all participants, yet positive characteristics were described by only six. Frustration and annoyance were the most frequently described characteristics. These results may suggest that for most people, the emotional climate in the classroom was characterised by frustration arising from elements of the task domain, that dictated the structure of the course, teaching—learning

Table L7

Frequency Distribution of Emotional Characteristics

Participant	Negative						Positive				Frequency	Distribution
	Annoyance	Anxiety	Disappointment	Frustration	Sufferance	Unhappiness	Friendliness	Comfort	Happiness	Supportive		
Andy				2							2	1
Borat				4		2	1				7	3
Brad				1			1				2	2
Coral			1								1	1
Dan	3	1									4	2
Danni		1		4	1	1					7	4
Leigh	2		1	6		2		1			12	5
Mary	1		1	1	1					1	5	5
Morgan	2		3	1		1			1		8	5
Sam		1									1	1
Sharon	8						1				9	2
Wynn timer				1					1		2	2
Frequency	16	3	6	20	2	6	3	1	2	1	60	
Distribution	5	3	4	8	2	4	3	1	2	1		

style congruence and learning outcomes, and teacher competence. Annoyance was also characteristic of the emotional climate for some people.

Motivation

Eight of the 12 students interviewed, Andy, Brad, Coral, Danni, Leigh, Mark, Mary and Morgan, stated that they were required to complete the course as part of their employment. All of these students except Coral were paid by their employer to attend the course, who also paid the course fees. Leigh and Brad explained that they were required by their employer to attend the course however, their attendance appeared under duress. For example, in the following interview excerpt, Brad said that his continued employment was dependent on completing the course:

If they didn't send me down here to do it, I wouldn't be here. You got to do it, you do it. If I don't do it, I haven't got a job, haven't got this job. I rang the boss up yesterday and said to this fellow, 'I'm still working for you at the moment, hopefully I'll still be working for you tomorrow. Take me bat and ball and go home.

Brad further explained that his motivation to attend the course was also influenced by the use of computers as well as the dogs and that when he saw the computers he, "bailed up straight to the door...Then the dog, I thought, what am I getting into here? I didn't want to be here in the first place...I thought, my God, someone out to get me here."

Sharon and Dan were self-employed and paid for the course fees and their time to attend the course. Their motivation to attend was derived from improved employment and business opportunities. Borat and Wynn timer funded their attendance, which was motivated by improved career opportunities. Mary said that, "cost is a

factor and it's cheaper than some courses, and that would've been an incentive for people who just want to get the certificate." Sharon explained that people's motivation to attend may have had an impact on how other students perceived them, and said that, "people who don't want to be there are aggressive."

Reported in Table L8 is the frequency and distribution of characteristics of student motivation during the course described by participants. These students described how they became bored during the course, were not stimulated, and that the teachers did not create interest. For example, Morgan said that, "the course wasn't interesting, do you know what I mean? Like it wasn't made interesting for us to get involved... I find the whole classroom situation a bit boring." Similarly, Borat said that he felt, "bored, bored, bored to death." In the same way, Brad said that he had, "been yawning my bloody head off."

In contrast, Mary said that students were interested in the presentations given by other students, which she believed were more interesting than the presentations given by the teachers. However, Sharon explained that after people had given their presentations their interest appeared to wane. For example, she said that Borat was, "very enthusiastic in the beginning and then it was almost like a curtain went down, he just lost interest in everything. I think after his presentation. He just kind of like, switched off. Didn't really care." This was echoed by Wynnie, who said that, "I think a lot of people, once they did their assessment, I think they thought that was it...they really didn't want to be here because they did their assessment on Wednesday." Wynnie also explained that people's motivation towards the end of the course waned because, "it's like a Friday...they say don't buy a car on Monday or Friday, you know cause Monday, the bloke's thinking

Table L8

Frequency Distribution of Motivation Characteristics

Participant	Negative			Positive	Frequency	Distribution
	Boredom	Lack of interest	Not stimulating	Interest		
Andy	2				2	1
Borat	2				2	1
Danni	1		3		4	2
Leigh	1	1		1	3	3
Mary		2		2	4	2
Morgan	7	3	3		13	3
Sharon	2	1			3	2
Wynn timer	3				3	1
Frequency	18	7	6	3	34	
Distribution	7	4	2	2		

about his weekend, and Friday he's just thinking about the weekend. And I think that's what today was." Similarly, Brad likened it to approaching the end of a journey and said, "it's like being on a trip. You're coming to the end of the journey you start to relax a bit."

These results may suggest that students' motivation to attend the course was characterised by a need to attend as part of their employment, and the desire for

growth and development. They may also suggest that for most people, motivation during the course was characterised by boredom and lack of interest arising from the teaching style.

Empathy

Five students, Andy, Borat, Dan, Leigh, Sharon and Wynn timer, along with the teacher explained that they were concerned for other people in the classroom who experienced injuries, illness and allergies. For example, in the following interview excerpt, Andy expressed his concern for Alicia, Adonis' handler:

Feel sorry for her, I didn't know she had bloody tumour, brain tumour. I knew there was something wrong with her cause she had that scarf wrapped around her head and she was bald. Yes, poor bugger. See, you don't know, you don't know how lucky you are with your health mate.

Similarly, Danni explained that that people have to, "make allowances for, you know people with a disability or a situation where they have some special needs." However, she contrasted this concern with a lack of tolerance for people and said that she, "wasn't prepared to have that as part of my, you know, my classroom." This empathy conflict was echoed by Sharon and Dan. For example, Sharon explained that she and Dan saw themselves as tolerant people who were, "pretty good with people who have got disabilities or special needs or that sort of thing." However, in the following interview excerpt, Dan explained that he was not as understanding as Sharon may have suggested:

I think having somebody like Andy with the problem he's got, really stood out for me. Made me really aware, you know. I found it annoying in some respects, in that I had to slap my wrists and say well look, he's got problems. I've never actually seen that in a training course, I've never seen it happen

before, but I've never had so many people with special needs in one training course.

The empathy conflict was also echoed by Borat who acknowledged Reggie's disability, yet said that, "she's a little bit strange to me, she acts strangely." Sam suggested that this empathy conflict may have been because people believed that Reggie used her medical condition as an excuse, and that, "They were understanding of her disability, however she played on it, which made people not like her. Because she used it to try and get out of a million things." This was echoed by Andy who said that Reggie, "was allergic to dog hair and all that, I think that was just her excuse. She had different issues mate, and it wasn't nothing to do with the dog." Sam contrasted Reggie's situation with Andy's, and said that he, "didn't play on his disability. He was there, he just, you know, he didn't isolate himself." In contrast Leigh said that she believed that, "everyone cared for Reggie, like, you know, to accommodate her...and I don't know, I thought we were a pretty caring group."

Borat expressed concern for Andy whom he said was, "on a lot of pain killers, he's very mellow...the amount of pain that he is under must be incredible." This concern for Andy was echoed by Wynn timer who said, "what do you do for someone in pain like Andy? I know at one point I asked how is back was today. I think he was on those pain killers...he was in a fair bit of pain." Wynn timer also compared her concern for Andy with concern for Reggie, and described Reggie as, "an attention seeker, and...people sometimes do that for attention...Andy's there and I don't know if you noticed, but he kept going to the doctor...and he doesn't carry on like that."

Social Domain

All participants who participated in event and post-course interviews described elements that characterised the social domain. These elements were human agency and socialisation.

Human Agency

All participants except Mark, described facets that characterised their human agency. Bandura (2001) describes human agency as the capacity of people to exercise control over how they operate in the world. However, participants described characteristics that limited this capacity. Participants described these limiting facets as: dominant voice; fear of retribution; prejudice; acquiescence; roles and hierarchy; and normative behaviour. Reported at Table L9 are summary descriptors of these facets, which were drawn from people's descriptions of them.

Dominant Voice

Four students, Borat, Danni, Morgan and Sharon, described characteristics that distinguished the dominant voice as speaking on behalf of others, being the dominant voice, not involving others in decision making, and not informing others about matters that affected them. For example, Sharon explained that she was, "quite annoyed about the point where a group decision had been made with only one person deciding." This was echoed by Danni who described herself as, "their voice, I worked out by...trying to acknowledge what I'd said was they would like as well, without anybody feeling that I was talking them into something they didn't want." Morgan described the dominant voice by saying that, "if Danni didn't say anything I don't think anyone would have got the opportunity to say anything. There was not a lot of opportunity to say anything."

Table L9

Description of Facets of Human Agency

Facet	Description
Dominant voice	Speaking on behalf of others, being the dominant voice, not involving others in decision making, not informing others about matters that affected them.
Fear of retribution	Anticipated reprimand from the teacher, fear of attracting attention and being negatively labelled with limiting consequences. Fear of offending others, intimidating stares from the teacher, generalised implied threat.
Prejudice	Others being seen as receiving privileged treatment.
Acquiescence	Acceptance of the situation and going along with things, seeing no value in or not wanting to speak up and acceptance of others' behaviour.
Roles and hierarchy	Roles where students are seen as subordinate to teachers, that influenced what students felt they could and could not say. Likened to a poker game where people cannot be themselves and felt they must play within the expectations of a particular character such as teacher, student or professional.
Normative behaviour	Establishment of unspoken social rules where students felt they were required to sit in their seat and were not allowed to get up to get a drink, go to the toilet or pat the dog. Social

Facet	Description
	<p>norms established from childhood education experiences where students were required to remain in their seats at all times, and where there is secrecy amongst students by passing notes in class. Rules that determined what was acceptable behaviour such as getting up to get a drink and confronting other students, and what was unacceptable behaviour of students such as the use of mobile phones during class, confronting the teacher, other students seen to be invading personal space, and comments by the teacher that were seen as inappropriate.</p>

Danni also described the dominant voice by explaining that, “everybody looks at the needs of a person, but [not] the needs of the rest of the group... Like we’ve been informed about a dog in the classroom, how do we feel about that, and had an opportunity to respond.”

Fear of Retribution

Five participants, Borat, Coral, Mary, Morgan and Wynn timer, described characteristics that distinguished fear of retribution as fear of reprimand from the teacher, fear of attracting attention and being negatively labeled with limiting consequences, fear of offending others, intimidating stares from the teacher, and generalised implied threat. For example, Borat described how he felt that speaking up would draw attention by singling him out, which may have had negative consequences. Boart explained that, “if you could speak up well, you are the tallest,

you speak up, well they will never forget you...and it's going to be good in some cases, but it could negatively impacting your future, you know."

Morgan and Wynnie explained that fear of retribution was characterised by intimidating stares received from the teacher and the fear of being caught. For example, Morgan explained that when she went to assist another student, "the look I got from Sam was like, you shouldn't be doing that." Similarly, Wynnie explained that when she laughed at Adonis when he wandered under the tables, she thought that she would, "get in trouble over that. I was just waiting for someone to get up me." Coral described fear of retribution that arose during the event interview when she said that, "this is very difficult to have this conversation here. I'm very concerned that we're recording this...I don't want any feedback." Immediately following these comments Coral requested that the tape be turned off for part of the interview. Mary described fear of retribution through generalised implied threat and stated that, "No one would question Tanya." Borat explained that fear of retribution was also characterised by a fear of offending others, and said that, "I wanted to tell her [Danni] she should wear more white, but I didn't because I thought, hey, you know, maybe she would think that this is not for me to comment on.

Prejudice

Leigh described prejudice as others being seen as receiving privileged treatment, "that can be a bit annoying and particularly when you're being told you haven't done stuff properly or there are people that are getting their work done for them."

Acquiescence

Six participants, Andy, Borat, Leigh, Danni, Mary and Morgan, described characteristics that distinguished acquiescence as acceptance of the situation and

going along with things, seeing no value in or not wanting to speak up, and acceptance of others' behaviour. For example, Borat explained that completing administrative paperwork was a, "normal procedure so you go along with it, you know?" Mary explained that people accepted the situation because she felt, "it wouldn't get them anywhere, really...everyone's going to pass this anyway, so does it really matter? Are they going to fail us?" Danni, Leigh and Andy described acquiescence as people's desire to speak up. For example, Andy's said that, "you didn't hear anyone else complain." This was echoed by Danni who said that, "anybody that wanted to say something probably said it at the time...there was not too many opportunities arose where we'd want to challenge."

Roles and Hierarchy

Three students, Borat, Mary and Morgan, described characteristics that distinguished roles and hierarchy as students being seen as subordinate to teachers, which influenced what students felt they could and could not say. For example, in the following interview excerpt, Borat likened the roles and hierarchy to a poker game and to acting, where people felt that they must play within the expectations of a particular character:

It's like a poker game, you know. You can't be yourself because you are expected to do certain decisions and therefore you have to be the person you are employed as. So what I'm saying is that you have Alma who is trainer, and she has to be trainer, so she plays trainer. It's like acting, you know? I'm acting to be a student or trainee, but also you have got other agendas. I'm unemployed now so I don't give a [damn]. But you've got guys like Danni, she is trainer and assessor... therefore she is not just playing to be trainee, she is also playing to be this health and safety, occupational trainer and

assessor. So she still plays two roles, you know...I have nothing to play here. I'm here for myself. I don't have to be here. I want to be here.

Morgan explained that roles and hierarchy were characterised by roles of teachers and students, and said that, "I don't think she liked the fact that I told her, like me being the student as such, and her being the trainer. I don't think she liked the fact that I told her." Similarly, Mary explained that the roles people played made, "a big difference, the position they were holding in that group. What you could say and couldn't say. Sam was in a position of authority as a trainer...whereas Andy and everybody else was there as a student."

Normative Behaviour

All participants, except Coral and Mark, described characteristics that distinguished normative behaviour as the establishment of unspoken rules regarding acceptable behaviour. They said that students felt they were required to sit in their seats and were not allowed to get up to get a drink, go to the toilet or pat the dogs. For example, Andy, Brad, Danni, Mary and Sam said that Coral's behaviour when she challenged the teacher was not acceptable. This was exemplified by Andy's comment that, "as far as I'm concerned, that's bloody rude." Similarly, Brad said, "I think they all felt like I did, you know, she was a bit out of place." These comments were echoed by Wynn timer who, in recalling the way Danni challenged the teacher, said that, "she did it in a manner that was maybe a little rude, but that's Danni's nature."

However, Dan and Sharon explained that they saw Reggie's behaviour when she spoke against Coral as acceptable behaviour. For example, Sharon explained that she, "didn't actually have a problem with that. I just felt she had her own views about things and she had a specific belief system and she was sharing it...and

personally I think well, if she can't voice it then we're not very democratic." This was echoed by Borat who explained that Reggie's behaviour was congruent with one of the social agreed ground rules that were written on the whiteboard. However, in the following interview excerpt, Borat explained that these formal social rules held little value and meaning for students, and likened them to the act of preparing a budget:

Yes, we were just sitting there, just watching it, you know kind of getting ride, when Reggie said, "Hey, relax this is, just not even five minutes ago we put all these rules down and you are ignoring them now," you know. I think they were surprised, I was surprised, you know. I mean it was just a simple thing that we put up five minutes ago and we all forgot about it. Yes, yes, because you know I think people do, it's like one of those things, when you have put a budget. You know people perceive it as bullshit, even though we participate in it, we put data, you know. You submit it to your boss, your boss works with it, he submits it to his boss. We work on it, we put what we want, and we still don't, you know like these rules. I mean come on, it's, let's say what you want your rules to be and then you do it and then you forget about it. It's weird.

Sam described how characteristics of normative behaviour were influenced by the experience of, "being a classroom situation I think that old learning comes in where you know, you don't get out of your seat, unless you really have to." This was echoed by Morgan who described how unspoken rules, "made me feel like I had to sit in my seat... the first two days I didn't drink there... I didn't even go to the toilet the first two days I was there. I came home here at lunch time."

In a different way, Leigh and Mary described the acceptable behaviour of

others. For example, Leigh explained that, “I’m just being overly sensitive to it because in particular she’s sitting next to me and she’s very much invading my space.” This compares with Mary who described the behaviour of the teacher as unacceptable and said that, “I suppose discussing audits and how there’s rush jobs before hand which to my mind suggests that they are not preparing for their courses.” In the following interview excerpt, Mary compared the use of mobile phones with getting a drink:

Well, I do find the mobile phone, well, it’s one non-rule, a bit unusual. And I find that distracting. But getting up and getting water or coffee doesn’t bother me, and I’m probably used to that because of my work environment where we have a lot of meetings, that people do have to get up and go to other things, to answer phones or something in a meeting. So that doesn’t bother me that much. But, certainly having a mobile phone in the room, and letting it ring and then answering it...while someone’s presenting. Yes, that surprised me and no one said, “People could we turn our phones off?” That surprised me, cause I think that’s a really simple thing to say, and I don’t think anyone would take offence.

Reported at Table L10 is the frequency and distribution of comments made by participants that they used to describe characteristics of human agency. The characteristic most frequently described by all participants, with the exception of Coral, was the establishment of normative rules regarding behaviour. Human agency, acquiescence and fear of retribution, were also frequently described characteristics. For four students, human agency was also characterised by the

Table L10

Frequency Distribution of Human Agency Facets

Participant	Dominant voice	Fear of retribution	Prejudice	Acquiescence	Roles and hierarchy	Normative Behaviour	Frequency	Distribution
Andy				1		1	2	2
Borat	1	3		2	1	2	9	5
Brad						1	1	1
Coral		4					4	1
Dan						1	1	1
Danni	2			2		2	6	3
Leigh			1	2		1	4	3
Mary		1		2	1	3	7	4
Morgan	2	3		1	1	2	9	5
Sam						3	3	1
Sharon	1					1	2	2
Wynnne		1				1	2	2
Frequency	6	12	1	10	3	18	50	
Distribution	4	5	1	6	3	11		

dominant voice, which was reported on six occasions. These results may suggest that human agency was characterised primarily by the establishment of social norms and unspoken rules regarding acceptable and unacceptable behaviour, acquiescence, and fear of retribution from the teachers and other students.

Socialisation

Ten of the 13 participants interviewed described facets that characterised socialisation. These characteristics were: forming, storming, mourning, movement, visibility and interaction.

Forming

Four students, Dan, Mary, Morgan and Sharon, described characteristics that distinguished forming as being introduced to and getting to know others and group cohesion. For example, in the following interview excerpt, Morgan explained that she was concerned about joining the group on the second day:

I was a bit worried, like before I went there...they know each others' names and they know all the rest of it. And I'm coming in on the second day knowing nothing, and they know everything...and the other thing too when I first walked in, it was like they'd forgotten I was even coming, cause...they went, "Uh-huh, what are you here for?."

These comments were echoed by Dan who described how Morgan, "come from nowhere to me, I didn't see her the first day. She just appeared one day, and I thought, 'Oh, where have you come from.'" Similarly, Sharon explained that, "all of a sudden there was this person...she just appeared. I thought at first she was a trainer that was going to take over." In the same way, Mary described forming as, "just the general feel of the whole place was, walking in the front door, not being greeted really, no one directing that, "it took a while for everyone to sort of settle in, and feel comfortable."

Dan described forming as the development of group cohesion where students were seen as part of a team. For example, Dan explained that because Coral said she was, "only here to do this...and I'm going, I thought, 'Oh well, you're only

here for a few days and then we won't see you.' So I never felt she was really part of the group." Similarly, Sharon said that she felt there was a lack of group cohesion because, "there was a group of two. There was that side and our side...and I could probably then say Coral and Wade cause they were the two people who were only staying for a short time."

Storming

Danni, described storming as the contribution of conflict to group cohesion, and explained that Coral became socially isolated when she challenged the teacher. She said that Coral, "alienated herself from everyone, and it brought the group together those that felt the same way...It sort of drew those people together."

Mourning

Four students, Dan, Mary, Sharon and Wynnie, described characteristics that distinguished mourning as saying goodbye and the expected socialisation beyond the course. For example, Sharon explained that, "nobody said, 'Let's go and have a lunch together, or a coffee or let's catch up.' There were no exchanging of telephone numbers...It's almost like we never want to see you all again." Conversely Sharon also stated that she believed some people, "were almost saying goodbye too soon, they wanted to say goodbye." Sharon's comments were echoed by Dan who said, "I've never seen a course finish as abruptly as this course. So, after spending eight or nine days with people, you do want to say goodbye, and no one really said goodbye did they?"

These comments resonated with Mary who in the following interview excerpt, said that she would possibly meet Leigh outside of the course, but that she did not have any expectations of developing a relationship with other students:

I think it's like any big group of people together, you can have a chat to them and you think that's it, we probably won't have a, any sort of relationship or friendship outside of this team, so. No, I said to Leigh that I might meet her again, but that's because Leigh's probably in the line of work that I may get to see her and speak with her...I didn't go there to meet people, I went there to get the certificate.

Wynn timer also described mourning by saying that she had asked people why Reggie had left early, but that, "no one answered me. It was like, no one wanted to know or no one knew. It was just weird."

Movement

Three students, Dan, Morgan and Wynn timer, described characteristics that distinguished movement as changing seating positions and movement within the classroom. For example, Dan explained that not moving seats during the course was unexpected because, "a lot of courses they move people around don't they? We were always going to sit next to each other on the first day, but I was prepared to move the next day." Similarly, Morgan stated that students, "didn't move anywhere," during the course, and said that, "I don't know why... But for some reason, your computer was put in that chair, which was the same chair that you sat in the day before." These comments were echoed by Wynn timer who explained that, "if you'd moved me over next to say Mary or Leigh, they probably would have, like I would have got to know them better too."

Visibility and Interaction

Eight participants, Brad Carol, Dan, Danni, Leigh, Mary, Morgan and Sam, described characteristics that distinguished visibility and interaction as being able to see others and the opportunity to talk and interact with them. For example, in the

following interview excerpt, Coral explained that the computers and the physical layout of the room reduced both visibility and social interaction:

I can really only see the people on each side of me, and with the laptops up... I can't see what's happening there... It's very interesting what technology's doing. It's really putting people into like a little universe, and little corral in the library. It's like you're in your own corral. It's fascinating.

This was reflected in Sam's comment, that students "weren't in a group, and they were very isolated too." However, Leigh said that she did not feel isolated by the computers. Danni and Mary explained that they had limited interaction with others because, as Mary explained, "the set up has contributed to it, and everyone was sort of a long way away. I didn't get to talk to Sharon and Dan at the other end at all until, I think the last day."

Brad, Coral, Dan, Danni, Mary, Morgan and Sam described how they did not have the opportunity to interact with others during the course. For example, Brad explained that he interacted only with those people who were seated close to him, and that, "those fellows there could have been on the moon, I didn't have anything to do with them. Didn't you know, definitely weren't interactive with them." This was echoed by Danni, who said that she, "never had a conversation in seven days. Never had a conversation," with Sharon and that, "I didn't have a conversation probably with a couple of other people either." Dan explained that he interacted with Mark who sat next to him, yet, "didn't really seek anyone out...I didn't really go out of my way this time, and I don't know why I didn't." Mary said that she felt there was little opportunity outside the breaks to socialise and that, "if you were only there for the actual class time, you wouldn't see how well people mixed outside of that, and within the class there wasn't a lot of opportunity to mix,

and Leigh...went home for lunch.” These comments were also echoed by Morgan who, in the following interview excerpt, explained that she did not get to know others students, including Leigh who was seated next to her:

Meeting people is the biggest thing they would have missed out on. For instance Andy didn't even, you know, it was the second week, third last day and he's looked up and gone, “Oh, you're in our class.” I don't really don't know what Sharon and Dan do for a living. I couldn't tell you, I have no idea, do you know what I mean? Or, for that matter, Leigh who sat next to me, I don't really know what she does. I know she works in office.

An interesting phenomenon of interaction that arose during all the post-course interviews with all students, except Mary and Wynn timer, was the difficulty students had in recalling the names of others. For example, Andy referred only to Brad, Boart and Dan by name, and to Coral, Leigh, Mark and Mary as, “that tutor sheila,” “those toffy nosed looking sheilas up there,” and, “that old baldy head old fella.” This lack of recall of other people's names is best exemplified in the following expert from Brad's interview, when asked to recall characteristics of Reggie:

Who's Reggie, I didn't even know who Reggie is, who's Reggie? Which one was Reggie...I just remember Borat here, Andy was there and Sharon over there, and Dan...of these girls that are sitting down here, up until today, if I'd have seen them out on the street, I wouldn't have known who the bloody hell they were...a couple of times I thought, “I wonder where he's come from?” Some of these down here, if they hadn't got up and done their presentation, I wouldn't even have known who they were.

Reported in Table L11 is the frequency and distribution of characteristics of socialisation described by participants. Visibility and interaction, that is, the visibility of others and the opportunity to talk and interact with them, was the most frequently reported characteristic. Three other important characteristics were: forming, that is the introduction of people and formation of group cohesion; mourning, that is saying goodbye and not expecting to meet others after the course; and movement, that is remaining in the same seat for the duration of the course. For many students, socialisation was characterised by only a few facets, and for some students, was characterised by only one.

These results may suggest that for most people, socialisation was characterised by a lack of social interaction amongst students through reduced visibility, room layout and opportunity. They may further suggest that for some people, socialisation was also characterised by lack of group processes including forming and mourning, and lack of movement that may have provided the opportunity to interact with others.

Teacher's Perspective of the Environmental Context

Sam explained that Tanya had trained and instructed her to teach the course in the manner it was delivered. It was the first time Sam had delivered the course, and felt that she could not change it because Tanya, "wasn't quite ready to let go that control." Sam said that she felt Tanya was watching her to ensure her teaching methods complied with Tanya's standards, and that as a result, she felt she did not have full control over the class. Sam described herself as being on probation, and that she probably would have more control the next time she ran the course. In the following interview excerpt, Sam recalled one previous occasion when she made a deviation from Tanya's teaching methods, and was reprimanded for doing so:

Table L11

Frequency Distribution of Socialisation Facets

Participant	Forming	Storming	Mourning	Movement	Interaction	Frequency	Distribution
Brad					1	1	1
Coral					5	5	1
Dan	2		2	1	1	6	4
Danni		1			2	3	2
Leigh					1	1	1
Mary	3		1		2	6	3
Morgan	2			2	2	6	3
Sam					2	2	1
Sharon	2		2			4	2
Wynnle			1	1		2	2
Frequency	9	1	6	4	16	36	
Distribution	4	1	4	3	8		

I didn't get into trouble, but you know, I was told, "No, we don't do it that way, they need to be participating and learning at the same time, so get them to do it, they've got the computers there. They can actually go through and learn as they're going. But get them to look up their training package." It's

like, “Yes, okay, rightey-oh.” So that’s how I did it this time. And a lot of them got lost.

Sam explained that a previous trainer had lodged a formal complaint with the government about the inexperience and lack of knowledge of the trainers. This had put the registered training organisation that Tanya had partnered with under scrutiny and led to a formal audit. As a result, Tanya’s partnership agreement also came under scrutiny. Sam explained that the experience had left Tanya, “paranoid” about how the course was delivered. Sam also explained that, because it was not her venue and the computers were provided, she felt she did not have complete control over their use. She mentioned that she felt she could not tell students to stop using the computers or to close the lid of their laptops because she had used the computer when she had previously completed the course.

Sam expressed a desire to change elements of the task environment. These elements were: extending the duration of the course; reconfiguring the physical layout to provide a centre space so that students could work collaboratively and thereby increase social interaction; removing computers from the classroom; spending more time on learning than assessments; using activities such as training games to, “break the ice,” create interest and improve concentration; increasing student movement in the classroom by getting students out of their chairs and walking around the room; using student’s existing knowledge through inductive learning; moving students outside of the classroom to conduct their presentations in real world situations; and increasing the variety of lesson types to maintain interest.

Sam described the structure of the course that allowed both upgrade and full qualification students to attend the one course, as being, “very much about economics, rather than learning.” In the following interview excerpt, she expressed a

desire to improve the sequencing of learning for people who were completing the full qualification, by conducting the upgrade component separately:

Because one of things is the newbies are getting confused because the upgrade subjects are at the beginning. One of those is assessment validation. Hey we know nothing about assessment yet. Let's wait until we know what assessment is, we've trialed our assessment.

Sam also explained that the course focused on assessments rather than learning, and recalled that on one occasion Tanya had entered the classroom and said to her, "Have they done their assessment?" She told Tanya that students still had their diagram to do the next day, and Tanya replied, "Oh no, no, you've got to get their assessment done, you know, it's got to be done within that time."

Sam said that in future, she would do more planning and preparation prior to the course. She suggested that when students first enrol in the course, the teacher should ask what industry they are from and obtain a copy of the relevant industry training package. She also said that in the future, she would give students small amounts of homework.

APPENDIX M: SAMPLE DETAILED ANALYSIS OF REPERTORY GRID

Eleven constructs were identified by Danni during the construction elicitation process. After elicitation, and before element attribution, Danni reviewed these constructs. She determined that three constructs were already covered by the remaining eight and were therefore discarded. The final grid is reported at Figure M1.

Construct Meaning

To understand the richness of meaning beyond the construct labels, and to reduce the potential for misinterpretation of the grid data, it is useful to reflect back on the meaning that Danni ascribed to these constructs during the dialogue discussion. The explicit and implied meanings that Danni ascribed to many constructs were rich and complex, and contained many overlapping facets.

Drawn Together—Separated

Danni described people she saw as approachable, attracted to others, and who interacted with and responded to others in an emotionally positive way. She described these people as Drawn Together. In the following interview excerpt, Danni described people who were Drawn Together also formed friendships:

Those two formed a friendship I thought. Personalities were drawn together between that dog and that person I think. More than that dog and me, and even that person and me. That person was drawn more to the dog than that person was drawn to me. Interaction, and body language and, yes. She interacted a lot with Adonis. Every time he come near her, she lit up and would respond to him. And her and I never had a conversation in our seven days. Never had a conversation. Don't know [why that was].

1	Lady	Adonis	Buddy	Reggie	Sharon	Dan	Andrea	Morgan	Mary	Danni	Borat	Leigh	Wynn	Mark	Coral	Andy	Wade	Brad	Sam	Alma	5
Drawn Together	2	1	1	5	3	1	1	2	3	2	1	4	1	4	1	3	3	5	2	2	Separated
Communicator	2	1	1	5	4	2	1	1	2	1	2	3	1	2	4	5	3	5	2	3	Loner
Easy Going	2	1	1	5	4	2	2	1	2	1	1	2	1	3	4	5	3	5	2	3	Serious
Immature	5	1	3	5	4	3	4	1	5	4	3	5	1	5	5	5	4	5	3	3	Mature
Warm	4	1	1	5	4	2	1	2	3	1	1	2	2	4	4	5	4	5	3	3	Cold
Guarded Closed	3	5	5	1	1	3	4	5	3	4	4	2	2	2	2	1	2	2	1	2	Open
Fun Happy-Go-Lucky	3	1	1	5	4	3	2	1	2	2	2	3	1	4	5	5	3	3	2	3	Not Flippant
Unstructured	4	1	2	5	4	3	3	3	4	4	3	4	2	4	4	5	4	4	2	3	Judgemental

Figure M1. Raw repertory grid for Danni.

This description contrasts with Separated which Danni used to describe two groups of people who were friendly, yet kept themselves separate from each other. The first group of people she saw as unapproachable, who did not socially interact with or approach others, and who did not seek out individual relationships. Danni described the second group of people as excluded and isolated by the first group. Danni considered social interaction unimportant to people she saw as Separated. Danni implied that saw the Drawn Together pole as positive and the Separated pole as negative.

Communicator—Loner

For Danni, people who were Communicators were seen as having a sense of humour, and who showed interest in interacting with others. In contrast, Danni described Loners at the implicit end of this construct, as people who avoided social interaction. As Danni explained:

I tried to interact with this person, but he wasn't really interested. Tried, had one conversation out here at the table and he would, kept refocusing back to other people. So I really didn't have a conversation with him either. Pretty much a loner.

Danni implied that she saw the Communicator pole as positive and the Loner pole as negative.

Easy Going—Serious

Danni described those people she saw as Easy Going as easy to communicate with, down-to-earth, and more open. This contrasts with those people she described as Serious as, “pretty straight and narrow...straight down the line...no nonsense,” and, “more serious.” Implied within Danni’s description of this construct is a casual, relaxed and spontaneous orientation towards the outside world. This contrasts with a, “no nonsense,” facet of Serious, which Danni implied was characterised by structured, practical, and intolerant of irrelevancies. Danni did not appear to imply that either pole is positive or negative.

Immature—Mature

Danni described Immature people not by referring their age, but rather by referring to their outlook and approach to the world. She described the difference between the two poles of this construct as, “not, like not in the younger, more, yes, just a more mature outlook on life”. Implicit within Danni’s description of this construct may be a facet that could be described as responsibility and predictability. The opposite could be described as spontaneous. Danni did not appear to imply that either pole is positive or negative.

Emotionally Warm—Cold

Danni identified this construct quickly, and without hesitation described people in clear, concise and simple binary terms as being either emotionally and socially cold or warm and said, “This one’s cold, this one’s warm.” Within Danni’s description may be the implied meaning that people who are emotionally and socially cold may be seen as critical and unapproachable, and that those people who

are emotionally and socially warm, may be seen as approachable and accepting.

Danni implied that she saw the Emotionally Warm pole as positive and the Cold pole as negative.

Guarded Closed—Open

Danni described people she saw as Guarded Closed as people who were less trusting of others, for whom others it takes a long time to get to know personally, who may outwardly appear happy, but who were seen to be concealing a facet of their true self. For Danni, Guarded Closed people were those with whom she would not foster friendships. The following extract from Danni's dialogue discussion may help reveal a clearer understanding of this construct:

Well, if I was having a party I wouldn't invite them [laugh]. I don't know, it's just something about their personalities I don't like. Something, this lady here's so over the top and happy and whatever, but there's still something about her underlying that I don't, haven't quite got. I don't know her well enough, but I wouldn't be seeing her as a friend. And this lady is just off the planet, not my sort of person. Er, this lady probably doesn't trust anybody. I think it would be pretty hard. I think she's probably been emotionally scarred this woman. She'd take a long time to let you into her trust circle, and this woman here, there's something about her that, on the surface she looks all happy, but I think underneath there's something there a bit more, I think, that I wouldn't feel that she'd ever let you come, get in to her real soul. And the same with this one. [These people are] guarded, guarded.

Danni emphasised that there was a difference between the Open pole of this construct, and the Open facet of the Easy Going—Serious construct, which she described as being easy to communicate with. Danni described people located at the

Open pole of this construct as people who were, “willing to expose the nerves, get them hurt. Whereas these people have probably done that already in the past, and now they’ve closed up.”

In her description of this construct, Danni implied a facet of trust and honesty:

He’s a bit of a dog, put him over here, he’s an old dog [laugh]. Oh, I don’t know, just a bit of a, you know, tries to be a bit of a man’s man I think, you know. Like a real extroverted, done everything, you know type of person. Claim to fame, I’ve done everything, if I haven’t done it, I probably think I have type of person. Now I’m an extrovert too, and Adonis is. Extrovert’s probably not a good way of describing it. Not true, you know? Like, not being real true about, like a larger than life, not necessarily can you believe everything he says. But the dog would be honest and open and I feel I would be honest and open.

Danni implied that she saw the Guarded Closed pole as positive and the Open pole as negative.

Fun Happy-go-Lucky—Not Flippant

For Danni, people who were Fun Happy-go-Lucky were silly, fun-loving and see life as, “a ball, it’s easy, the world is a nice place to be in.” Danni described the implicit pole of this construct as more serious and, “...not as flippant.” Implicit within Danni’s description of this construct appears to be a facet of Serious that may differ to the one she described when eliciting the construct, Easy Going—Serious. Within the Fun Happy-go-Lucky—Not Flippant construct Danni implied a facet of Serious that is earnest, sober, resolute, determined and critical by contrasting it with, “not as flippant.” This implies someone who may be seen as

frivolous, offhand, glib or dismissive. This description appears subtly different to the facet of Serious that she described earlier as being structured, practical, and intolerant of irrelevancies. Danni implied that she saw the Fun Happy-Go-Lucky pole of this construct as positive and the Not Flippant pole as negative.

Unstructured—Judgmental

Danni described people she saw as Judgmental as being task-oriented, focused, disciplined and, “very single minded.” This contrasts with the emergent pole of this construct that she described simply as, “a bit more unstructured.” Danni implied that she saw the Unstructured pole as negative and the Judgmental pole as positive.

Randomisation Results

Reported in Table M1 are the results of the randomisation test conducted on Danni’s grid. These results show that correlations of $r = 0.63$ or greater were observed with a frequency of approximately 5% ($p = 0.050$). Therefore, correlations of $r \geq 0.63$ and $r \leq -0.62$ in Danni’s grid can be considered statistically significant.

Construct Correlations

Reported in Table M2 are the results of the correlation analysis of constructs within Danni’s repertory grid. The strongest positive correlation is between Constructs 2 and 3, which suggests for Danni, those people she saw as easy to communicate with, down-to-earth and open were also likely to be seen as having a sense of humour, and as showing an interest in interacting with others.

All constructs, with the exception of Construct 4 and 6 share strong positive correlations with at least four other constructs. This contrasts with the strong negative correlations between Construct 6 and Constructs 2, 3, 5 and 7. This suggests that Danni may structure her construct space dichotomously. On one side

Table M1

Randomisation Results for Danni's Grid

Critical values	Upper value	Lower value
p ~ 0.001	0.95	-1.00
p ~ 0.010	0.83	-0.87
p ~ 0.025	0.72	-0.71
p ~ 0.050	0.63	-0.62
p ~ 0.100	0.52	-0.48
p ~ 0.150	0.40	-0.39

Note. All p-values are 1-tailed, corresponding to the lower and upper critical values.

of the dichotomy are those people who Danni saw as having a sense of humour, who were approachable and attracted to others, who showed an interest in interacting with others, were easy to communicate with, were down-to-earth, open, emotionally and socially warm, were unstructured in their orientation to the world, and who were fun-loving and silly. On the opposite side of the dichotomy were those people who Danni saw as unapproachable, who did not socially seek out relationships or interact with others, who were socially and emotionally cold, who were structured in their orientation to the world, were practical and intolerant of irrelevancies, were critical and less trusting of others, who may have concealed a facet of their true selves from others, and who were task oriented and disciplined.

Table M2

Construct Correlations for Danni's repertory grid

	1. Drawn Together	2. Communicator	3. Easy Going	4. Immature	5. Warm	6. Guarded Closed	7. Fun Happy-Go-Lucky	8. Unstructured
1. Drawn Together	1.00							
2. Communicator	0.67	1.00						
3. Easy Going	0.67	0.95	1.00					
4. Immature	0.61	0.62	0.65	1.00				
5. Warm	0.70	0.84	0.89	0.61	1.00			
6. Guarded Closed	-0.56	-0.75	-0.75	-0.51	-0.78	1.00		
7. Fun Happy-go-Lucky	0.52	0.84	0.87	0.74	0.79	-0.73	1.00	
8. Unstructured	0.68	0.70	0.70	0.83	0.70	-0.53	0.79	1.00

This leaves only Construct 4 unaccounted for in Danni's dichotomous construct space, which shares a strong positive correlation Constructs 3, 7 and 8. This suggests that for Danni, people she saw as not having a "mature outlook on life," and who implicitly lacked responsibility and predictability in their behaviour, were also likely to be seen as "a bit more unstructured," silly and fun-loving and who saw life as, "a ball, it's easy, the world is a nice place to be in."

Element Correlations

Reported in Table M3 are the results of the correlation analysis of elements within Danni's grid. The strongest positive correlation is between Andy and Sharon. This may suggest that within Danni's construct space, these two elements were strongly related and most like each other.

The pattern of positive correlations between the elements suggests a clustering of the way Danni saw the dogs and people. The largest cluster is comprised of the strong positive correlations between Andrea, Borat, Buddy, Dan and Danni. Another cluster is made up of the strong positive correlations between Adonis, Buddy and Morgan. A further cluster is formed by the strong positive correlations between Andy, Reggie and Sharon. A final cluster appears to include the strong positive correlations between Alma, Andy and Coral.

Adonis shares the strong negative correlations with the greatest number of elements: Andy, Brad, Sam, Sharon and Wade. Conversely, he shares a strong positive correlation with only two elements: Morgan and Buddy. This may suggest that within Danni's construct space, Adonis and Buddy were seen as being similar, and that for Danni, Adonis was most unlike Andy, Brad, Sam, Sharon and Wade.

Buddy shares strong positive correlations with the greatest number of other elements in the grid: Andrea, Borat, Danni and Morgan. Buddy also shares strong negative correlations with three elements: Reggie, Sharon and Andy. This may suggest that within Danni's construct space, Buddy shared a similarity with herself, Andrea, Borat and Morgan that was an inverse relationship that Buddy shared with Andy, Reggie and Sharon.

Table M3

Element Correlations for Danni's repertory grid

	Lady	Adonis	Buddy	Reggie	Sharon	Dan	Andrea	Morgan	Mary	Danni	Borat	Leigh	Wynnie	Mark	Coral	Andy	Wade	Brad	Sam	Alma
Lady	1.00																			
Adonis	-0.04	1.00																		
Buddy	0.36	0.87	1.00																	
Reggie	0.04	-1.00	-0.87	1.00																
Sharon	0.18	-0.94	-0.78	0.94	1.00															
Dan	0.62	0.34	0.58	-0.34	-0.09	1.00														
Andrea	0.57	0.55	0.86	-0.55	-0.42	0.79	1.00													
Morgan	0.09	0.86	0.76	-0.86	-0.85	0.27	0.47	1.00												
Mary	0.83	0.00	0.46	0.00	0.00	0.36	0.63	0.19	1.00											
Danni	0.60	0.47	0.79	-0.47	-0.43	0.66	0.89	0.57	0.76	1.00										
Borat	0.44	0.67	0.88	-0.67	-0.53	0.79	0.87	0.63	0.47	0.87	1.00									
Leigh	0.44	-0.40	0.01	0.40	0.30	0.11	0.27	-0.27	0.71	0.51	0.21	1.00								
Wynnie	0.40	0.49	0.45	-0.49	-0.39	0.32	0.27	0.78	0.26	0.37	0.40	-0.34	1.00							
Mark	0.65	-0.57	-0.23	0.57	0.50	0.09	0.10	-0.38	0.63	0.24	-0.18	0.65	-0.13	1.00						
Coral	0.48	-0.47	-0.23	0.47	0.71	0.56	0.14	-0.57	0.09	-0.06	0.03	0.12	-0.17	0.33	1.00					
Andy	0.23	-0.88	-0.71	0.88	0.99	0.03	-0.34	-0.81	0.00	-0.39	-0.45	0.23	-0.32	0.45	0.80	1.00				
Wade	0.67	-0.71	-0.38	0.71	0.76	0.07	-0.08	-0.43	0.57	0.04	-0.22	0.49	0.10	0.76	0.54	0.75	1.00			
Brad	-0.03	-0.78	-0.65	0.78	0.69	-0.62	-0.53	-0.69	0.11	-0.50	-0.68	0.30	-0.41	0.34	0.15	0.62	0.61	1.00		
Sam	0.57	-0.71	-0.44	0.71	0.73	-0.11	-0.22	-0.63	0.42	-0.22	-0.42	0.37	-0.16	0.73	0.53	0.71	0.87	0.72	1.00	
Alma	0.34	-0.65	-0.48	0.65	0.87	0.31	-0.12	-0.65	0.00	-0.27	-0.21	0.07	-0.15	0.29	0.93	0.93	0.65	0.40	0.60	1.00

Sharon shares a strong negative correlation with two dogs, Adonis and Buddy, however does not share a strong positive correlation with Lady. This may suggest that Danni viewed Sharon as the person who was most unlike both Adonis and Buddy.

Lady shares a strong positive correlation with only one element, Mary, and does not share a strong negative correlation with any element within the grid. This may suggest that for Danni, Mary and Lady were congruently located within her construct space, and that Mary was the only element which Lady shared any similarity. Danni shares a strong positive correlation with only one dog, Buddy. This suggests for Danni, Buddy was the dog whom she may saw as most like herself.

There is an absence of correlation between Mary and Adonis, Alma, Andy, Reggie and Sharon. This is the only occurrence of zero correlations in this grid and given that the construct ratings for Mary in the raw grid do not show a loading towards the midpoint, suggests that Danni may have seen Mary as being unique and different to these elements.

Cluster Analysis

Reported in Figure M2 are the results of the cluster analysis of elements for Danni's grid data. It shows two main groupings of elements, separated where the z-scores decrease, that divides the elements into two even groups of 10 each, separated between Sam and Leigh. This supports the construct correlations that indicate Danni may structure her construct space dichotomously, with all elements located on either side of the dichotomy. Adonis and Buddy are located in one cluster, and Lady is located in the other. This suggests that Danni may have viewed Adonis and Buddy as dichotomously opposite to Lady. Within each of these two main groupings are two smaller clusters of seven and three elements. Within the first grouping, Wynnie, Morgan, Adonis, Buddy, Borat, Andrea and Andy are clustered together, leaving Dan, Alma and Sam to form the second smaller cluster. Within the second grouping, Leigh, Mary, Lady, Mark, Wade, Sharon and Coral are clustered together, leaving Andy Reggie and Brad to form the second smaller cluster. This pattern of clustering of elements may suggest a dichotomous structure of Danni's construct space, which may also be influenced by another component, though to a lesser extent.

Reported at Figure M3 are the results of the cluster analysis of constructs for Danni's grid. It shows two distinct groups of constructs, separated where the z-scores decrease. Constructs 7, 2, 3 and 5 form one grouping, and Constructs 4 and 8

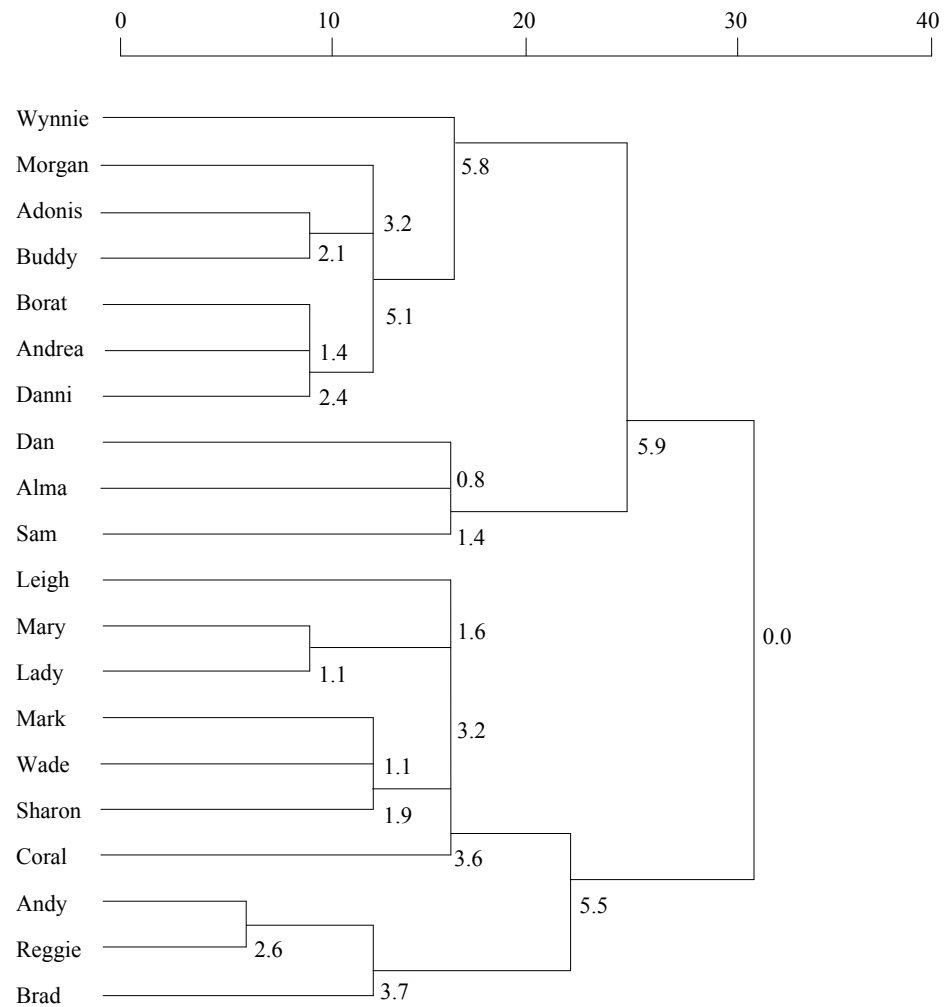

Figure M2. Cluster analysis of elements from Danni's repertory grid.

form a second grouping. Constructs 1 and 6 are not clustered with any other construct, and therefore appear unrelated to all other constructs. These constructs may operate separately in defining Danni's construct space. This pattern of clustering shares congruence with and therefore supports, the factor loadings and description of the two principal components.

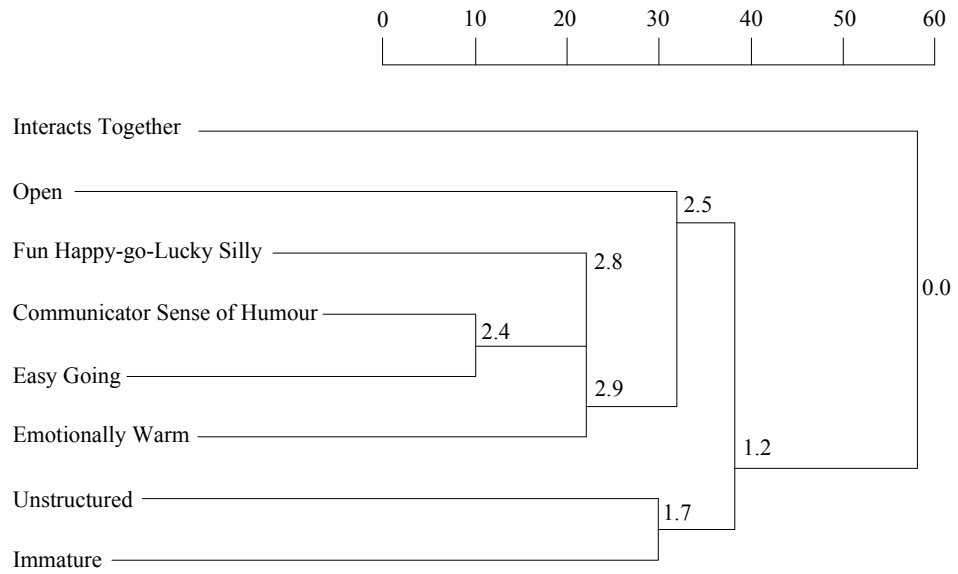

Figure M3. Cluster analysis of constructs from Danni's repertory grid.